

M&E SCHEDULE 2023



MECHANICAL AND ELECTRICAL DEPARTMENT SPECIFICATIONS 2023

BRIHANMUMBAI MUNICIPAL CORPORATION
DEPARTMENT- CHIEF ENGINEER (MECHANICAL & ELECTRICAL)

FAIR MARKET ELECTRICAL SCHEDULE

FME 2023

VOLUME- II- SPECIFICATIONS

**OFFICE OF:
THE CHIEF ENGINEER
(MECHANICAL AND ELECTRICAL)
Engineering Hub Building,
Dr. E. Mosses Road,
Worli Naka, Worli,
MUMBAI- 400 018.**

INDEX

GENERAL REQUIREMENTS

SP-ME-GR-1	SWITCHGEAR:	7
SP-ME-GR-2	WIRING:	7
SP-ME-GR-3	CONDUITS,PIPES AND DUCTS:.....	8
SP-ME-GR-4	LIGHTING SYSTEM AND POWER RECEPTACLES:.....	9
SP-ME-GR-5	LIGHTING FIXTURES WITH CONDENSER:	10
SP-ME-GR-6	CABLES:.....	12
SP-ME-GR-7	POLES AND POLE ACCESSORIES:	13
SP-ME-GR-8	PUMP SET AND PLUMBING:.....	13
SP-ME-GR-9	SERVICE CUPBOARDS:	14
SP-ME-GR-10	EARTHING:.....	14

TECHNICAL SPECIFICATION

SP-ME-TS-1	CUBICAL PANEL, PUMP PANEL AND DB.....	15
SP-ME-TS-2	APFC PANEL.....	19
SP-ME-GR-3	SWITCHGEAR:	21
SP-ME-TS-4	ELCB / RCCB	27
SP-ME-TS-5	JUNCTION BOX / ANGLE IRON FRAMEWORK.....	28
SP-ME-TS-6	CABLES:.....	30
SP-ME-TS-7	G.I. CABLE TRAY PERFORATED TYPE:	38
SP-ME-TS-8	G.I. CABLE TRAY LADDER TYPE :	40
SP-ME-TS-9	G.I. FLOOR TRUNKING / DUCT / RACEWAY:.....	42
SP-ME-TS-10	PVC TRUNKING:	44
SP-ME-TS-11	CABLE JOINTS	45
SP-ME-TS-12	MAIN / SUBMAIN WIRING AND POINT WIRING:	45
SP-ME-TS-13	POLES AND ACCESSORIES:.....	51
SP-ME-TS-14	SURFACE MOUNTING MONOBLOCK PUMP SETS:.....	57
SP-ME-TS-15	OPEN WELL SUBMERSIBLE PUMP SETS:	59
SP-ME-TS-16	JET PUMPS:	62
SP-ME-TS-17	SELF PRIMING PUMPS:	65
SP-ME-TS-18	SUBMERSIBLE PUMP SET (BORE WELL)	67
SP-ME-TS-19	FITTINGS AND FIXTURES:	71
SP-ME-TS-20	T-5 FIXTURES:	88
SP-ME-TS-20A	LED FIXTURES:.....	96

SP-ME-TS-21	CORROSION PROOF STREET LIGHT LUMANAIRE:	103
SP-ME-TS-22	ENERGY SAVER CORROSION PROOF LUMINAIRE:	104
SP-ME-TS-23	ENERGY SAVER BULKHEAD LUMINAIRE:.....	104
SP-ME-TS-24	ENERGY EFFICIENT STREET LIGHT	105
SP-ME-TS-25	RECESSED MOUNTED CFL LUMINAIRES - 36 WATT	105
SP-ME-TS-26	RECESSED MOUNTED CFL LUMINAIRES LOW WATTAGE	105
SP-ME-TS-27	ELECTRONIC BALLAST	106
SP-ME-TS-28	FAN'S ELECTRONIC REGULATOR	106
SP-ME-TS-29	FLUORESCENT TUBE :- 28 W – T 5 (4FT.)	106
SP-ME-TS-30	WIRE GUARD FOR MH/STREET LIGHT/ CFL FITTINGS	107
SP-ME-TS-31	DIESEL GENERATING SET	107
SP-ME-TS-32	AMF PANEL.....	111
SP-ME-TS-33	REMOVAL AND REFIXING OF ELECTRICAL ACCESSORIES.....	112
SP-ME-TS-34	PAINTING	112
SP-ME-TS-35	REPAIRS/REWINDING OF INDUCTION MOTORS/FANS/PUMPS	114
SP-ME-TS-36	REPAIRS & PAINTING TO STEEL FURNITURES	115
SP-ME-TS-37	EARTHING & LIGHTENING PROTECTION.....	121
SP-ME-TS-38	TESTING & INSPECTION EARTHING & LIGHT. PROTECTION	123
SP-ME-TS-39	SOLAR STREET LIGHTING SYSTEM (CFL).....	126
SP-ME-TS-40	SOLAR STREET LIGHTING SYSTEM (LED FIXTURES).....	127
	20WLED SOLAR STRT LITH SYSTEM WITH 5 YRS WARANTY.....	
SP-ME-TS-41	DOUBLE WALL CORRUGATED PIPES.....	132
SP-ME-TS-42	HIGHMAST	132
SP-ME-TS-43	GYMNASIUM EQUIPMENTS	140
SP-ME-TS-44	BOREWELL	153
SP-ME-TS-45	HANDPUMP	156
SP-ME-TS-46	SOLAR WATER HEATING SYSTEM:.....	157
SP-ME-TS-47	SPECIFICATION FOR THE PLAY APPARATUS	164
SP-ME-TS-48	EPABX	247
SP-ME-TS-49	SWITCHBOX POINT FOR COMPUTER, ETC	252
SP-ME-TS-50	PROVIDING AND FIXING OF CASING CAPPING LAYING	253
SP-ME-TS-51	PROVIDING AND FIXING OF PVC CONDUIT LAYING	254
SP-ME-TS-52	PUBLIC ADDRESS SYSTEM	255
SP-ME-TS-53	PROJECTOR	257

SP-ME-TS-54	CCTV ETC.....	259
SP-ME-TS-55	NETWORK ACCESSORIES	271
SP-ME-TS-56	INVERTER	294
SP-ME-TS-57	ELECTRONIC SIREN.....	295
SP-ME-TS-58	PRESSURE GAUGE	296
SP-ME-TS-59	GUN METAL VALVE.....	297
SP-ME-TS-60	APC SYSTEM FOR CONVENTIONAL WOOD PYRE.....	298
SP-ME-TS-61	CONVENTIONAL WOOD PYRE SYSTEM.....	303
SP-ME-TS-62	PNG GAS BASED CREMATOR EQUIPMENT	304
SP-ME-TS-63	AIR CONDITIONING WORK (HVAC).....	326
SP-ME-TS-64	FIRE FIGHTING SYSTEM.....	394
SP-ME-TS-65	FIRE ALARM SYSTEM	423
SP-ME-TS-66	SPECIFICATIONS FOR PIPE NATURAL GAS SYSTEM.....	449
SP-ME-TS-67	TECHNICAL SPECIFICATIONS.....	490
	(FOR LIFT AND ELECTRICAL WORK)	
SP-ME-TS-68	TECHNICAL SPECIFICATIONS.....	524
	(FOR Medical Gas pipeline and Modular Operation Theatre)	

(NOTE : - The images shown in specification from SP-ME-TS-1 to SP-ME-TS-68 are for reference only)

**TECHNICAL
SPECIFICATIONS
M&E**

TECHNICAL SPECIFICATIONS M&E

GENERAL REQUIREMENTS (G. R.)

SP-ME-GR-1 SWITCH GEAR:

- (i) All switch fuse units of 60/63 Amps. Capacity and above shall be enclosed in sheet steel box with HRC Fuses having breaking capacity of not less than 35 MVA at 440 Volts. The switch fuse units shall be provided with suitable size of cable end boxes wherever necessary.
- (ii) Unless otherwise specified all switch fuse units up to 30/32 Amps. Capacity shall be Cast Iron Clad type with rewirable fuses.
- (iii) Change over switches shall be Cast Iron Clad up to 30/32 Amps. and above 30/32 Amps. in sheet steel enclosure.
- (iv) Cubical panel complete with inter-connections shall be mounted on wall with angle iron frame in proper alignment. The panels which are mounted on floor shall be fixed on cement concrete foundation by providing 150 mm (6 inch) clearance at the bottom.

SP-ME-GR-2 WIRING:

- (i) All the wiring shall be done on the distribution system with the main and branch distribution boards at convenient physical and electrical load center.
- (ii) All runs of wiring shall be laid in such a manner that crossing is avoided.
- (iii) All runs of wiring and exact position of all points and switchgear shall be first marked on the buildings itself and approved by the Engineer.
- (iv) Single/multi-strand single/double sheathed PVC Wires shall be from fresh stock. Lights and fans shall be wired on a common circuit, including socket outlets.
- (v) As regards power circuits, in no case, there shall be more than 2(two) power points on each circuit.
- (vi) Each sub-circuit 'Power' or 'Lighting' shall be protected by a fuse
- (vii) Power outlet socket shall be provided with pilot indicating lamp and fuse unit.
- (viii) When conductors pass through walls and floors, the conductors shall be wired through rigid pipe PVC sleeves of suitable size permitting easy passing of the wires. The ends of sleeves shall be neatly fixed with PVC bushings.
- (ix) All ceiling fans shall be wired to ceiling rose through connector to which fan rod wires shall be connected and suspended from hooks or shackles with the insulators between hooks and suspended rods.
- (x) Canopies on top and bottom of suspension rod shall be effectively suspended and connected to fan motors respectively.
- (xi) Fittings with all types of luminaries shall be suspended with suspension rods, wherever specified, from the ceiling with special couplers fixed on to single teak wood blocks or suitable size G. I. Clamp. The suspension rods shall be screwed to

TECHNICAL SPECIFICATIONS M&E

the couplers and end of the pipe shall touch within coupler to maximum extend and shall in addition be secured by means of split pins. Two such suspension rods shall be provided for each fitting.

- (xii) Fittings with all types of luminaries shall be supplied complete with all the standard accessories and they shall be duly wired. Ceiling rose shall be of 3-plated terminal so as to terminate earthing wire.
- (xiii) All ceilings roses, brackets, pendants and accessories attached to walls or ceilings shall be mounted on PVC or teak wood block. Teak wood block shall be varnished. Block shall not be less than 25 mm. / 40 mm. deep. Screws shall be used for attaching fittings and accessories to their base blocks. The PVC/Teak wood round blocks shall be fixed with long length screw.
- (xiv) All the teak wood articles shall be given one coat of varnished shellac conforming to I.S. 347-1952 over an application on marketed articles. If no application has been made earlier, two coats of varnish shellac conforming to I.S. 347-1952 shall be given.
- (xv) Suitable size danger boards in MARATHI & ENGLISH shall be fixed at every service position & where supply voltage exceeds 230 volts.

SP-ME-GR-3 CONDUITS, PIPES AND DUCTS:

- (i) The contractor shall supply and install conduits, pipes and ducts as specified. All accessories, fittings required for making the installation complete including inspection tees and elbows, check nuts, male and female brass or galvanized steel bushings, male and female reducers and enlargers, wooden plugs, caps, square headed male plugs, nipples, gland sealing fittings, junction boxes, glands, gaskets and box covers, saddles and all steel supporting work shall be supplied by the contractors. Conduit fittings shall be of the same material as the conduits i.e. all fittings shall be metallic/PVC/G.I. as the case may be.
- (ii) Conduits or pipes shall run along walls, floors and ceilings, or on steel supports in accordance with relevant layout drawings. Exposed conduit shall be neatly run and evenly spaced with conduits parallel when in racks or in blanks. Conduits shall be run as directly and as possible along with generally indicated route between two points with a minimum length and width, minimum of crossing, bending and cutting but without creating interference with other installations.
- (iii) When one or more wires are carried through a conduit size shall be such that the total cross sectional area of the wires does not exceed 60% of the internal cross sectional area of the conduit.
- (iv) The Contractors shall be responsible for bonding of metal pipes or conduits in which wires have been installed to the main earthing system. The entire system of conduit after installation shall be tested for mechanical and electrical continuity throughout and permanently connected to earth by means of special approved type earthing clamp efficiently fastened to the conduit. Gas or water pipes shall not be used as an earth medium. In case of casing-n-capping wires shall be non-layer without any joint.

TECHNICAL SPECIFICATIONS M&E

Casing-n-capping shall have minimum joints.

- (v) Metallic conduits shall be filled bend as far as possible. All filled bends required in conduit run shall have uniform long radius sweeps, bent on a suitable power bender or with other approved bending tool. The radius of any conduit bend, measured from the center shall be not less than the bending radius listed for the particular conduit size in the following table under the column headed 'Recommended Minimum'.

Bending radius schedule

Size of conduit Metallic Conduit inside Radius of Bend

Nominal diameter in mm	Recommended Minimum mm	Allowable Minimum mm
20	195	195
25.4	255	255
31.8	320	320
38	385	385
51	510	450
63.5	635	510
76.2	765	610
88	890	690
101.6	1020	765

SP-ME-GR-4 LIGHTING SYSTEM AND POWER RECEPTACLES:

- (i) The Contractors shall supply all lighting switches, power receptacles, distribution boards and sub-distribution boards complete with switch fuses, junction boxes, pull boxes, terminal blocks, glands, conduits and accessories (elbows, tees, crosses, bends etc.), supporting and anchoring materials, to make the installation complete. The Contractor shall also supply all lighting fixtures complete with fluorescent tubes / incandescent lamps / sodium vapour lamps /mercury vapour lamps, and lighting cables. All materials, fittings and appliances used in the electrical installation shall conform to the I.S. Specifications.
- (ii) Wiring shall be colour coded so as to enable easy identification of phase, neutral and earth wire.
- (iii) Main and sub-distribution boards shall conform to the stipulations of IS 732 or as approved by the Engineer's at site. These shall be weatherproof and dust-proof.
- (iv) Receptacle and lighting fixtures shall be fed from different circuits.
- (v) All receptacles and switches to be installed in offices, control rooms and other

TECHNICAL SPECIFICATIONS M&E

decorative/finished area shall be flush mounted.

- (vi) All exposed metal parts of the plug, when the plug is in complete engagement with the socket outlet, shall be in effective electrical connection with the earthing pin.
- (vii) Conduits and fixtures shall be grounded properly by tinned copper wires by means of approved type grounding clamps efficiently fastened to the conduit pipe with earthing clips. To achieve perfect electrical continuity, the conduits shall be bounded effectively on either end of coupling and other points. Conduits shall be grounded at the ends adjacent to switch boards at which they originate or otherwise at the commencement of the run by a grounding conductor connected to an earth clip, clamp or gland in active electrical contact with the conduit.
- (viii) The contractor in the presence of the Engineer shall carry out installation tests as stipulated in IS-732 and other codes or practices before putting the installation in service

SP-ME-GR-5 LIGHTING FIXTURES WITH CONDENSER:

- (i) The lighting fixtures offered shall comply with the following requirements:

The fixtures shall be suitable for operation on a nominal supply of 240 Volts, Single Phase, 50 Hz A.C. with a voltage variation of + 6%.

All fixtures shall be designed for minimum glare. The finish of all parts of the fixtures shall be such that no bright spots are produced either by direct light source or by reflection.

All fixtures shall be designed for continuous operation under atmospheric conditions specified without reduction in lamp life, deterioration of material and internal wiring.

For multi-lamp fluorescent fittings, the circuit should be designed in such a manner as to reduce the stroboscopic effect to the minimum.

- (ii) Lighting fixture ballast shall be designed, manufactured and supplied in accordance with the relevant standard and shall function satisfactorily under site conditions specified. The ballast shall have a long service life and low power loss.

Ballast shall be mounted using self-locking, anti-vibration fixture without removing the fixture.

The ballast shall be of the inductive and heavy-duty type, copper wound, filled with polyester. The ballast shall be free from hum and protected from the atmosphere. Ballast which produce a humming sound shall be replaced free of cost by the contractor. HPMV Lamp ballast shall be provided with tapping.

For multi-lamp fittings, separate ballast shall be provided for each lamp.

- (iii) Lighting fixture starter shall be of the safety type i.e. if the lamp fails to ignite at the first start, no further starting must be possible without attending to the tube light. Starter shall have bi-metal electrodes and high mechanical strength. Starters shall be

TECHNICAL SPECIFICATIONS M&E

replaceable without disturbing the reflector or lamps and without the use of any tool. Starter shall have brass contacts and radio interference capacitor.

- (iv) Lighting fixture capacitors shall have constant value of capacitance and shall be connected across the supply of individual lamp circuits. Each capacitor shall be suitable for operation at 240 Volts (+ 6%) single phase, 50 Hz with a suitable value of capacitance so as to correct the power factor of its corresponding lamp circuit to the extent of 0.98 lag.

The capacitors shall be hermetically sealed preferably in a metal container to prevent seepage of impregnating material.

- (v) Lamp holders for fluorescent tubes shall be spring loaded, low contact resistance, bi-pin rotor type, resistant to wear and suitable for operation at the specified temperature, without deterioration in insulation value, contact resistance or lamp holding quality. Rotors shall hold the lamp in position under normal condition of shock and vibration. Lamp holders for incandescent and HPMV lamps shall be of GES type manufactured in accordance with relevant standard and designed to give long and satisfactory service.

- (vi) Lighting fixture reflectors shall generally be manufactured from sheet steel or aluminium of not less than 22 SWG/ 0.71mm or metalized plastic. Fixtures shall be readily removable from the housing for cleaning and maintenance without disturbing the lamp and without the use of tools. Fixtures shall be securely mounted to the housing by means of positive fastening devices of a captive type. For the lighting fixtures in category-I the gauge of the C.R.C.A. sheet shall be as per manufacturers design.

- (vii) Polystyrene egg box type louvers shall be provided whenever specified. Appropriate captive type fixing devices shall be incorporated for securing these.

- (viii) Each fixture shall be complete with a four way terminal block for the connection and looping of incoming and outgoing supply cables. Each terminal shall be able to accept two 6 sq. mm. solid aluminium conductors.

- (ix) Each lighting fixture shall be provided with grounding terminal suitable for connecting 2.5sq. mm. stranded tinned copper grounding conductor terminal.

- (x) On completion of manufacture, all surfaces of the fixtures shall be thoroughly cleaned and degreased. The fixture shall be free from scale, dust, sharp edges and burrs.

The enamel finish shall be as per standard, non-porous and free from blemishes, blisters and fading.

The surface shall be scratch resistant, and shall have no signs of cracking or flaking when bent through 90 degrees on a 12-mm.-diameter mandrel.

All light reflecting surfaces shall have optimum light reflecting co-efficient such as to ensure the overall light specified.

TECHNICAL SPECIFICATIONS M&E

All reflectors and louvers shall be finished to the standard as the fixture housing.

(xi) The following routine tests shall be conducted as per the relevant Indian Standards:

Each fixture shall be tested at 1500 Volts R.M.S. at 50 c/s for one minute and no flash over or breakdown shall occur between current carrying parts and ground.

Each fixture complete with its proper lamp/lamps shall operate satisfactorily at its normal voltage and frequency.

Each fixture shall be examined visually to ensure that it is complete in all respects and satisfactorily finished.

All luminaries provided with glass covers shall be subjected to thermal shockproof test. This test shall be conducted to ensure that the cover glass will withstand sudden variation in surface temperature due to rainfall or splashing water when the lighting fixture is fitted. The cover glass shall be heated in an oven to attain a steady temperature of 100⁰ C. and then plunged into cold water. No crack should develop.

SP-ME-GR-6 CABLES:

- (i) Cables shall be capable of satisfactorily withstanding, without damage, during transportation to site, installation at site, and operation under normal and short circuit conditions of the various systems to which the respective cables are connected, when operating under the climatic conditions prevailing at the site as indicated in these specifications.
- (ii) Cables shall be capable of giving satisfactory performance when laid in trays, trenches, conduit, and ducts and when directly buried in the ground.
- (iii) Cables shall be capable of operating satisfactorily under a power supply system voltage variation of + 6% and frequency variation of + 2%.
- (iv) Cables shall normally be laid under the following conditions
- In air-ambient temperature of 40⁰ C.
 - In ground-ground temperature of 3000 C.
 - Depth of laying in ground - 750 mm.
 - In conduits – space factor of not more than 60%.
- (v) PVC Insulated Cables shall be 1100 V grade heat resistant, fire retarding type.
- (vi) If shorter radius appears necessary, no bend shall be made until clearance and instructions have been received from the Engineer's Representative.
- (vii) Wherever groups of H.V. and L.V. cables are to be laid along the same route, suitable barriers to segregate these cables physically shall be introduced.
- (viii) Wherever cables crosses roads and water, oil, gas or sewage pipes or G.I. Pipes/corrugated, the cables shall be laid in reinforced spun concrete
- (ix) Pipes. For road crossings the pipe for the cable shall be buried at not less than 1-meter depth.

TECHNICAL SPECIFICATIONS M&E

- (x) The armour of the cable shall be bonded to the earthing system of the station.
- (xi) All new cables shall be megger tested before laying and after jointing is completed, all L.V. cables shall be megger tested and H.V. cables (3.3 KV to 11 KV) pressure tested before commissioning. The voltage for pressure testing shall as per Appendix 'F' of IS: 1255. 1100/650 Volts grade cables shall be tested by 1000 Volts megger.
- (xii) Cable cores shall be tested for:
 - Continuity
 - Absence of cross phasing
 - Insulation resistance to earth
 - Insulation resistance between conductors

Contractor shall furnish all testing kit and instruments required for field testing whenever asked by the site Engineer/Engineers representative

SP-ME-GR-7 POLE AND POLE ACCESSORIES:

Electric tubular Swedged poles shall be fabricated from steel tubular pipes except otherwise specified. The dimensions of poles shall be as per Indian Standard Specification. Suitable mounting brackets for installation of streetlight fittings shall be provided as specified.

SP-ME-GR-8 PUMP SET AND PLUMBING:

Pump set shall be properly aligned on ISMC base-frame. The foundation bolt shall be grouted in cement concrete foundation of 1:2:4 proportions or as recommended by the manufacturers. All the instruments such as ammeter, voltmeter, pressure gauges etc., shall be made available for testing the pump set. Plumbing shall be carried out using leveling instrument, neatly and systematically. Unnecessary bends shall be avoided to reduce the losses.

'C' class G.I. Pipe as per IS-1239 and accessories shall be provided. Alternatively wherever specified, flanged steel pipes shall be used.

TECHNICAL SPECIFICATIONS M&E

SP-ME-GR-9 SERVICE CUPBOARDS:

- (i) The switchgear distribution boards and KWH meters shall be mounted on a marine ply of best quality, thoroughly protected, both inside and outside with good insulating varnish conforming to I.S. Specifications. Planks of cupboard shall be 12 mm thick and 150/200 mm. wide, and back shall be of 20 mm. thickness. The frame for the cupboard shall be of 25x40 mm size. Top half portion of front door shall be covered with G.I. Wire Mesh of size 10 mm. x 10 mm. or suitable size available and of 20/22 SWG/0.91/0.7mm Wire.
- (ii) The cupboard shall be provided with twin or four panelled shutters 12 mm. thick with stainless steel hinges and locking arrangements, danger boards etc. The cupboards shall be securely fixed to the wall by means of coach screws or heavy-duty wire nails, wooden gutties etc. as directed by the site Engineer.
- (iii) Approximate openings for incoming and outgoing services in conduits or cables, earth protection pipes shall be kept insides of the cupboard
- (iv) Meter board wiring shall be properly clipped and identification marking for circuit shall be provided.
- (v) Adequate support of marine ply. Batten shall be provided for cupboards having length & height more than 1 mtr.

SP-ME-GR-10 EARTHING :

- (i) All the non-current carrying metal parts of electrical installation such as metal conduits, switch gear, distribution switch boards and all other parts of metal shall be bonded together and connected by means of two separate earth continuity conductor to earth electrode.
- (ii) The earth pin of socket outlets shall be effectively connected to earth.
- (iii) Each building and each pump-set shall have an independent earth electrode.
- (iv) Earth continuity conductors shall be of high conductivity. G.I. wire of cross sectional area not less than 10 gauge shall be used.
- (v) Protection against mechanical damage / corrosion shall be provided wherever necessary by carrying earth conductor in 'B' class G.I. Pipes of 12 mm. nominal dia. and 12 mm G.I. bend at one end or suitable size 'B' class G.I. Pipe & G.I. bend.
- (vi) Earthing conductor shall be so placed and connected so that it is not likely to be accidentally damaged or cut. It shall be fixed over its entire length by clamps, clips, saddles, and staples, which in no way will damage the conductor.
- (vii) Joints in earthing conductor shall not be normally permitted.
- (viii) The entire system of earthing shall be tested for mechanical and earth continuity.
- (ix) Supply and fixing earthing bare wire, G.I./Copper as instructed, to be laid along with cables or from panels to switch gear D.Bs / Equipments etc.

TECHNICAL SPECIFICATIONS M&E

SP-ME-TS-1 TECHNICAL SPECIFICATIONS FOR CUBICAL PANEL, PUMP PANEL AND EXTENDABLE DISTRIBUTION BOARD

1) SPECIFIC REQUIREMENT

Scope of this specification covers design, manufacture, testing at manufacturer's works, supply, packing, forwarding and delivery from place of storage/ manufacturer's works to erection site including transit insurance, unloading, storage at site, assembly, erection, testing, installation, commissioning and performance demonstration of following Low Voltage Switchgear. Each switch gear shall be complete with all fittings and accessories.

Cubical Panel

Pump Panel

- (i) Incomer shall be 63A TPN MCCB, Thermal magnetic type with O/L + S/C + E/F releases, 25kA -1 No.
- (ii) DOL Starter feeder (MPCB + Contactor + O/L relay) up to 7.5 HP motor X 2 Nos OR Star delta starter feeder (MPCB + Contactor (3nos) + O/L relay) 7.5 HP to 10 HP motor X 2 Nos
- (iii) Motor feeder shall have type 2 co-ordinations. Chart shall be provided for approval.
- (iv) Motor feeders shall be provided with ON / OFF indication lamps and Start, emergency stop push buttons.
- (v) Provision for LPBS (Local push button station) shall be made in pump panel.
- (vi) Incoming feeder shall be provided with digital Ammeter, Voltmeter, both with built in selector switch.
- (vii) Incoming feeder shall be provided with phase, ON, OFF & Trip indicating lamps.

Extendable distribution board - Please refer BOQ

It shall comprise of following;

- (i) Incomer TP MCCB (50 KA for 1 sec) – 1no.
- (ii) Rotary Operating Mechanism – 1 no.
- (iii) Shunt Release – 1no
- (iv) Trip Alarm Contact – 1 no.
- (v) TP MCCB's : 32-63 A & 80-100 A & 120-200 A (25 KA for 1 sec) – no. as per requirement maximum up to 8 nos.
- (vi) Copper Busbars with coloured heat shrinkable insulated sleeves.
- (vii) Suitable S. S. Enclosure
- (viii) Digital Ammeter & Voltmeter (0-500 V), both with selector switch, Push buttons & Phase indicating lamps protected by 2 A SPMCB etc

TECHNICAL SPECIFICATIONS M&E

Codes and Standards

The Equipment shall comply in all respects with the requirements of the enclosed preamble and IS codes listed in part I of specifications.

2) DESIGN AND PERFORMANCE REQUIREMENT

- (i) All Panels shall be indoor type, free standing/wall mounting, metal enclosed, degree of protection minimum **IP42** certified, free standing, single front, compartmentalized fabricated with 2mm CRCA sheet steel for all doors, partitions and covers and 2.5mm CRCA sheet steel for load bearing sections including all ACB feeders.
- (ii) Panel shall be modular type front operated with interlocking door arrangement totally enclosed dust and vermin proof for indoor type applications
- (iii) Gland Plate thickness shall be 3.0mm.
- (iv) All panels shall conform to FORM 3b enclosure as per IEC 60439: 2004, Part I
- (v) Each door & cover shall have adequate reinforcement of suitable ribs & stiffeners such that it will not tremble, when opened.
- (vi) Sheet metal components shall be pre-treated using the seven tank phosphating process consisting of de-greasing, acid picking, de-rusting, phosphating and passivation including repeated rinsing in between each process. On completion of passivation of the components they shall be preheated and then epoxy powder coated with Siemens grey RAL 7032 shade for exterior as well as interior and Glossy White shade for the gland plates (Inside the panel) and component mounting plate. Thickness of all painting shall be minimum 80 microns.
- (vii) Clearance between the terminals of switches /fuses and panel doors shall allow convenient access for maintenance.
- (viii) Neoprene rubber gasket shall be used for all the door units and covers to render panel effectively dust proof. H. R. C. fuse shall be mounting type Bakelite base. Switches shall be front operated with interlocking arrangement to door. Switches shall be quick make and break type with spring-loaded contacts. Separate connector/ terminal block of appropriate size and ways shall be provided for cable connections.
- (ix) Incoming feeder shall be provided with flush type Ammeter / Voltmeter. Ammeter & voltmeter shall be provided with ASS (Ammeter selector switch) & VSS (Voltmeter selector switch). Meters shall be with zero adjustment.
- (x) Separate metering compartment shall be provided for all analogue / digital meters like multi function meter, voltmeter, ammeter, indication lamp etc. All wiring & MCB / MPCB shall be mounted in metering compartment such that meter maintenance can independent of the power compartments.
- (xi) All the welded and rough areas of the panel and steel structure shall be smoothened and made free from burrs, scales, grease and treated by chemical

TECHNICAL SPECIFICATIONS M&E

degreasing, pickling and phosphate coating. It shall be coated with anti-rusting priming coat. The panel shall then be painted internally and externally with one coat of primer and two coats of stove enamel paint one after the other complete with proper rubbing and smoothing etc. The paint shall be two tone paint, gloss or semi-mat finish.

3) BUS BARS

- (i) 1.1.1 All bus-bars shall be electrolytic grade Tinned Copper material only. Bidder shall specify the purity and conductivity of the bus bar along with the Bid.
- (ii) The current carrying capacity shall be as per I.S.standard.
- (iii) Bus bar shall be suitable to withstand short circuit current of 50 KA for one second. The tinned copper bus bar strip shall be drilled for connections and the current density of this strip shall be of 1.2 Amp/sq. mm. for phases and 0.8 Amp/sq. mm. for neutrals & complete with insulators.
- (iv) Bus bar shall be suitably insulated with insulating tapes of Red, Yellow, Blue and Black colour (Black for Neutral)
- (v) Bus bar supports shall be **SMC** type only irrespective of bus bar size. The span between the two insulators shall be as per the approved type test report for short time rating. Joint positions and insulators shall be properly adjusted so that they don't interfere.
- (vi) Bus bar bending shall be carried out on appropriate machines designated for the same rather than doing manually and avoid 90 deg. bending of cold bus.

4) EARTHING

- (i) Earth bus bars of Copper material shall be run all along the panel, extended out at both ends and properly supported to withstand stresses induced by the momentary short circuit current of value equal to the momentary short circuit rating of the associated switchboard/ panel.
- (ii) Earthing bus-bar shall be terminated at both ends of the switchgear to suit the connections to Purchaser's earthing conductor.
- (iii) All doors and detachable components inside the feeder are required to be earthed individually with green (with yellow band) colour PVC insulated multi stranded copper conductor wire of size 4 sq.mm and are to be looped & connected to horizontal earth bus.
- (iv) Door/ cover earthing shall be done with flexible tinned copper braid / insulated copper wire. Panel earth bus shall be sized considering symmetrical fault level of each panel.
- (v) Earthing bus shall be run continuously in panel drawn out suitably considering respective cable entry.
- (vi) Separate copper earth bus shall be provided at each cable alley for all the panels for connecting earth core of single phase outgoing cables, if required.

TECHNICAL SPECIFICATIONS M&E

(vii) Earth Bus bar shall be extended outside the switchboard at the both the ends.

5) CONTROL WIRING

- (i) All panel Control wiring shall be done by 1.1kV grade FRLS PVC insulated multi-stranded copper wire. CT circuit wiring shall be done with minimum 2.5 Sq.mm size wire of above specification. Control and Potential circuits shall be wired with minimum 1.5 sq. mm size wires of above specifications. Wires shall be grey coloured with suitable crimp able copper lugs. CT's & PT's wiring shall be colour coded for multi-phase identifications (R-Y-B-N).
- (ii) Each control wire shall be with identification ferrule of Terminal No., component designation and cross ferruling on both sides.
- (iii) Panel wiring & cabling shall be cross ferruled. Ferrules shall be etched & painted type. **'Printed' ferrules are not acceptable.**

6) TERMINALS

- (i) Isolating link type terminal with shorting facility shall be provided for CT connections & Clip on type terminals shall be provided for PT connections & other control circuit wiring.
- (ii) 20% extra terminals shall be provided for power as well as control for Purchaser's use in each feeder

7) CABLE END BOXES:

- (i) Providing cable end boxes suitable for PVC insulated armoured cables with Aluminium/Copper conductor. The boxes shall be fabricated from M.S. sheet of 14/16 SWG, 2.0 /1.6 sq.mm & shall be pre-treated with anti corrosive paint and powder coated with steel grey paint. The holes shall be suitable as per size of incoming/outgoing cables to the respective switchgear without keeping any gap between the two.
- (ii) A rubber gasket of suitable thickness shall be provided between the switchgear and cable end box. The mounting shall be done with cadmium plated Nut bolts of suitable sizes.



Cubical Panel



Pump Panel



DB

TECHNICAL SPECIFICATIONS M&E

SP-ME-TS-2 APFC Panel

Scope of this specification covers design, manufacture, testing at manufacturer's works, supply, packing, forwarding and delivery from place of storage/ manufacturer's works to erection site including transit insurance, unloading, storage at site, assembly, erection, testing, installation, commissioning and performance demonstration of the following equipment with associated accessories shall be supplied.

APFC panel shall have following specifications

Supply	3phase, 4wire
Rated voltage	415 V
Rated frequency	50 Hz.
Permissible overvoltage	1.1 Vn
Permissible over current:	1.5 In
Temperature category:	50 deg C (Design Ambient – 45 deg C)

Constructional of panel shall be as cubical panel.

Nameplates, rating plates and label for caution notice (danger board) shall be provided with proper description and details. External and internal white labels shall be engraved and filled with black colour.

The power capacitor is to maintain the power factor of the installation to predetermined value. & to reduce the power consumption and safeguard the distribution cables. The power capacitor shall be conforming to IS 2834-1981 and suitable to work in tropical conditions and for 415/440 Volts, 3 phase, 50 cycles A.C. supply. The capacitor shall be provided with terminal cover and internal fuses and discharge resistors. The capacitors shall be panel mounting / floor / walls. The capacitor shall be hermetically sealed. The capacitor shall be installed firmly to make the same immovable. The capacitor shall be properly earthed at the earthing terminal to avoid accidental leakage of charge. There shall be a clearance of at least 75mm all sides for every capacitor unit to ensure cooling and thermal stability. The insulation shall be of APP. Capacitors shall be installed in separate compartments and shall be provided with isolator and HRC fuses of appropriate capacity. The capacitor shall have a guarantee of at least 1(one) years and there should not be any reduction in output or fall in current during this guarantee period.

TECHNICAL SPECIFICATIONS M&E

1) APFC Panel shall include ‘

- (i) Incomer TP MCCB Thermal magnetic type O/L+S/C+E/F releases (25 KA for 1 sec) – 1no. -- L&T / MG / Siemens / C&S / CG makes
- (ii) APFC relay – 4/6/8 stage - 1 no. -- L&T / CG
- (iii) Three pole Power contactor as per no. of APFC relay stages -- L&T / MG / Siemens / C&S / CG
- (iv) All-Poly-Propylene type heavy duty Power Capacitors -- EPCOS / SHRIM / MADHAV
- (v) Current Transformers' set
- (vi) Suitable S. S. Enclosure
- (vii) Suitable accessories like phase indicating lamps, gasket, locks etc.

Panel wiring & control wiring shall be done with proper tagging & naming for identification, & by following the colour codes

2) Capacitor

The capacitors shall have Low Dielectric Loss of ≤ 0.5 W/ kVAR.

Capacitors shall be 480V rated, All Poly Propylene (APP) type.

The power capacitor shall be conforming to IS 2834-1981 and suitable to work in tropical conditions and for 415/440 Volts, 3 phase, 50 cycles A.C. supply. The capacitor shall be provided with terminal cover and internal fuses and discharge resistors. The capacitors shall be panel mounting / floor / walls. The capacitor shall be hermetically sealed.

The capacitor shall be installed firmly to make the same immovable. The capacitor shall be properly earthed at the earthing terminal to avoid accidental leakage of charge. There shall be a clearance of at least 75mm all sides for every capacitor unit to ensure cooling and thermal stability. The insulation shall be of APP.

Capacitor shall be installed in separate compartments and shall be provided with isolator and HRC fuses of appropriate capacity. The capacitor shall have a guarantee of at least 1(one) years and there should not be any reduction in output or fall in current during this guarantee period.



APFC Panel

SP-ME-TS-3 SWITCHGEAR

1) Switch Fuse Unit (with rewirable fuse):-

Supply, Installation, handling, testing and commissioning of the SFU with rewirable fuses (porcelain fuse unit) rating up to 32 Amps compliance to IEC 60947 Part 1 & 3 / IS 13947 part 1 & 3 to be enclosed in CRCA Sheet steel 18/20 SWG standard with powder coated, rust protected with PVC insulated cu wires for interconnection, bus bar, earthing terminal, and all other accessories to complete the work. SFU shall be wall/column mounted. MS angle iron frame to mount the unit shall be charged extra. Enclosure shall be weather proof.

SFU shall be provided with suitable size of cable end box wherever necessary.

2) Switch Fuse Unit (with HRC fuse):-

Supply, Installation, handling, testing and commissioning of the following rating SFU with HRC Fuses (Din type) with rupturing capacity 80kA as per IEC 60947 Part 1 & 3 / IS 13947 part 1 & 3 to be enclosed in CRCA Sheet steel 18/20 SWG standard with powder coated, rust protected with PVC insulated cu wires for interconnection, bus bar, earthing terminal, and all other accessories to complete the work. SFU shall be wall/column mounted. MS angle iron frame to mount the unit shall be charged extra. Enclosure shall be weather proof.

SFU shall be provided with suitable size of cable end box wherever necessary.

3) Changeover Switches:-

Supply, Installation, handling, testing and commissioning of the following rating on load changeover switches as per IEC 60947 Part 1 & 3 / IS 13947 part 1 & 3 to be enclosed in CRCA Sheet steel 18/20 SWG standard with powder coated, rust protected with PVC insulated cu wires for interconnection, bus bar, earthing terminal, and all other accessories to complete the work. Changeover switches shall be wall/column mounted. MS angle iron frame to mount the unit shall be charged extra. Enclosure shall be weather proof.

4) Isolator Switches

Supply, Installation, handling, testing and commissioning of the following rating Isolator switches as per IEC 60947 Part 1 & 3 / IS 13947 part 1 & 3 to be enclosed in CRCA Sheet steel 18/20 SWG standard with powder coated, rust protected with PVC insulated cu wires for interconnection, bus bar, earthing terminal, and all other accessories to complete the work. Isolator switches shall be wall/column mounted. MS angle iron frame to mount the changeover switch shall be charged extra. Enclosure shall be weather proof.

5) Cubical Panel

Cubical Panel shall be fabricated from CRCA sheet steel SWG 14 with powder coated, rust protected, provision earthing terminal connection, undrilled gland plate. Wall / column mounted panels shall be provided with angle iron frame. Panel which is floor mounted shall be free standing, compartmentalized, expandable on floor with base frame of ISMC 100 or

TECHNICAL SPECIFICATIONS M&E

as per load requirement. Enclosure shall be IP 52 for indoor and IP 55 with weatherproof canopy for outdoor application.

Cubical panel complete shall be with inter-connections, shall be mounted on wall with angle iron frame in proper alignment. The panels which are mounted on floor, shall be fixed on cement concrete foundation by providing 150 mm (6 inch) clearance at the bottom

Cubical panel shall be fabricated with depth of size 300 mm, 500 mm, 750 mm or as per site requirement.

6) MCCB

- (i) MCCBs shall be thermal magnetic type with overload, short circuit & earth fault releases. The E/F protection shall be provided with CBCT, earth fault leakage relay & shunt trip coil.
- (ii) All the MCCBs shall be of current limiting type and shall provide a cut off in 4 to 8 mSec for prospective currents during faults.
- (iii) MCCBs shall have ON and OFF indication lamps & trip position indication.
- (iv) All MCCBs shall be provided with rotary handle with door interlock feature.

The MCCB should be current limiting type with trip time of less than 10 msec under short circuit conditions. The MCCB should be either 3 or 4 poles as specified in BOQ. MCCB shall comply with the requirements of the relevant standards IS13947 – Part 2/IEC 60947-2 and should have test certificates for Breaking capacities from independent test authorities CPRI / ERDA or any accredited international lab.

MCCB shall comprise of Quick Make -break switching mechanism, arc extinguishing device and the tripping unit shall be contained in a compact, high strength, heat resistant, flame retardant, insulating moulded case with high withstand capability against thermal and mechanical stresses

The breaking capacity of MCCB shall be as specified in the schedule of quantities. The rated service breaking capacity (Ics) should be equal to rated ultimate breaking capacities (Icu). MCCBs for motor application should be selected in line with Type-2 Co-ordination as per IEC-60947-2, 1989/IS 13947-2. The breaker as supplied with ROM should meet IP54 degree of protection. All breakers shall be withstand for 2.5 kV voltage level between phase and earth for 1 second.

7) Current Limiting & Coordination

The MCCB shall employ maintenance free minimum let-through energies and capable of achieving discrimination up to the full short circuit capacity of the downstream MCCB. The manufacturer shall provide both the discrimination tables and let-through energy curves for all.

8) Protection Functions

MCCBs with ratings up to 63 A shall be equipped with Thermal-magnetic (adjustable thermal for overload and fixed magnetic for short-circuit protection) trip units

TECHNICAL SPECIFICATIONS M&E

Microprocessor MCCBs with ratings 150A above shall be equipped with microprocessor based trip units.

Microprocessor and thermal-magnetic trip units shall be adjustable and it shall be possible to fit lead seals to prevent unauthorised access to the settings

Microprocessor trip units shall comply with Annexure F of IEC 60947-2 standard (measurement of rms current values, electromagnetic compatibility, etc.)

Protection settings shall apply to all poles of circuit breaker.

All Microprocessor components shall withstand temperatures up to 125 °C

9) Interlocking

Moulded, case circuit breakers shall be provided with the following interlocking devices for interlocking the door of a switch board.

Handle interlock to prevent unnecessary manipulations of the breaker.

Door interlock to prevent the door being opened when the breaker is in ON position.

Defeat-interlocking device to open the door even if the breaker is in ON position.

The MCCB shall be current limiting type and comprise of quick make – Break switching mechanism. MCCBs shall be capable of defined variable overload adjustment. All MCCBs rated 100 Amps and above shall have adjustable over load & short circuit pick-up both in Thermal magnetic and Microprocessor Trip Units.

All MCCB with microprocessor based release unit, the protection shall be adjustable Overload, Short circuit and earth fault protection with time delay.

The trip command shall override all other commands.

10) MPCB

IMPCB shall be with 'relay function' (viz. fault cleared by MPCB whereas Overload cleared by contactor) and with contactor.

The features of Overload, short circuit and single phasing prevention shall be ensured.

MPCBs shall not have external/add-on 'limiter'. The limiter shall be integral/inbuilt part of MPCB. Short-circuit breaking capacity of MPCB shall be min. 10kA even without 'limiter'.

MPCB shall be complete with all desired accessories such as auxiliary contacts (min. 4); Alarm contacts and shunt trip coil, etc to meet the requirements as per interlocking & operational logic.

MPCB shall be suitable for motor protection (not just feeder protection) and suitably derated for temperature and arrangement in panels.

11) Starter

- (i) Supply, Installation, handling, testing and commissioning of the starter DOL / Star delta compliance to IEC 60947 Part 4/ IS 13947 part-4 to be enclosed in CRCA Sheet steel 18/20 SWG standard with powder coated, rust protected with PVC

TECHNICAL SPECIFICATIONS M&E

insulated cu wires for interconnection, bus bar, earthing terminal, and all other accessories to complete the work. Starter shall be wall/column mounted. MS angle iron frame to mount the unit shall be charged extra. Enclosure shall be weather proof.

- (ii) All motor feeders shall be type-2 co-ordinated as per IS-13947, part-4 with MPCB + contactor (AC3) +overload relay as applicable.
- (iii) Overload relay shall have adjustable tripping characteristics (i.e. class10, 20 & 30), built in single phasing protection feature and with feature to select Manual/Self reset at site.
- (iv) All motors of rating 0.5HP to 5HP shall be provided with DOL starter & motor above 5 HP shall be provided with star delta starter.
- (v) Motors <0.5kW will be single phase. Motors of rating 0.5kW and above will be three phase.
- (vi) Starter shall be provided with ON / OFF indication lamps and Start, emergency stop push buttons.
- (vii) The connection in the DOL starter shall be made through solder/crimping type lugs only
- (viii) The Star Delta starter shall be installed and commissioned by inter connection with switchgear and motor by PVC insulated copper flexible wire in PVC flexible conduit complete with gland etc. The rate for the same is included in cost of starter.
- (ix) Cost of angle iron frame for installation of starter is not included in starter rate.

12) Bus Bar Chamber

- (i) Fabricating, supplying, installing, testing and commissioning of bus bar chamber by using CRCA Sheet Steel 16 SWG and 25 x 25 x 3 mm. size angle iron frame work. It shall be erected on separate angle iron frame work. The cost is inclusive of interconnections with incoming and outgoing connections with sleeves of suitable size and PVC insulated copper wires up to 32 A and rest paid separately. The connection shall be made in lugs and connected to bus bar with Brass nut bolts and washers. The bus bar chamber shall be provided with tinned copper bus bar strip with PVC color sleeve/tape Red, Yellow, Blue & Black.
- (ii) The length of bus bar strip and chamber shall depend on number of outgoing switches. The Distance between each bus bar strip shall as per IE rules & also same clearance shall be provided on all sides.
- (iii) Mode of measurement of Bus bar: The length of the bus-bar shall be considered. Cost of Angle iron frame for installation of Bus bar is not included in Bus-bar item, same shall be paid separately.

13) Distribution Boards: (With Incomer & outgoing MCB).

- (i) Supply & Installation of distribution board of various sizes on wall/ Column, with required hardware & fasteners. Distribution boards with front operated double metal door, IP protection shall be IP 43/54 as per requirement, with DP/FP MCB, 10kA, 'C'

TECHNICAL SPECIFICATIONS M&E

curve for incoming and outgoing circuits of appropriate rating mounted on DIN rail and enclosed in slotted lid type boards with PVC insulated wires of copper conductor for interconnection. The board shall be mounted on angle iron frame with anchor fastener grouted in the wall as per specification. Distribution board width shall be limited to 600mm and mounting arrangement of MCBs shall be horizontal. All the DBs are inclusive of MCB, PVC insulated copper wires and sleeves / PVC flexible pipe, terminal connectors, earth bus, neutral bus, undrilled gland plate and earth terminals (2nos.). Civil work like grouting on wall for DB supports, making cut out for cable or conduit entry in slab/ ceiling etc., are included in the scope. Charges for M.S. angle iron frame are not included in the rate of DB. The SP, DP, TP, FP MCB shall be as per I.S.- 8826, 8828 & 13032 respectively.

- (ii) Inter connection charges are included in cost of distribution board up to 32A and rest paid separately.
- (iii) Incomer shall be provided with MCB + ELCB (30mA) as per rating and pole requirement.

14) Vertical DB:

- (i) Technical specifications shall be referred as per distribution board specifications.
- (ii) The vertical distribution board shall be three phase and neutral, sheet steel, powder coated double door type. One cover (door) shall be screwed for incoming and outgoing MCB's and one as cover for protection of complete DB. DB shall be fitted with colour coated bus bar, neutral link, earth bar and DIN rail etc (Complete pre-wired DB). The TP & SP MCB's can be used for outgoing circuit as per the requirement of site.

15) Mounting Arrangement

Supply, installation, testing and commissioning of M.V. switchgear mounted on M.S. Angle iron frame of specified size, properly grouted in wall/floor in approved manner at service/distribution position. The switchgear skeleton panel shall have:

- (i) The metal clad, T. P. / T. P. N. switch fuse units, Bus bar, distribution boards, starters, etc. shall be mounted vertically on M.S. frame of suitable sizes.
- (ii) The M.S. frame i.e. Angle Iron frame shall be fabricated from M. S. angles and M.S. flat as specified. The M.S. Frame shall be rigidly fixed to the wall by anchor fastener.
- (iii) The switchgear shall be fixed on M.S. Frame with suitable size nut and bolt etc. / M 10 (10 mm. dia.) x 40 mm. long G.I. nuts, bolts and washers. The mounting height shall not be less than 1200 mm. from the floor.
- (iv) Before fixing, the M.S. Frame shall be painted with red oxide paint. After grouting, the surface shall be finished nicely and frame shall be painted with two coats of synthetic enamel paint of Grey shade.

TECHNICAL SPECIFICATIONS M&E

- (v) After installation of switches, starters, bus bar, D. B.'s, all nuts and bolts shall be thoroughly greased and tightened properly.
- (vi) Inter connections shall be made with PVC insulated flexible copper wires in adequate size PVC flexible pipe with PVC glands. Inter connection charges are included in cost of switchgear up to 32 A and rest paid separately.
- (vii) Charges for marine plywood and M.S. angle iron frame are not included in the rate of switchgear.
- (viii) Support arrangement shall be get approved from concern site engineer before installation.



SwitchGear

TECHNICAL SPECIFICATIONS M&E

SP-ME-TS-4 ELCB / RCCB (with 30mA, 100mA as well as 300mA sensitivity)

The purpose of providing earth leakage circuit breaker is to isolate any portion of circuit instantaneously and to provide protection against electrocution risks and fires caused by earth leakage faults.

- (i) Under Indian electricity rules [Rules 61(A), 71(1), 73(1)], installation of an RCCB/ELCB is mandatory in all installations of 5kW and above, in all luminous tube sign and X-ray installations. The bureau of Indian standards recommends that RCCBs installed at construction sites, temporary installations, and agriculture and horticulture premises, limit the residual current to 30mA.
- (ii) The enclosure of Earth Leakage Circuit Breaker (ELCB) shall be molded from high quality insulating material which shall be fire retardant, anti-tracking, non hygroscopic and impact resistant. It shall withstand high temperature. The ELCB shall be capable of switching off the circuit within 30 millisecond (0.03 second) in case of fault.
- (iii) The mechanism shall be trip free ensuring that the ELCB cannot be re-closed / reset if the earth leakage / fault persists. The ELCB shall have repeat accuracy of less than 5% of the operating current. The unit shall be capable of withstanding starting inrush - current of motors up to 4/8 times the rated current. The operational life of the unit shall be over 20,000 operations with earthing terminal screw. The unit shall have a test push button to check the correct operation of the unit. The unit shall be 2 pole or 4 pole conforming to IS: 12640 and suitable for 16/25/40/63 Amp. E. L. C. B. shall be interconnected with suitable size copper wire meter leads. Charges for meter leads are not included in the cost of ELCB. Interconnection charges are included in the cost of ELCB. The charges of angle iron frame are not included in the cost of ELCB.
- (iv) The sensitivity of ELCB shall be 30mA, 100mA or 300mA as specified / required



ELCB



RCCB

SP-ME-TS-5 JUNCTION BOX / ANGLE IRON FRAMEWORK

This specification covers design, manufacture, supply, packing, forwarding and delivery from place of storage/ manufacturer's works to erection site including transit insurance, unloading, storage at site, testing, installation & commissioning of following

1) G.I. Junction Boxes:

Junction boxes made out of 16 / 18 SWG / 1.62 / 1.21mm G.I. sheet with full cover and complete with screw type locking arrangement. The boxes shall have suitable number of knockouts for incoming and outgoing cables. Incoming and outgoing cables shall be terminated with proper connection to this box with suitable glands and 10A heavy-duty connector for termination of wires/cables. Cost of connector is included in the cost of junction box. Glands are not included in the cost of junction box.

2) SMC Junction Box:

The junction box shall be made out of insulating materials such as Sheet Moulding Compound (SMC), ideal for outdoor use. Junction box shall have one piece moulded SMC base and SMC removable type cover or top/side hinged cover as per the requirement of site. Colour of SMC junction box shall be off-white or as approved by site engineer. According to the size of the junction box its thickness shall be 1.5 to 2.5 mm.

3) G. I. box for plugs and switches:

The specifications of G. I. Box shall remain same as G. I. Junction Box for providing:

- (i) 5A SP switch
- (ii) 15A SP switch.
- (iii) 5A SP switch & 5A three pin socket.
- (iv) 15A SP switch & 15A three pin socket.
- (v) 15A SP switch with 5/15A combined. Three pin socket with indicating lamp with 15A fuse with connector in box.
- (vi) 15A SP SW & 15A Three pin socket and 5A SP SW & 5A Three pin socket with indicating lamp & fuses with heavy duty connector in box.

4) Angle iron frame work:

M.S. angle iron framework shall be fabricated for fixing switchgear, as specified. M.S. angle iron framework shall be welded properly. Depending upon size of framework for switchgear, M.S. flats of the same size & thickness as that of M.S. Angle should be welded vertically or horizontally. For bigger size framework, angle iron legs duly welded at four corners shall be grouted in the wall with cement concrete of proper mix.

TECHNICAL SPECIFICATIONS M&E

For the smaller size framework of 30x30 x 3 mm. Angle & M.S. flat 25 x 3 mm. shall be welded to the Angle frame. The frame shall be grouted in the wall. M.S. Angle iron framework shall be painted with one coat Red Oxide and two coats of grey enamel paint in approved manner. The angle iron frame shall be provided with earth terminal for proper earthing



Junction Box

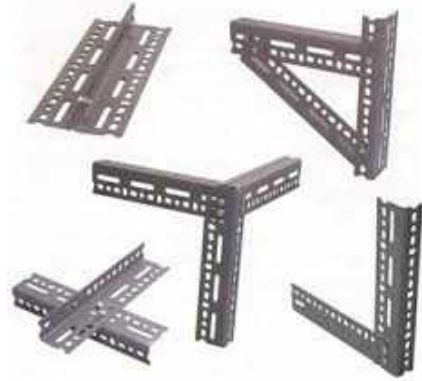

Angle Iron Framework

TECHNICAL SPECIFICATIONS M&E

SP-ME-TS-6 CABLES:

This specification covers design, manufacture, testing at manufacturer's works, supply, packing, forwarding and delivery from place of storage/ manufacturer's works to erection site including transit insurance, unloading, storage at site, testing, installation & commissioning at site for power AC/ control cables as per Specification.

1) General Design Requirement

- (i) All cables shall carry the corresponding full load current under site conditions. Design parameters considered while designing of the cables are as per following but not limited to -Maximum allowable design temperature rise under normal full load condition based on the material of cable insulation.
- (ii) Maximum short circuit current and its duration (fault clearing time).

2) Cables shall be laid under the following conditions,

- (i) In Air – Ambient Temperature of 40°C
- (ii) In Ground – Ground Temperature of 300 °C
- (iii) Depth of laying in ground – 750mm
- (iv) In conduits – Space factor of not more than 60%

Cables shall be capable of satisfactorily withstanding, without damage, during transportation to site, installation at site, and operation under normal and short circuit conditions of the various systems to which the respective cables are connected, when operating under the climatic conditions prevailing at the site as indicated in these specifications.

Cables shall be capable of giving satisfactory performance when laid in trays, trenches, conduit, and ducts and when directly buried in the ground.

Cables shall be capable of operating satisfactorily under a power supply system voltage variation of + 6% and frequency variation of + 2%.

Specific Requirement of 1.1KV LV Cables :

3) Power Cables - XLPE Insulated

Aluminium/Copper conductor, stranded, extruded XLPE insulated, extruded PVC inner sheathed (Type ST-2), GI wire/strip armoured, and extruded PVC outer sheathed (Type ST-2), class 2 as per IS 8130 / IS:7098 (Part- 1).

The conductors shall be electrolytic grade high conductivity annealed Copper or electrolytic grade Aluminium.

Core identification shall be by printed numerals.

The insulation over the individual conductor core will be colour coded. Core identification shall be as follows:

- (i) Single core: Red, Yellow, Blue, Black or Natural.

TECHNICAL SPECIFICATIONS M&E

- (ii) Two core: Red, Black.
- (iii) Three core: Red, Yellow and Blue.
- (iv) Four core: Red, Yellow, Blue and Black.
- (v) Five core: Red, Yellow, Blue, Black and Grey.
- (vi) For core exceeding five cores – two adjacent cores (Counting core and Direction core) in the each layer are coloured Blue and Yellow respectively and the remaining cores are Grey with numerals. Printed numerals shall be provided at every 50mm on each core.
- (vii) For 3.5 core cables three main cores shall be Red, Yellow and Blue and the reduced core shall be Black.

4) Power Cables - PVC Insulated

The 415V power cables shall be 1100V grade, stranded aluminium/ copper conductor, PVC insulated, extruded PVC inner and outer sheathed. All cables (outdoor & indoor) will be galvanised steel round/ flat wire armoured. Outdoor cables will be galvanised steel wire armoured. These cables shall generally conform to latest version of Indian Standards.

The conductors shall be electrolytic grade high conductivity annealed Copper or electrolytic grade Aluminium.

Core identification shall be by printed numerals.

The insulation over the individual conductor core will be colour coded. Core identification shall be as follows

- (i) Single core: Red, Yellow, Blue, Black or Natural.
- (ii) Two core: Red, Black.
- (iii) Three core: Red, Yellow and Blue.
- (iv) Four core: Red, Yellow, Blue and Black.
- (v) Five core: Red, Yellow, Blue, Black and Grey.
- (vi) For core exceeding five cores – two adjacent cores (Counting core and Direction core) in the each layer are coloured Blue and Yellow respectively and the remaining cores are Grey with numerals. Printed numerals shall be provided at every 50mm on each core.
- (vii) For 3.5 core cables three main cores shall be Red, Yellow and Blue and the reduced core shall be Black.

For PVC insulated cables - The PVC Type A compound insulation extruded on the conductors and PVC Type ST1 compound extruded as inner and outer sheath shall be suitable for maximum rated conductor temperature of 70deg C as per IS 5831.

TECHNICAL SPECIFICATIONS M&E

The construction, performance and testing of cables shall comply IS1554-Part-I for PVC cables. Conductor construction shall be as per IS: 8130. All galvanised steel round wire armour shall conform to requirements of IS 3975 -1979.

5) Control & Annunciation Cables:

The Annunciation cables will be 1100V grade, multicore, annealed high conductivity stranded copper conductor, PVC insulated with inner and outer PVC sheath and steel wire armouring (for outdoor cables). The cables shall generally conform to IS: 1554-1988 with relevant parts thereof. All control cables shall be with following specific requirements:

- (i) Copper conductor stranded class 2.
- (ii) Insulated with extruded PVC compound
- (iii) Provided with inner and outer sheath of extruded black PVC compound type ST-1.
- (iv) Galvanised steel armouring in the form of strip/ wire.
- (v) Core identification shall be by printed numerals.

6) Flexible Cable

- (i) 1.1kV grade stranded class 2 Copper conductor extruded inner sheathed PVC insulated multi-core flexible cables.
- (ii) The conductor shall be composed of plain annealed high conductivity Copper complying with IS 8130. The conductors shall conform to flexibility class 5 of IS 8130.
- (iii) Sheathing, Core identification and shielding of cables shall be as per IS 694.

7) Cable Termination:

Cable Glands

- (i) Double compression type cable glands shall be used. Cable glands shall be brass casting, machine finished and Nickel-plated to avoid corrosion and oxidation. Rubber components used in cable gland shall be of neoprene.
- (ii) For single core cables, gland shall be with brass ring.
- (iii) Cable glands shall be with metric threads.
- (iv) Cable glands shall be conical (& not flange type).

Cable Lugs

- (i) Cable lugs shall be of tinned copper, solder less crimping type for cu cables & AL lugs for the AL cables.
- (ii) The current rating of the lugs shall be same as that of the respective cable conductors.
- (iii) Ring type cable terminations shall be used.

TECHNICAL SPECIFICATIONS M&E

- (iv) Insulated lugs are not acceptable for any cable terminations.
- (v) Bi-metal strip/Bi-metallic lug shall be used whenever two different metals are to be connected together.
- (vi) Double hole extended neck (long barrel neck) type lugs shall be used in case of cables above 185 sq. Mm.
- (vii) Fork terminals shall be used for luminaires & decorative switch/ socket. [Pin terminals may be acceptable during execution only in case other terminals/ lugs cannot be accommodated.
- (viii) Reducer / wire pin terminals shall be avoided for MCB terminations. MCB terminations shall be with 'long palm terminals.
- (ix) All terminations in DBs/ enclosure for earthing & neutral busbars/ terminals shall be with ring type terminals.
- (x) All earthing terminations shall be with ring type lugs only.
- (xi) All control & interlock cable terminations shall be with ring type lugs.
- (xii) Anticorrosion/ anti-oxidation compounds shall be used for crimping lugs (This shall especially be ensured for Al cable terminations & any bimetallic terminations (Cu cable termination using tinned copper lugs).
- (xiii) If termination is done with crimping tool employing crimping die then forming dies shall be used to make the sector shaped conductor into a round conductor before crimping the lugs on the conductor. The lug must not be crimped directly on the sector conductor.
- (xiv) Before crimping the lug, the conductor shall be thoroughly cleaned and special jelly applied over it to prevent further oxidation.

TECHNICAL SPECIFICATIONS M&E

8) Testing of cables:

- (i) For PVC insulated cables - The construction, performance and testing of the cable shall comply with IS 1554 - Part 1.
- (ii) For XLPE insulated cables - The construction, performance and testing of the cable shall comply with IS 7098 - Part.
- (iii) Cables shall be subjected to routine and acceptance tests in accordance with standards specified. Test methods shall conform to IS 10810 (Methods of Test for Cables). Type tests and optional tests according to applicable standards shall be conducted on cables.
- (iv) All new cables shall be megger tested before laying and after jointing is completed, all L.V. cables shall be megger tested and HV cables pressure tested before commissioning. The voltage for pressure testing shall be per Appendix 'F' of IS: 1255. 1100/650 Volts grade cables shall be tested by 1000 Volts megger
- (v) Cable Cores shall be tested for :
 - (a) Continuity
 - (b) Absence of cross phasing
 - (c) Insulation resistance to earth
 - (d) Insulation resistance between conductors
- (vi) Contractor shall furnish all testing kit and instruments required for field testing whenever asked by the Site Engineer/Engineers representative.

9) Laying of Cables

- (I) Electrical installation work shall comply with all currently applicable statutes, regulations and safety codes in the locality/country where the installation is to be carried out.
- (II) Installation of cables shall be carried out generally as per IS:1255 or relevant applicable standards of any other country specified in the project specification.
- (III) Installation of cables shall include unloading, storing, laying, fixing, jointing, termination and all other work necessary for completing the job. Supply of glands and lugs whenever specified, together with other necessary materials for jointing and termination shall also be included in contractor's scope.
- (IV) Construction of cable trenches, provision of embedments and similar work involving civil items will be included in the electrical contractor's scope.
- (V) Cables shall be installed in trenches, trays, racks, tunnels, conduits, duct banks or directly buried.
- (VI) Cables to each circuit shall be laid in one continuous length. Cable jointing and splicing shall be done only after obtaining purchaser's permission.

TECHNICAL SPECIFICATIONS M&E

- (vii) Where cables are to be installed at temperatures below 3°C, they shall be heated to about 10°C for not less than 24 hours (in a heated building or in a tent with hot air heater) to facilitate laying (otherwise the bending would damage the insulation and protective coverings of cables). The cable laying must be carried out swiftly so as not to allow the cable to cool down too much.
- (viii) Cables shall be fitted on wall and ceiling by means of G. I. spacers & G. I. saddles or G.I. clamps of 18/22 SWG/1.21/0.71mm with G. I. strip at 30 cms. apart. The cable shall be terminated through lugs only.
- (ix) The cables shall be covered up to 2 mtrs. by using 'B' class G.I. pipe for vertical run at all junctions above floor level and also at the ground floor. For bunch of cables 18 SWG / 1.21mm 'C' section G.I. sheet covering in the floor slab for vertical run shall be provided.
- (x) The slab cut shall be resurfaced with cement concrete finished with plaster.
- (xi) The cost of 'C' type G.I. sheet covering and G. I. pipe shall be paid separately as per FME item rates. Cost of cement concrete with plastering is included in cost of cable.
- (xii) Cables shall be laid underground by using sand cushioning in the trenches and covered with horizontal bricks. The cost for excavation, sand, bricks etc. shall be paid separately.
- (xiii) Cables shall be laid in one-piece length without joints. Contractor shall furnish manufacturers test certificate along with cables supplied at site.
- (xiv) Any single cable that is to be run on brick walls, stone or plaster walls and ceilings shall be provided with G.I. spacers of 3 mm. thick by counter sunk screws. The cable shall be fixed on spacer by means of saddle of 18/22 SWG/1.21/0.71mm G.I. sheet. All cable shall run in straight line and without keeping any gap.
- (xv) Whenever groups of HV and LV cables are to be laid along the same route, suitable barriers to segregate these cables physically shall be introduced.

10) Outdoor Cable Installation

- (I) Directly buried cables shall be laid as per attached drawing and cable markers shall be provided. At least, one cable marker shall be provided if the length of the buried cable is less than 15 metres. Buried single core cables laid in trefoil formation shall be tied by plastic tapes or 3 mm dia. nylon cord every 750 mm.
- (II) Joints in directly buried cables shall be identified by joint markers at each joint location.
- (iii) In each outdoor cable run greater than 60 meters, some extra cable length shall be kept at a suitable point to enable a straight through joint to be made, should the cable develop fault at a later date.
- (iv) Where cables cross roads and water/oil/gas/ sewage pipes, the cables shall be laid in hume or steel pipes. For road crossings, the pipe for the cable shall be buried at

TECHNICAL SPECIFICATIONS M&E

not less than 1000 mm depth. Hume pipes shall be preferred to steel pipes from the point of view of corrosion.

- (v) For good sealing arrangement at entry points, suitable pipe sleeves, adequate in number and of adequate sizes shall be provided in building walls/slabs for passage of cables into a building from cable trays/racks/cable trenches located outside the buildings.

11) Bending Radii For Cables

Type and voltage grade of cable	Minimum bending radius	
	Single core	Multi core
a) PVC & XLPE insulated up to 1.1kV.	15D	12D
b) PVC & XLPE insulated above 1.1 kV and up to 11 kV.	15D	15D
c) XLPE insulated above 11 kV.	20D	15D
d) XLPE insulated 132 kV.	25D	-

- (i) The bending radii for various types of cables shall not be less than those specified below, unless specifically approved by the purchaser / manufacturer:
- (ii) The above values may be reduced to the extent of 70% when making only one bend such as in the case of installing an end termination.
- (iii) Saddle type clamps as per drawing attached to suit number of cables to be clamped at a particular location shall be used for clamping cables running along walls, ceilings, structures etc.
- (iv) wooden cleats when required for supporting vertical runs of one or more single core cables per phase, such as near transformer cable boxes, shall be made out of well seasoned wood and shall be painted with two coats of fire retarding paint of approved quality.

12) Earthing

- (i) Metallic sheaths, screens and armour of all multicore cables shall be earthed at both equipment and switchgear end.
- (ii) Sheath and armour of single core power cables shall be earthed at switchgear end only. For long lengths of cables, multiple earthing may have to be adopted to safeguard against the presence of standing voltages under normal as well as under fault conditions.

13) Trenches:

Trenches shall be made for laying underground cable by excavating the earth, breaking all types of layers, if any. Excavation shall be 750 mm deep and 600 mm wide and same shall be refilled with soft earth without any extra cost after the cable is laid in approved manner i.e. by using sand, bricks etc. Trenches shall be made good to the original surface. Cost of sand, bricks and refilling is included in cost of laying of cable.



Cables

TECHNICAL SPECIFICATIONS M&E

SP-ME-TS-7 G.I. CABLE TRAY PERFORATED TYPE:

Scope of work includes supply, installation, inspection at manufacturer's works, handling at site & fixing of hot deep galvanized sheet steel factory fabricated cable tray with accessories, wherever required / specified. The cable trays shall be supplied in standard lengths of 2500 mm and clear inside widths of trays shall be as follows

18-SWG up to 300 mm including 300 mm wide tray,

14-SWG for 400-1000 mm wide trays

The G.I. cable tray shall be of perforated type. Cable tray shall have suitable G.I. cover plate which shall be fixed over base tray by self threaded screws of G.I. Cable tray & cover plate with accessories like vertical outside / inside Elbow, Reducer, Bends, Tees, and Cross etc. shall be thoroughly hot dip galvanised. Galvanizing shall be as per IS: 2629/4759.

G.I. coupler plates with hardware shall also be provided. The cable tray assembly combined with cover plates shall be properly earthed. All the other material shall be conforming to relevant IS codes.

G. I. Cover from 14 SWG MS sheet and then hot dip galvanised for the required tray size & knock out holes (two holes per meter) on both sides shall be provided.

Vertical trays (raceways) and all outdoor cable trays shall be provided with removable 14 SWG thick G.I. cover

Earthing: 2 Runs of GI earth strip of suitable size shall be run throughout the length of Cable tray. Cable tray shall be connected to main earth grid at minimum 2 places. For multitier trays 2 runs of GI earth strip shall be laid in lower most tiers and other tiers shall be earthed at 10 mtr interval.

Support arrangement:

For wall mounting arrangement, Z sections of G.I. of size 50mm X 25mm X 50mm & of 14/16 SWG, shall be provided as a support for fixing cable tray. These sections shall be fixed to the wall by coach screws or anchor-fastners firmly. Cable tray shall be fixed on these Z sections by G.I. nut bolts of suitable size. These Z sections shall be provided at a distance of one meter of cable tray.

For ceiling suspended type arrangement, 25mm X 25mm X 3mm thick G.I. angle support or combination of Z section & 8mm threaded G.I. rods, shall be provided for cable tray up to 300 mm wide. These supports shall be fixed to the ceiling by anchor-fastners firmly. And for cable trays, from 300 mm up to 600 mm width, 40mm X 40mm X 5mm thick G.I. angle support shall be provided which shall be fixed to the ceiling by anchor-fastners firmly. Tier type or layered arrangement shall be done wherever possible, for very effective use of cable tray & Z sections.

Items / Accessories / parts/ hardware which are not specified but required for neat & proper completion of work, is considered as part of specification. Reinstatement as original, is also a part of scope of specification



G.I. Cable Tray Perforated Type

TECHNICAL SPECIFICATIONS M&E

SP-ME-TS-8 G.I. CABLE TRAY LADDER TYPE:

Scope of work includes supply, installation, inspection at manufacturer's works, handling at site & fixing of hot deep galvanized sheet steel factory fabricated ladder type cable tray with accessories, wherever required / specified. The cable trays shall be supplied in standard lengths of 2500 mm and clear inside widths of trays shall be as follows

16-SWG up to 300mm including 300mm wide tray,

12-SWG for 500-1000mm wide trays

Cable tray shall have Runners/Side channels of size 20 X 75 X 20mm while Rungs of size 32 X 20mm and Rung interval of 250mm.

The G.I. cable tray shall be of ladder type made out of rolled angle & strips. Cable tray & its accessories like Reducer, horizontal/vertical Elbow, Tees, Cross etc., shall be thoroughly hot dip galvanised. Galvanizing shall be as per IS: 2629/4759. G.I. coupler plates with hardware shall also be provided. All the other material shall be conforming to relevant IS codes.

G. I. Cover from 14 SWG MS sheet and then hot dip galvanised for the required tray size & knock out holes (two holes per meter) on both sides shall be provided.

Vertical trays (raceways) and all outdoor cable trays shall be provided with removable 14 SWG thick G.I. cover

Earthing: 2 Runs of GI earth strip of suitable size shall be run throughout the length of Cable tray. Cable tray shall be connected to main earth grid at minimum 2 places. For multitier trays 2 runs of GI earth strip shall be laid in lower most tiers and other tiers shall be earthed at 10 mtr interval.

Support arrangement:

For wall mounting arrangement, Z sections of G.I. of size 50mm X 25mm X 50mm & of 14/16 SWG, shall be provided as a support for fixing cable tray. These sections shall be fixed to the wall by coach screws or anchor-fasteners firmly. Cable tray shall be fixed on these Z sections by G.I. nut bolts of suitable size. These Z sections shall be provided at a distance of one meter of cable tray.

For ceiling suspended type arrangement, 25mm X 25mm X 3mm thick G.I. angle support or combination of Z section & 8mm threaded G.I. rods, shall be provided for cable tray up to 500 mm wide. These supports shall be fixed to the ceiling by anchor-fasteners firmly. And for cable trays, from 500 mm up to 1000 mm width, 40mm X 40mm X 5mm thick G.I. angle support shall be provided which shall be fixed to the ceiling by anchor-fasteners firmly.

Items / Accessories / parts/ hardware which are not specified but required for neat & proper completion of work, is considered as part of specification. Reinstatement as original is also a part of scope of specification.



G.I. Cable Tray Ladder Type

TECHNICAL SPECIFICATIONS M&E

SP-ME-TS-9 G.I. FLOOR TRUNKING / DUCT / RACEWAY:

Scope of work includes supply, installation, inspection at manufacturer's works, handling at site & fixing of sheet steel factory fabricated trunking / duct / raceway with internal partition, junction boxes wherever required/specified of required sizes of thickness 14 SWG GI for trunk and removable cover, knock-out holes (two holes per meter) on both sides & fixing accessories, earthing with 8 SWG Copper wire complete as required, including supports, bends etc. as per site requirement & specifications as below

The G.I. floor trunking / duct / raceway shall be made of galvanized plate sheets. Trunking with its accessories like junction boxes, cover plates of suitable sizes, shall be thoroughly hot dip galvanized. Galvanizing shall be as per IS:2629/4759. G.I. coupler plates with hardware shall also be provided. All the other material shall be conforming to relevant IS codes.

Tier type or layered arrangement shall be done wherever possible, for very effective use of Trunking/Duct/Raceway & Z sections.

Junction Box

Junction Boxes shall be provided for all workstations, for all cable bends; in case of straight run, junction box shall be provided at every 3m interval. Installations:-

Using Multi-Compartment Trunking / Duct / Raceway, knock-out entry shall be provided at a distance of 500 mm for Compartments & Trunking/Duct/Raceway. Knock-out entries are meant as an outlet for cables and must be punched by the fabricator himself. The only required knock-outs entries, from which cables are required to be pulled, shall be properly finished by grinder to remove the burr while installation, to avoid damage while pulling the cables through the knock-outs.

For installations **under flooring**, Floor-Raceway of 14 SWG (2 mm) thickness shall be used. Suitable Aluminium / GI clamps shall be provided while fixing of floor Raceway.

For **wall mounting arrangement**, Trunking / Duct / Raceway of 18 SWG (1.2mm) thickness shall be used. Also Z sections of G.I. of size 50mm X 25mm X 50mm & of 14/16 SWG, shall be provided as a support for fixing Trunking/Duct/Raceway. These sections shall be fixed to the wall by coach/wooden screws (35 X 8) firmly. Trunking / Duct / Raceway shall be fixed on these Z sections by G.I. nut bolts of suitable size. These Z sections shall be provided at a distance of one meter of Trunking / Duct / Raceway.

For **ceiling suspended type arrangement**, Trunking / Duct / Raceway of 18 SWG (1.2mm) thickness shall be used. And 25 mm X 25 mm X 3 mm thick G.I. angle support or combination of Z section & 8 mm threaded G.I. rods, shall be provided for Trunking / Duct / Raceway. These supports shall be fixed to the ceiling by anchor-fasteners firmly.

Items /Accessories / parts / hardware which are not specified but required for neat & proper completion of work, is considered as part of specification. Reinstatement as original is also a part of scope of specification.



G.I. Trunking / Duct

TECHNICAL SPECIFICATIONS M&E

SP-ME-TS-10 PVC TRUNKING:

Scope of work includes supply, installation, inspection at manufacturer's works, handling at site & fixing of factory fabricated fire resistant, smoke suppressing, temperature stable, self extinguishable PVC trunking, with or without internal partition / compartment, wherever required / specified, of required sizes including providing suitable & removable PVC cover & fixing accessories as per site requirement & specifications as below.

The PVC trunking shall be complete with its suitable accessories like cover plate, junction box with lid, Bush adapters for cable entry/exit, and their various types. PVC trunking shall be as per IS:14927-part2. All the material shall be conforming to relevant IS codes..

Installations:-

For installations using Multi-Compartment Trunking, knock-out entry shall be provided at a distance of 500 mm for Compartments & Trunking.

This trunking shall be fixed to the wall by plated metallic screws (35 X 8) fitted in properly drilled holes for firm support, at an interval of 45 cms.

Knock-out entries are meant as an outlet for wires / cables. The cables, which need to be pulled from required knock-outs entries/exits, shall have suitable bush-adapters, to avoid damage while pulling the cables through the knock-outs. Round shaped Knock-out entries/exits shall be made by hole-saw cutter of appropriate diameter in consideration with bush-adapter & conduits / casing-capping. Conduit / casing-capping, as per requirement, shall be provided while taking access of wires/cables from PVC trunking, through bush-adapters up to PVC outlet box (RJ-11/45/light point). This casing-capping / conduit is not covered under scope of trunking provision.

Items / Accessories / parts / hardware which are not specified but required for neat & proper completion of work, is considered as part of specification. Reinstatement as original, is also a part of scope of specification



PVC Trunking

TECHNICAL SPECIFICATIONS M&E

SP-ME-TS-11 CABLE JOINTS: FOR CAST RESIN STRAIGHT THROUGH JOINTS:

Scope of work includes supply, installation, testing, commissioning, handling at site of Heat Shrinkable cast resin straight through joints:

Straight through joints suitable for following sizes 1.1 kV grade stranded Cu/Al conductor, XLPE/PVC, extruded PVC inner and outer sheathed, galvanised steel round or strip armoured cables with required all necessary accessories.

The cable joints shall have high electrical insulation values. Good mechanical strength, good resistance against UV- radiation, alkaline earths and chemical agents. It shall prevent ingress of water due to special sealants & Adhesive. Lined corrosion protection tubing kits shall conform to requirements of C-81, BIS & other international standards.



Cable Joints

SP-ME-TS-12 MAIN / SUBMAIN WIRING AND POINT WIRING:

1) General Requirement –

All the wiring shall be done on the distribution system with the main and branch distribution boards at convenient physical and electrical load center.

All runs of wiring shall be laid in such a manner that crossing is avoided.

All runs of wiring and exact position of all points and switchgear shall be first marked on the buildings itself and approved by the Engineer.

Single/multi-strand single/double sheathed PVC Wires shall be from fresh stock. Lights and fans shall be wired on a common circuit, including socket outlets.

As regards power circuits, in no case, there shall be more than 2(two) power points on each circuit.

When conductors pass through walls and floors, the conductors shall be wired through rigid pipe PVC sleeves of suitable size permitting easy passing of the wires. The ends of sleeves shall be neatly fixed with PVC bushings.

TECHNICAL SPECIFICATIONS M&E

All ceiling fans shall be wired to ceiling rose through connector to which fan rod wires shall be connected and suspended from hooks or shackles with the insulators between hooks and suspended rods.

Canopies on top and bottom of suspension rod shall be effectively suspended and connected to fan motors respectively.

Fittings with all types of luminaries shall be suspended with suspension rods, wherever specified, from the ceiling with special couplers fixed on to single teak wood blocks or suitable size G. I. Clamp. The suspension rods shall be screwed to the couplers and end of the pipe shall touch within coupler to maximum extend and shall in addition be secured by means of split pins. Two such suspension rods shall be provided for each fitting.

Fittings with all types of luminaries shall be supplied complete with all the standard accessories and they shall be duly wired. Ceiling rose shall be of 3-plated terminal so as to terminate earthing wire.

All ceilings roses, brackets, pendants and accessories attached to walls or ceilings shall be mounted on PVC. Screws shall be used for attaching fittings and accessories to their base blocks.

Suitable size danger boards in MARATHI & ENGLISH shall be fixed at every service position & where supply voltage exceeds 230 volts.

2) Main / submain wiring:

Submain wiring shall mean wiring from main/sub distribution board to another.

Circuit wiring shall mean wiring from distribution board to the 1st tapping point inside the switch box from where point wiring starts.

3) Measurement of Submain and circuit wiring –

Circuit and submain wiring shall be measured on linear basis along the run of the wiring. The measurement shall include all lengths from end to end of conduit or channel as the case may be, exclusive of interconnections inside the switchboard etc. The increase on account of diversion or slackness shall not be included in the measurement.

The length of the circuit wiring with two wires shall be measured from the distribution board to the nearest switch box from which the point wiring starts. Looping of switch boxes also will be counted towards circuit wiring, measured along the length of conduit / channel.

When wires of different circuits are grouped in a single conduit/channel, the same shall be measured on linear basis depending on actual number and size of wire run.

Protective (loop earthing) conductors, which run along the run along the circuit and submain wiring, shall be measured on linear basis.

4) Point Wiring-

A point (other than socket outlet point) shall include all work necessary in complete wiring to the following outlets from the controlling switch or MCB.

TECHNICAL SPECIFICATIONS M&E

- (i) Ceiling rose or connector (in the case of points for ceiling /exhaust fan points, prewired light fittings and call bells)
- (ii) Ceiling rose (in case of pendant except stiff pendants)
- (iii) Back plate (in case of stiff pendants)
- (iv) Lamp holder (in case of goose neck type wall brackets, batten holder and fittings which are not prewired)

Following shall be deemed to be included in light point wiring.

- (v) Conduit/ channel as the case may be, accessories for the same and wiring cables between the switch box and point outlet, loop protective earthing of each fan/light fixture.
- (vi) All fixing accessories such as clips, screws, phil plug, rawl plug etc as required.
- (vii) Metal or PVC switch boxes for control switches, regulators, sockets etc recessed or surface type and phenolic laminated sheet cover over the same.
- (viii) Outlet boxes, junction boxes, pull through boxes etc but excluding metal boxes if any, provided with switchboards for loose wire / conduit terminations.
- (ix) Any special block required for neatly housing the connector in batten wiring system.
- (x) Control switch or MCB, as specified.
- (xi) 3 pin or 6 pin socket, ceiling rose or connector as required
- (xii) Connection to ceiling rose, connector, socket outlet, lap holder, switch, etc.
- (xiii) Bushed conduit where cables pass through wall etc.

Light/fan point wiring shall be carried out with 2 (two) wires of minimum 1.5 sq. mm. Multi strand copper PVC insulated wire, 1100 V grade along with earth continuity conductor of same size.

Wiring in PVC conduit - Rigid PVC pipe conforming to IS: 9537 (Part-III) marked 'Medium' shall be used for surface mounting wiring & PVC conduits marked 'Heavy' shall be used for concealed wiring. All PVC accessories shall be conforming to I. S. 3419.

Wiring in Casing n Capping - Casing-N-Capping and accessories shall be of same make as per approved make list and as per BS 4678 Part IV and I.S. 14927 Part I. In casing-N-capping wires, shall be laid in one length without any joint. Casing-N -Capping shall have minimum joints. All the dimensions and thickness shall be as per IS 14927 (Part I & 2). Instead of internal working sizes, all external dimensions shall be indicated and included in specifications.

The casing-n-capping shall be used as per following sizes with thickness of 1.2mm: -

- i) 20mm, ii) 25mm, iii) 38mm, iv) 50mm

And screwed to the wall/ ceiling at a distance of 30 cms to 45 cms. The accessories shall be in conjunction with casing-n-capping.

TECHNICAL SPECIFICATIONS M&E

Wiring in MS conduit- In HGMS conduit black stove enameled ERW steel conduit pipe IS 9537 (part II) ISI mark, 16 SWG/1.62mm of surface mounting wiring and 14 SWG/2mm for concealed wiring shall be used

Wiring in G.I. conduit- In GI conduits (Hot deep galvanized) 16 SWG/1.62mm of surface mounting wiring and 14 SWG/2mm for concealed wiring shall be used.

ERW MS (Black stove enameled)/GI conduit shall be of 16 SWG as per IS 9537-part II 1.1KVA grade fixed on wall/ ceiling for surface mounting wiring and 14 SWG for concealed point wiring using MS/ GI saddles and spacers 03Mtr. Apart with screws, Tees, bends, couplings, junction box of 16 SWG only and copper earth clips of 22 SWG /0.71mm,10 mm width shall be used.

Group control point wiring –

In the case of Group control point wiring for group of points controlled by 1 no. 15 A SP switch, wiring shall be carried out with 3 wires of 1.5 sqmm copper PVC wire. Earthing wire shall be 1 sqmm.

The charges of Bell/ Buzzer, Bell push, Bell indicator, are included in the cost of the bell point wiring.

Point wiring for Socket outlet points-

Power point wiring shall be carried out with 3 wires of single PVC insulated copper conductor of size 2.5sqmm, multi strand 1100V grade with earth conductor of 1.5 sqmm size. (Green color insulation) complete with set of combined 5A/6A and 15 A socket with 1 no. 15A SP switch, indicating lamp and control fuse on suitable size PVC boards

TECHNICAL SPECIFICATIONS M&E

Capacity of circuits-

Lighting circuit shall feed light/fan/call bell points. Each circuit shall not have more than 800W connected load or more than 10 points. However in case of CFL points where load per point may be less, number of points may be suitably increased.

Power circuit in non residential buildings will have only one outlet per circuit.

Each power circuit in residential building can feed following outlets-

Not more than 2 nos. 16A outlets

Not more than 3 nos. 6A outlets

Not more than 1 no. 16 and 2nos 6A outlets.

Load more than 1kW shall be controlled by suitably rated MCB and cable size shall be decided as per calculations.

Installation

Nominal Cross sec. Area (mm ²)	Overall dia (mm)	Conduit diameter (mm)			
		20	25	32	40
		Number of wires			
1.50	3.4	3	6	9	-
2.50	4.2	2	4	8	-
4.00	4.8	2	3	6	-
6.00	5.6	-	3	6	-
10.00	7.0	-	2	4	5

The size of conduit shall be selected in accordance with the number of wires permitted under table given above. The minimum size of the conduit shall be 20 mm dia unless otherwise indicated or approved. Size of wires shall be not less than 1.5 sq. mm copper or 2.5 sq. mm aluminium, but shall be as specified in the schedule of work.

Conduits shall be kept at a minimum of 100 mm from the pipes of other non-electrical services

Following colour coding shall be followed in wiring-

- Phase – Red/Yellow/Blue(3phase wiring)
- Live – Red(1 phase wiring)
- Neutral- Black
- Earth – Green

TECHNICAL SPECIFICATIONS M&E

Supply & laying of 2.5 SQ MM X 1 Core, FR PVC insulated copper conductor wire (ISI marked), shall be done as required.

Supply & laying of 1.5 SQ MM X 1 Core, FR PVC insulated copper conductor wire (ISI marked), shall be done as required.

The crone box shall be 10 pair. A Krone module shall consists of two rows of contacts, the upper row for permanent connection, the lower row for jumper wires. Each Krone connection slot shall accept up to two wires of appropriate diameter. Krone shall be an insulation displacement connection type which totally eliminates the need to strip, solder or screw connect wires. Connections are shall be made using the Krone inserter tool on a slot in the module

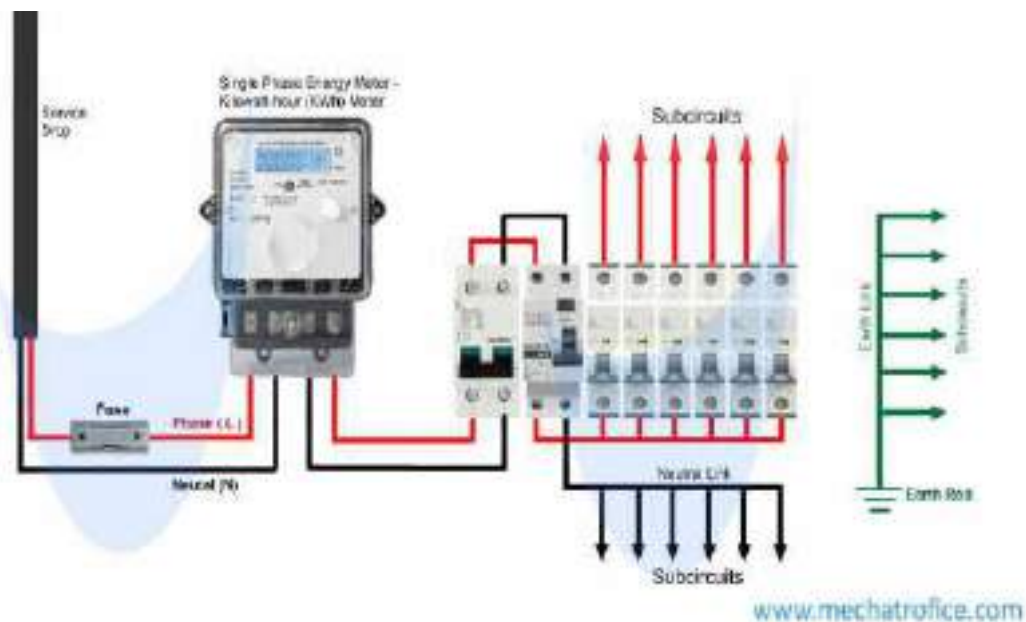

Mains/ Submain Wiring

TECHNICAL SPECIFICATIONS M&E

SP-ME-TS-13 POLES AND ACCESSORIES:

Design, engineering, manufacture, testing at factory, packing & forwarding, delivery to site, unloading and handling at site, assembly, installation, testing and commissioning of street light poles with embedded junction box inclusive of terminals, 3Cx 2.5 sqmm PVC insulated multistranded flexible copper cable from Junction box to the luminaires, termination at both ends and other accessories. Foundation for the pole erection and all civil works shall be in the scope of the contractor

1) Swedged Pole :

- (i) Pole shall be fabricated from steel tubular pipes. The ERW swedged poles shall be as per IS 2713 Part-(1-3).
- (ii) M.S. sleeves of 460 mm in length shall be welded in on the bottom portion of the pole from the M.S. base plate of 300 mm x 300 mm. x 5 mm. thick. Suitable top section canopy (hood) shall be provided to the pole in such a way that the center of the sleeve shall be at ground level, i.e., half the sleeve shall be buried and half in the muffing
- (iii) Three wires of 2.5 sq. mm. multi strand. copper conductor shall be provided in PVC sleeves from C.I. Box to the fixture. 1.5 mtr long, 'B' class G.I. pipes of 32/40 mm. dia. shall be provided for incoming and outgoing cables and shall be properly fixed with at least three nos. of G.I. clamps of 18 Gauge. The rate of wire, G.I. pipe, sleeve and clamps are included in the rate of pole.
- (iv) Pole shall be erected in plumb complete with excavation suitable to bury the pole to 20 % of height of the pole .The pole shall be provided with cement concrete foundation in 1:2:4 proportion complete with suitable coping, muffing with plaster finish shall be provided above ground level up to 45 cms. in circular shape. The rate of concrete foundation coping, muffing, plastering is included in the rate of pole.
- (v) The steel poles shall be coated with bituminous preservative paint on the inside as well as embedded outside surface. Exposed outside surface of steel poles and G.I. pipe for cable protection shall be painted with one coat of red lead oxide primer. After completion of installation two coats of synthetic enamel or / two coats of silver paint in approved manner.
- (vi) Earthing For each lighting pole shall be done with 25mm Dia. 1500mm long GI Earth rod. The (25x3)mm 2 runs GI earth strip shall be run from earth rod to pole JB and JB to fixture earthing shall be done with 12SWG GI Wire.

TECHNICAL SPECIFICATIONS M&E

2) Garden Poles :

- (i) 'C' class G.I. pipe 4.5 mtrs in length shall be erected with 300 mm x 300 mm x 5 mm. M.S. plate welded at the bottom and suitable canopy at top.
- (ii) 'B' class G.I. pipes of 32/40 mm. dia. shall be shall be erected straight for incoming and outgoing cable protection.
- (iii) Pole shall be erected in plumb complete with excavation suitable to bury the pole to 20 % of height of the pole. The pole shall be provided with cement concrete foundation in 1:2:4 proportions complete with suitable coping, muffing with plaster finish shall be provided above ground level up to 45 cms. in circular shape.
- (iv) G.I. pipe for cable protection shall be painted with two coats of synthetic enamel or / two coats of silver paint in approved manner
- (v) 2.5 sq.mm. Multi strand PVC insulated copper wire shall be provided in sleeve from C.I. Box to fixture.
- (vi) Earthing For each lighting pole shall be done with 25mm Dia. 1500mm long GI Earth rod. The (25x3)mm 2 runs GI earth strip shall be run from earth rod to pole JB and JB to fixture earthing shall be done with 12SWG GI Wire.
- (vii) Rate of coping, concreting, painting, muffing, earthing, wiring and excavation is included in the rate of item of pipe pole. 'C' class G.I. pipe shall be as per list of approved material. Vertical run 'B' class G.I. pipe for cable protection shall be installed without any extra cost.

3) C. I. Juntion Box:

Providing, fixing and connecting weather proof pole mounting cast iron box, hinged door with locking arrangement, complete with fuse cut-outs, terminal block mounting arrangement etc. up to 6 sq. mm. cable, the size of the boxes shall not be less than 6" x 5" (150 mm x 125 mm) and above 6 sq. mm. cable size, box shall be of 8" x 5" (200 mm x 125 mm.) or standard size available in the market. Box shall be duly painted in approved manner as per TS-15 (a). Cost of painting is included in cost of C.I. Box.

Side Arm:

- (i) Supply and fixing overhead side arm of 1 (one) meter long fabricated from 40 mm to 65 mm dia. 'B' class G.I. pipe as required and clamped to have angle of 100 to 125 degrees to vertical as per site requirement complete with necessary gusset plate of size 200 mm x 200 mm x 3 mm thick. G.I clamps for clamping over the pole as above and all G.I. hardware etc. for mounting fixture shall be provided.
- (ii) Fixing of side arm shall be in accordance with final instruction issued at site. Suitable locking arrangement shall be provided so that fixtures shall not move after fixing in position on pole.
- (iii) The diameter of other end of the arm shall be suitable for fixing the specified light fixture. The diameter of Single Arm, Double Arm & Triple Arm bracket's shall be

TECHNICAL SPECIFICATIONS M&E

suitable to fix on top of the pole and shall not be less than 300 mm in length, the canopy shall be fixed on top of the bracket. The bracket shall be painted in approved manner. The charges for the above work are included in the cost of the arm.

4) Swan Neck Type Bracket:

Swan neck type bracket shall be made from 40 mm 'B' class G. I. pipe for fixing HPMV / HPSV lamp fixtures mounting on wall / shed etc. G.I Pipe shall be fixed on wall with saddle & spacers at every 300mm. In case where the pipe required to be mounted on trusses, it shall be fixed with nuts & bolts.

5) Galvanized Octagonal Poles

- (i) Design: - The Octagonal Poles shall be designed to withstand the maximum wind speed as per IS 875. The top loading i.e. area and the weight of fixtures are to be considered to calculate maximum deflection of the pole and the same shall meet the requirement of BS: 5649 Part VI 1982.
- (ii) Pole shaft: - The pole shaft shall have octagonal cross section and shall be continuously tapered with single longitudinal welding. There shall not be any circumferential welding. The welding of pole shaft shall be done by Submerged Arc Welding (SAW) process. All octagonal pole shafts shall be provided with the rigid flange plate of suitable thickness with provision for fixing 4 foundation bolts. This base plate shall be fillet welded to the pole shaft at two locations i.e. from inside and outside. The welding shall be done as per qualified MMAW process approved by Third Party Inspection agency.
- (iii) Door opening: - The octagonal Poles shall have door of approximate 500 mm length at the elevation of 500 mm from the Base plate. The door shall be vandal resistance and shall be weather proof to ensure safety of inside connections. The door shall be flush with the exterior surface and shall have suitable locking arrangement. There shall also be suitable arrangement for the purpose of earthing. The pole shall be adequately strengthened at the location of the door to compensate for the loss in section. Door shall be provided with allen bolt chain for safety from theft.
- (iv) Material for Octagonal Poles shall be HT Steel Conforming to grade S355JO: Base plate shall be FE 410 conforming to IS 226/ IS 2062: Foundation Bolts shall be of EN.8 grade.
- (v) Welding :- The welding shall be carried out confirming to approve procedures duly qualified by third party inspection agency. The welders shall also be qualified for welding the octagonal shafts.
- (vi) Pole sections: - The Octagonal Poles shall be in single section (up to 11 mtr). There shall not be any circumferential weld joint
- (vii) Galvanization: - The poles shall be hot dip galvanised as per IS 2629 / IS 2633 / IS 4759 standards with average coating thickness of 70 micron. The galvanizing shall be done in single dipping.

TECHNICAL SPECIFICATIONS M&E

- (viii) Earthing Terminals: - Suitable earth terminal using 12 mm diameter stainless steel bolts shall be provided at a convenient location on the base of the Mast lightning and electrical earthing of the mast.
- (ix) Fixing Type: - The Octagonal Poles shall be bolted on a pre-cast foundation with a set of four foundation bolts for greater rigidity.
- (x) Top Mountings:-The galvanized mounting bracket shall be supplied along with the Octagonal Poles for installation of the luminaries. Cost is not included in the cost of pole.

Height	Top Dia. (A/F)	Bottom Dia. (A/F)	Sheet Thickne ss	Base Plate Dimensions (L x B x T)	Foundation Bolt			
					Bolt Size (no. x dia.)	Pitch Circle Dia. (PCD)	Bolt Length (mm)	Projecte d Bolt Length (mm)
(mtr)	(mm)	(mm)	(mm)	(mm)	(mm)	(mm)	(mm)	(mm)
3	70	130	3	200x200x12	4x16 Dia	200	450	80
4	70	130	3	200x200x12	4x16 Dia	200	450	80
5	70	130	3	200x200x12	4x16 Dia	200	600	80
6	70	130	3	220x220x12	4x20 Dia	205	600	100
7	70	130	3	220x220x12	4x20 Dia	205	700	100
8	70	135	3	225x225x16	4x20 Dia	210	750	100
9	70	155	3	260x260x16	4x24 Dia	250	750	125
10	70	175	3	275x275x16	4x24 Dia	270	750	125
11	90	210	3	300x300x20	4x24 Dia	300	750	125
12	90	240	3	320x320x20	4x24 Dia	325	850	125

REINFORCED POLYMER COMPOSITE POLES (GRP POLES):

- (i) Design, engineering, manufacture, testing at factory, packing & forwarding, delivery to site, unloading and handling at site, assembly, installation, testing and commissioning of GRP Poles (Glass reinforced Polymer) street lighting poles.
- (ii) GRP Poles shall be designed and tested as per the ASTM (American standard) standard.
- (iii) The GRP poles shall be conical in shape with embedded type mounting arrangement having following specification. Process used in manufacturing of GRP Poles shall be Centrifugal process. Materials for GRP poles are by combining fabric glass

TECHNICAL SPECIFICATIONS M&E

reinforcement like mats, technical fabrics and unsaturated polyester resins system. Standard GRP poles are designed for a wind speed of 180 km/hr.

(iv) Manufacturer shall provide test certificate from R.L.T., Govt. Labs to substantiate following.

- (a) Specific Gravity: - 1.65 kg/dm³
- (b) Glass Content: - 45-55%
- (c) Water Absorption: - 0.5%
- (d) Tensile Strength: - 400+50MPa
- (e) Flexural Strength: - 350+50MPa
- (f) Compressive Strength: - 200+50MPa
- (g) Impact Strength: - >180 kj/m²
- (h) Dielectric Strength: - 3-7 KV/mm
- (i) Thermal Conductivity: - 0.2-0.3 Kcal/mHc
- (j) Coefficient of Linear Expansion: - 15-17°c⁻¹ 10⁻⁸

GRP poles will be made available with single arm and double arm bracket.

TYPE	HEIGHT (MM)	Top Dia	Bottom Dia	Avg Thickness
CONICAL	3000	76	127	6
CONICAL	4000	76	143	6
CONICAL	5000	76	160	6
CONICAL	6000	76	176	6
CONICAL	7000	76	196	6
CONICAL	8000	76	210	6
CONICAL	9000	76	227	6
CONICAL	10000	76	243	6
CONICAL	11000	76	260	6
CONICAL	12000	76	227	10
CONICAL	13000	76	293	10

Junction Box:-

- (i) Embedded Junction Box: The JB should be integral type. The JB housing should be IP54 & the access door should be weather proof. The Cable access, exit & leads should be securely locked by a saddle clamp coated with Silicone Rubber grommets.

TECHNICAL SPECIFICATIONS M&E

The JB should be fitted with one no. 6A SP MCB, & 2 Way connector suitable for cable up to 3Cx16sq mm

(ii) External Junction Box: The JB should be SMC (Sheet Molding Type). The JB housing should be IP54. The Cable access, exit & leads should be securely locked by a saddle clamp coated with Silicone Rubber grommets. The JB should be fitted with backlite sheet & 2 Way, 3Way, 4Way terminal connector box suitable for cable up to 3Cx16sq mm.

(iii) BASE MOUNTING: GRP Poles should have following mounting arrangement:

- FLANGE BASE type: Metallic base frame integrated with the pole by in-situ bonding & should be covered with GRP Coating.
- Embedded Type



Garden Pole



Octagonal Pole



Swedge Pole

TECHNICAL SPECIFICATIONS M&E

SP-ME-TS-14 SURFACE MOUNTING MONOBLOCK PUMP SETS

These specifications are applicable for selection, supply and erection of electric mono-set pumps for agricultural and water supply purposes.

- (i) Motor rating : 1 HP to 15 HP
- (ii) Discharge capacity : 40 LPM to 1500 LPM
- (iii) Head range : 12 m to 65 m

Mono-block Pump Set

The pump shall conform to IS 9079: 2002 amended up to date.

These specifications are applicable for Mono-block Pump Set. The contractor shall design and select suitable pump set along with base plate to meet the operational requirement as per the site condition. The pump shall be equipped with all required accessories like priming cup, air vent, suction & delivery pressure gauge etc. The cost shall be included in the pump cost.

Impeller shall be statically/dynamically balanced to Grade G 6.3 of IS 11723 (Part 1).

The pump rating shall be suitable to meet the operational requirement as per the site condition. Site engineer before commencement of work shall approve the selection of the pump sets, pump installation and layout drawing.

Electric Motor

The electric motor shall be squirrel cage, induction type TEFC suitable for operation on 415V, 3 phase, 50 c/s electric supply with required RPM capable of delivering the rated output (a) with the terminal voltage differing from its rated value by not more than +6% and -15% (b) the frequency differing from its rated value by not more than 3% or (c) any combination of (a) and (b).

Motor shall be capable of running continuously at a B. H. P. (brake horse power) not less than 10% in excess of that absorbed by pump set under any operating conditions

Starting current for the motor shall be limited to 6 times the full load current

Motor shall have minimum starting torque of 140% FLT and maximum starting torque 200% FLT. It shall have 100% FLT during running condition.

Sr.	Component	Alternate-1	Alternate-2
1.	Pump Casing	Cast Iron FG 200 of IS 210	Cast Iron FG 200 of IS 210
2.	Impeller	Cast Iron FG 200 of IS 210	Bronze grade LTB2 of IS 318
3.	Casing and Impeller ring	Cast Iron FG 200 of IS 210	Bronze grade LTB2 of IS 318
4.	Shaft	SS 410	SS 410
5.	Shaft sleeve	Bronze grade LTB2 of IS 318	Stainless Steel Gr 04Cr13/ Gr 12Cr13/ Gr 30Cr13 as per IS

TECHNICAL SPECIFICATIONS M&E

Sr.	Component	Alternate-1	Alternate-2
			6603
6.	Bush	Nitrile Rubber/ Bronze grade LTB2,3 or 4 of IS 318	Nitrile Rubber/ Bronze grade LTB2,3 or 4 of IS 318

Contractor shall submit the motor details including manufacturer's guarantee for efficiency and P.F. at full load, no load, 3/4 load, 1/2 load and main duty point, and locked rotor current. Contractor shall also furnish full load current in amps for motor, speed in rpm and mounting details frame size etc.

Material of Construction

The material of construction shall be suitable for application and site conditions. Typical material of construction is indicated below merely for guidance of the manufacturer and the user:

6) TESTING:

Each pump-motor set shall be factory tested at manufacturer's works as per guidelines for testing of I.S. 11346 and IS 7538.

7) CERTIFICATES:

Contractor shall furnish:

Performance characteristic.

Catalogue of pump set and details of pump and its motor.

Manufacturing test certificate, Guarantee card and list of parts for the pump sets.

Operation and maintenance manuals for the pump set.

Drawings showing cross sections of pumps, mounting arrangements, list of materials and necessary curves along with their offer.

In the event of any pump failing to meet the specified requirement of pump set it shall be modified and retested until the requirements are fulfilled. The inspections and testing of the pump set are at contractors cost. Engineers of the Corporation may witness the shop test.



MonoBlock Pump

TECHNICAL SPECIFICATIONS M&E

SP-ME-TS-15 OPEN WELL SUBMERSIBLE PUMP SETS:

These specifications are applicable for selection, supply and erection of submersible open-well pump sets of:

- (i) Motor rating : 0.75 HP to 10 HP
- (ii) Discharge capacity : 900 LPM to 120 LPM
- (iii) Head range : 15 m to 80 m

The pump rating shall be suitable to meet the operational requirement as per the site condition. Site engineer before commencement of work shall approve pump installation and layout drawing

Sr.	Component	Alternative- 1	Alternative- 2	Alternative- 3
	PUMP			
1.	Pump Casing, Diffuser chamber	Cast Iron IS 210 FG 200	Cast Iron IS 210 FG 200	Stainless Steel SS316
2.	Impeller	Glass filled Poly-propylene oxide (modified PPO)	Bronze IS 318 Gr LTB 2	Stainless Steel SS316
3.	Diffuser	Glass filled Poly-propylene oxide (modified PPO)	Cast Iron IS 210 FG 200	Glass filled Poly-propylene oxide (modified PPO)
4.	Pump shaft Coupling	SS 410	SS 410	SS 410
5.	Casing wear ring (if provided)	Bronze IS 318 Gr LTB 2,3,4 or 5	Bronze IS 318 Gr LTB 2,3,4,5	Bronze IS 318 Gr LTB 2,3,4,5
6.	Bush	Bronze IS 318 Gr LTB 2,3,4 or 5	Bronze IS 318 Gr LTB 2,3,4,5	Bronze IS 318 Gr LTB 2,3,4,5
7	Cable guard	SS304	SS304	SS304
	Motor			
8	Stator shell	Stainless Steel SS304	Stainless Steel SS304	Stainless Steel SS316
9	Shaft	SS 410	SS 410	SS 410
10	Bush	Bronze IS 318 Gr LTB 2,3,4 or 5	Bronze IS 318 Gr LTB 2,3,4,5	Bronze IS 318 Gr LTB 2,3,4,5
11	Thrust assembly	SS420 & graphite carbon	SS420 & graphite carbon	SS420 & graphite carbon

TECHNICAL SPECIFICATIONS M&E

1) Submersible pump set

The pump shall conform to IS 14220: 1994 amended up to date.

The pump shall be submersible type directly coupled to submersible water filled electric motor with built in anti thrust bearing. The pump set shall be complete with suction strainer, anti-thrust streamlined non return valve and minimum 4 m submersible type copper conductor cable of suitable size.

2 pairs of suitable size 10 mm thick erection/supporting clamps and 1(one) set submersible cable connection kit shall be provided with each pump set as standard accessories. The cost shall be included in the pump cost.

Inlet passage of the suction casing shall be designed reduce entry losses and strainer shall be provided in suction casing to restrain large solids entering the pump. For submersible type cables, clamping arrangement and cable guard shall be provided on pump casing.

Each metallic impeller shall be dynamically balanced to Grade G 6.3 of IS 11723. The pump characteristic shall be non overloading type to ensure trouble free operation in the entire operating range.

The submersible motor shall conform to IS 9283. The electric motor shall be single/ three phase squirrel cage, water filled submersible type. The motor shall be suitable for operation on 220V (single ph)/ 415V (3 phase), 50 c/s electric supply with required RPM capable of delivering the rated output.

2) Material of Construction

The material of construction shall be suitable for application and site conditions. The alternative material of construction shall be as follows:

3) TESTING:

Each pump-motor set shall be factory tested at manufacturer's works as per I.S. 8034 to determine following characteristics covering the full operating range.

- (i) Head- Discharge curve
- (ii) Efficiency curve
- (iii) Dynamic balancing of rotor, impeller

4) CERTIFICATES:

Contractor shall furnish:

- Performance characteristic.
- Catalogue of pump set and details of pump and its motor.
- Manufacturing test certificate, Guarantee card and list of parts for the pump sets.
- Operation and maintenance manuals for the pump set.

TECHNICAL SPECIFICATIONS M&E

-Drawings showing cross sections of pumps, mounting arrangements, list of materials and necessary curves along with their offer.

In the event of any pump failing to meet the specified requirement of pump set it shall be modified and retested until the requirements are fulfilled. The inspections and testing of the pump set are at contractors cost. Engineers of the Corporation may witness the shop test.

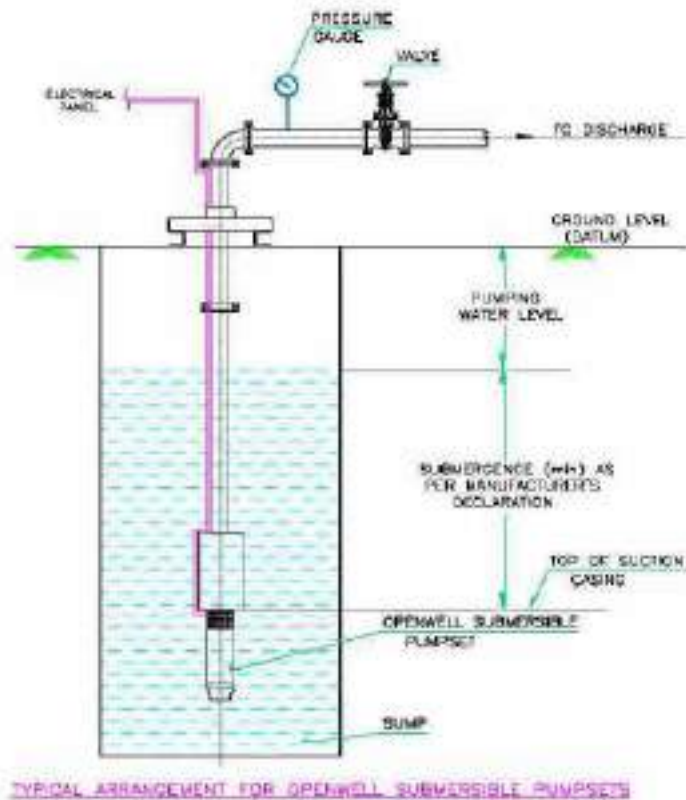

TECHNICAL SPECIFICATIONS M&E

SP-ME-TS-16 JET PUMPS:

These specifications are applicable for selection, supply and erection of centrifugal Jet pump sets of:

- (i) Motor rating : 1 HP to 2 HP
- (ii) Discharge capacity : 21 LPM to 55 LPM
- (iii) Head range : 9 m to 50 m

The pump rating shall be suitable to meet the operational requirement as per the site condition. Pump shall be horizontal/ vertical and jet arrangement as twin type/ Duplex type/ Packer type as per the site requirements. Site engineer before commencement of work shall approve the selection of the pump sets (as per guidelines indicated in IS 12699), pump installation and layout drawing.

1) Centrifugal Jet Pump

The pump shall conform to IS 12225: 1997 amended up to date.

The pumps used shall be of end suction centrifugal type. Constructional features of the centrifugal pump shall conform to IS 6595 (Part 1) or IS 9079. The pump set shall be complete with centrifugal pump, motor, Jet unit including nozzle and foot valve, strainer, pressure release valve along with suitable M.S structure foundation. Standard 6 m length each for suction and pressure pipe shall be included in the pump cost.

The pump shall be a combination of a centrifugal pump and jet unit. The jet shall be made up of suitable material to sustain both in slightly acidic or alkaline water. The jet shall be properly streamlined for good efficiency. The pump shall be of back pullout design for easy maintenance without disturbing pipe line and impeller shall be dynamically balanced.

2) Material of Construction

- (i) The material of construction shall be suitable for application and site conditions. The alternative material of construction shall be as follows:

Sr.	Component	Alternative- 1	Alternative- 2	Alternative- 3
	PUMP			
1.	Pump Casing	Cast Iron IS 210 FG 200	Cast Iron IS 210 FG 200	Stainless Steel SS316
2.	Impeller	Cast Iron IS 210 FG 200	Bronze IS 318 Gr LTB 2	Stainless Steel Gr 04Cr13/Gr 12Cr13/Gr 30Cr13 as per IS 6603
3.	Shaft	SS 410	SS 410	SS 410
4.	Shaft sleeve	Bronze IS 318 Gr LTB 2	Stainless Steel Gr 04Cr13/ Gr 12Cr13/ Gr 30Cr13 as per IS 6603	Stainless Steel Gr 04Cr13/ Gr 12Cr13/ Gr 30Cr13 as per IS 6603

TECHNICAL SPECIFICATIONS M&E

Sr.	Component	Alternative- 1	Alternative- 2	Alternative- 3
5.	Jet Pump (assembly) body	Cast Iron IS 210 FG 200	Cast Iron IS 210 FG 200	Bronze IS 318 Gr LTB 2/ Brass grade HTB 1 of IS 304
ACCESSORIES				
6.	Nozzle	Bronze IS 318 Gr LTB 2/ Brass grade HTB 1 of IS 304	PTFE	Stainless Steel Gr 04Cr13/ Gr 12Cr13/ Gr 30Cr13 as per IS 6603
7.	Venturi	Bronze IS 318 Gr LTB 2/ Brass grade HTB 1 of IS 304	PTFE	Stainless Steel Gr 04Cr13/ Gr 12Cr13/ Gr 30Cr13 as per IS 6603
8.	Foot valve	Bronze IS 318 Gr LTB 2/ Brass grade HTB 1 of IS 304	PTFE	Stainless Steel Gr 04Cr13/ Gr 12Cr13/ Gr 30Cr13 as per IS 6603
9.	Foot valve strainer	Cast Iron IS 210 FG 200	Polyethylene	Cast Iron IS 210 FG 200
PRESSURE REGULATING VALVE				
10.	Body	PTFE	PTFE	Bronze IS 318 Gr LTB 2/ Brass grade HTB of IS 304
11.	Diaphragm	Neoprene rubber/ nitrile rubber	Neoprene rubber/ nitrile rubber	Neoprene rubber/ nitrile rubber
12.	Valve seat	PTFE	PTFE	Bronze IS 318 Gr LTB 2

3) TESTING:

Each pump-motor set shall be factory tested at manufacturer's works as per guidelines for testing of I.S. 12225:1997.

4) CERTIFICATES:

Contractor shall furnish:

Performance characteristic. Catalogue of pump set and details of pump and its motor, manufacturing test certificate, Guarantee card and list of parts for the pump sets.

Operation and maintenance manuals for the pump set.

Drawings showing cross sections of pumps, mounting arrangements, list of materials and necessary curves along with their offer.

In the event of any pump failing to meet the specified requirement of pump set it shall be modified and retested until the requirements are fulfilled. The inspections and testing of the pump set are at contractors cost. Engineers of the Corporation may witness the shop test.

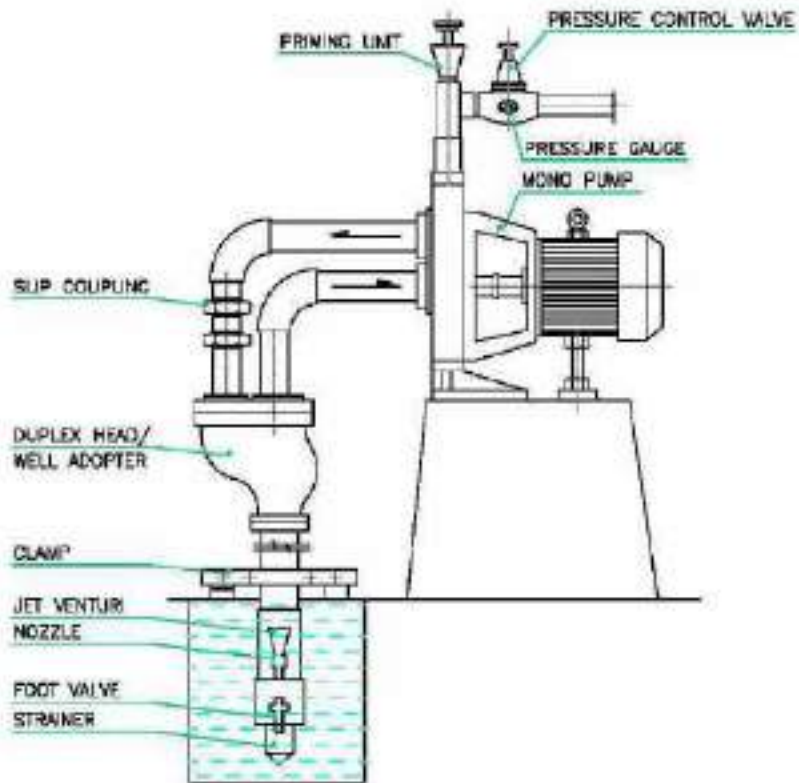

TYPICAL ARRANGEMENT FOR DUPLEX TYPE CENTRIFUGAL JET PUMP

TECHNICAL SPECIFICATIONS M&E

SP-ME-TS-17 SELF PRIMING PUMPS:

These specifications are applicable for selection, supply and erection of centrifugal self-priming pump sets of:

- (i) Motor rating : 1 HP to 10 HP
- (ii) Discharge capacity : 90 LPM to 420 LPM
- (iii) Head range : 6 m to 90 m

The pump rating shall be suitable to meet the operational requirement as per the site condition and suction lift required. Pump shall be horizontal/ vertical, single/ multi-stage as per the site conditions. Site engineer before commencement of work shall approve the selection of the pump, pump installation and layout drawing.

Centrifugal self-priming pump

The pump shall conform to IS 8418: 1999 amended up to date.

The pumps shall be of self-priming type and of mono block construction. The pumps shall be designed for large voltage fluctuations from 180 to 240V in case of single phase & from 300 to 440V in case of two or three phase. Pre packed (z z type) bearings shall be provided. A strainer of suitable mesh size shall be provided at the suction end pipe to prevent entrance of over sized solids. The suction lift of the pump shall be up to NPSH requirement of pump manufacturing.

The pump motor shall be totally enclosed and Class insulation class 'E', 'B' or 'F' as per application requirement. Stuffing box shall be provided with extra deep gland packing. Alternately Mechanical seal shall be provided as per requirements.

Each metallic impeller shall be dynamically balanced to Grade G 6.3 of IS 11723 (Part 1). In case the pump speed is less than 1500rpm and impeller diameter less than 250mm, the impeller may be statically balanced.

Inlet passages of the suction casing shall be streamlined to avoid eddies. The pump shall be capable to operate without overloading the prime mover in the specified head range. However the head range shall not be less than minimum +5% and minimum -15% of the rated duty point head up to 20 m. Above 20 m duty point head, the prime mover shall not overload between duty point and minimum -3 m head.

1) Material of Construction

The material of construction shall be suitable for application and site conditions. The alternative material of construction shall be as follows:

Sr.	Component	Alternative- 1	Alternative- 2	Alternative- 3
	PUMP			
1.	Pump Casing	Cast Iron IS 210 FG 200	Cast Iron IS 210 FG 200	Cast Iron IS 210 FG 200

TECHNICAL SPECIFICATIONS M&E

Sr.	Component	Alternative- 1	Alternative- 2	Alternative- 3
2.	Impeller	Cast Iron IS 210 FG 200	Stainless Steel Gr 04Cr13/Gr 12Cr13/Gr 30Cr13 as per IS 6603	Glass filled Polypropylene oxide (modified PPO)
3.	Casing wear ring (if provided)	Cast Iron IS 210 FG 200	Bronze IS 318 Gr LTB 2	Bronze IS 318 Gr LTB 2
4.	Shaft	SS 410	SS 410	SS 410
5.	Shaft sleeve	Bronze IS 318 Gr LTB 2	Stainless Steel Gr 04Cr13/Gr 12Cr13/Gr 30Cr13 as per IS 6603	Stainless Steel Gr 04Cr13/Gr 12Cr13/Gr 30Cr13 as per IS 6603

2) TESTING:

Each pump-motor set shall be factory tested at manufacturer's works as per I.S. 11346 to determine following characteristics covering the full operating range.

- (i) -Head- Discharge curve
- (ii) -Efficiency curve
- (iii) -Dynamic balancing of rotor, impeller

3) CERTIFICATES:

- (i) Contractor shall furnish:
- (ii) -Performance characteristic.
- (iii) -Catalogue of pump set and details of pump and its motor.
- (iv) -Manufacturing test certificate, Guarantee card and list of parts for the pump sets.
- (v) Operation and maintenance manuals for the pump set.
- (vi) Drawings showing cross sections of pumps, mounting arrangements, list of materials and necessary curves along with their offer.

In the event of any pump failing to meet the specified requirement of pump set it shall be modified and retested until the requirements are fulfilled. The inspections and testing of the pump set are at contractors cost. Engineers of the Corporation may witness the shop test.

Typical arrangement of centrifugal self-priming pump sets is presented below:



Self Priming Pumps

TECHNICAL SPECIFICATIONS M&E

SP-ME-TS-18 SUBMERSIBLE PUMP SET (BORE WELL)

These specifications are applicable for selection, supply and erection of submersible bore-well pump sets of:

- (i) Motor rating : 0.75 HP to 10 HP
- (ii) Discharge capacity : 900 LPM to 120 LPM
- (iii) Head range : 15 m to 80 m
- (iv) Bore well pipe diameter : 100 mm and 150 mm (as specified)

The pump rating shall be suitable to meet the operational requirement as per the site condition and Bore well pipe diameter. Site engineer before commencement of work shall approve pump installation and layout drawing

1) Submersible pump

- (i) The pump shall conform to IS 8034: 2000 amended up to date.
- (ii) The pump shall be submersible bore well type directly coupled to submersible water filled electric motor with built in anti thrust bearing. The pump set shall be complete with suction strainer, anti-thrust streamlined non return valve and minimum 4 m submersible type copper conductor cable of suitable size.
- (iii) 2 pairs of suitable size 10 mm thick erection/supporting clamps and 1(one) set submersible cable connection kit shall be provided with each pump set as standard accessories. The cost shall be included in the pump cost.
- (iv) Inlet passage of the suction casing shall be designed reduce entry losses and strainer shall be provided in suction casing to restrain large solids entering the pump. For submersible type cables, clamping arrangement and cable guard shall be provided on pump casing.
- (v) Each metallic impeller shall be dynamically balanced to Grade G 6.3 of IS 11723. The plastic or sheet metal impellers need not be balanced.
- (vi) The pump characteristic shall be non overloading type to ensure trouble free operation in the entire operating range.

2) Electric Motor

The submersible motor shall conform to IS 9283. The electric motor shall be single/ three phase squirrel cage, water filled submersible type. The motor shall be suitable for operation on 220V (single ph)/ 415V (3 phase), 50 c/s electric supply with required RPM capable of delivering the rated output with

TECHNICAL SPECIFICATIONS M&E

- (i) The terminal voltage differing from its rated value by not more than +6% and - 15%
- (ii) The frequency differing from its rated value by not more than 3% or
- (iii) Any combination of i) and ii).

Motor shall be capable of running continuously at a B. H. P. (brake horse power) not less than 10% in excess of that absorbed by pump set under any operating conditions.

- (i) Starting current for the motor shall be limited to 6 times the full load current.
- (ii) Motor shall have minimum starting torque of 140% FLT and maximum starting torque 200% FLT. It shall have 100% FLT during running condition.
- (iii) Contractor shall submit the motor details including manufacturer's guarantee for efficiency and P.F. at full load, no load, 3/4 load, 1/2 load

3) Material of Construction

The material of construction shall be suitable for application and site conditions. The alternative material of construction shall be as follows:

Sr.	Component	Alternative- 1	Alternative- 2	Alternative- 3
	PUMP			
1.	Pump Casing, Diffuser chamber	Cast Iron IS 210 FG 200	Cast Iron IS 210 FG 200	Stainless Steel SS316
2.	Impeller	Glass filled Polypropylene oxide (modified PPO)	Bronze IS 318 Gr LTB 2	Stainless Steel SS316
3.	Diffuser	Glass filled Polypropylene oxide (modified PPO)	Cast Iron IS 210 FG 200	Glass filled Polypropylene oxide (modified PPO)
4.	Pump shaft Coupling	SS 410	SS 410	SS 410
5.	Casing wear ring (if provided)	Bronze IS 318 Gr LTB 2,3,4 or 5	Bronze IS 318 Gr LTB 2,3,4,5	Bronze IS 318 Gr LTB 2,3,4,5
6.	Bush	Bronze IS 318 Gr LTB 2,3,4 or 5	Bronze IS 318 Gr LTB 2,3,4,5	Bronze IS 318 Gr LTB 2,3,4,5
	Cable guard	SS304	SS304	SS304
	Motor			

TECHNICAL SPECIFICATIONS M&E

Sr.	Component	Alternative- 1	Alternative- 2	Alternative- 3
	Stator shell	Stainless Steel SS304	Stainless Steel SS304	Stainless Steel SS316
	Shaft	SS 410	SS 410	SS 410
	Bush	Bronze IS 318 Gr LTB 2,3,4 or 5	Bronze IS 318 Gr LTB 2,3,4,5	Bronze IS 318 Gr LTB 2,3,4,5
	Thrust assembly	SS420 & graphite carbon	SS420 & graphite carbon	S420 & graphite carbon

4) TESTING:

Each pump-motor set shall be factory tested at manufacturer's works as per I.S. 8034 to determine following characteristics covering the full operating range.

- (i) Head- Discharge curve
- (ii) Efficiency curve
- (iii) Dynamic balancing of rotor, impeller

5) CERTIFICATES:

- (i) Contractor shall furnish:
- (ii) Performance characteristic.
- (iii) Catalogue of pump set and details of pump and its motor.
- (iv) Manufacturing test certificate, Guarantee card and list of parts for the pump sets.
- (v) Operation and maintenance manuals for the pump set.
- (vi) Drawings showing cross sections of pumps, mounting arrangements, list of materials and necessary curves along with their offer.

In the event of any pump failing to meet the specified requirement of pump set it shall be modified and retested until the requirements are fulfilled. The inspections and testing of the pump set are at contractors cost. Engineers of the Corporation may witness the shop test.

6) PLUMBING:

The work of plumbing shall be carried out for suction and delivery side of pumps with 'C' Class ERW G.I. pipe conforming to IS. 1239 complete with accessories such as reducer, unions, 90 deg. bends, couplings, nipples and tees etc. Plumbing shall be carried out in approved manner with leveling instrument. It shall be neat and systematic and in consultation with site Engineer. Unnecessary bend shall be avoided to reduce the losses. Rate of the same is included in the rate of plumbing.

TECHNICAL SPECIFICATIONS M&E

Pump delivery shall be 'C' class G.I. pipe with all accessories such as full opening Gate Valve. The Gate valve conforming to I.S. 778 and shall be connected to G.I. pipe line with union coupling (in some cases pipe line may have been already laid by civil contractors) for delivery of water to over head tanks, in the pump room. All the plumbing accessories shall be of preferably of same make as that of 'C' Class G.I.

Pipe. In case of erection of M.S. piping, flanges shall be welded to the pipes for interconnection of pipes, valves, and other plumbing accessories and specials etc. and shall be painted in approved manner. The rate of the same is included in the rate of plumbing. Alternatively wherever specified, flanged steel pipes shall be used. The rate of Supplying & Fixing of gate valves shall be taken from FME Schedule for Building Construction Works.

Typical arrangement of submersible bore well pump sets is presented below:

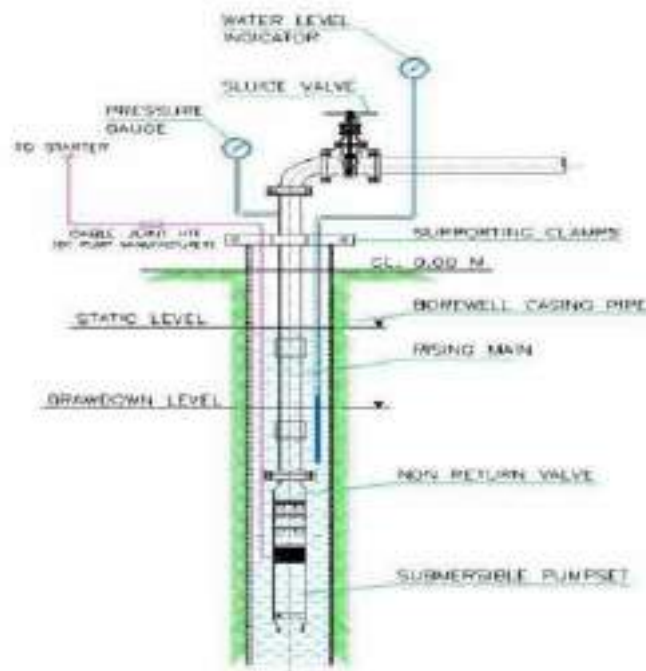

TECHNICAL SPECIFICATIONS M&E

SP-ME-TS-19 FITTINGS AND FIXTURES:

Unless otherwise specified fittings and fixtures shall be fixed on wall or ceiling using round block/ G.I. clamps. PVC junction box Recessed-mounting fixtures/tube light fittings shall be suspended from ceiling by M.S. Galvanized chain 1/4" dia. with M.S. hooks. Charges for same are included in the rate of items of fixtures.

Fluorescent Tube Light fixtures shall be suspended from ceiling by means of twin down suspension rods, fabricated from 16 SWG/2.0 sq.mm, 20 mm. M.S. conduits with ball socket flanges / G .I. clamps. as per instructions of site Engineer. Suspension rods shall be painted with two coats of white / grey / black enamel paint. Mounting height of the fixtures shall be as per instructions of site Engineer. Charges for such mounting arrangement shall be paid separately. All fittings and fixtures shall be provided earthing at particular earth point at ceiling rose.

In case of 'A' category Branded fluorescent fixtures the CRCA sheet shall be as per manufacturer's standard gauge but not less than 26 SWG/0.45mm.

1) Box type single/double fluorescent tube light fixture :

The fixture shall be made of CRCA sheet of 22 SWG/0.71mm. The box type channel shall be pretreated with zinc-chromate primer and painted with non-yellowing stove enameled paint or powder coated and a reflector preferably of suitable thick Aluminium Foil or good reflective metal. The fixture shall be suitable for 36 watt tubes and complete with polyester filled copper wound ballast, with P.F. Capacitor, pair of holders, starter holder 36 watt tubes and duly wired up to the connector block and condenser.

The fixture shall be connected to 3 plate ceiling rose with three core PVC to PVC insulated flexible wire of size 14/0.193 mm. or 16/0.20 mm copper conductors. The charges for all the accessories are included in the cost of the fixture.



2) Industrial type single/double fluorescent tube light fixture :

Same as above, but with reflector preferably of suitable thick Aluminium Foil or good reflective metal.

TECHNICAL SPECIFICATIONS M&E

3) Chalk board or displaying counter fixture:

Same as 2 above, but with Chalk board type reflector suitable for Chalk board or displaying counter.

4) Chalk Board Fitting 1 x 28W T5:

Body:

Decorative T5 Luminaire comprises of CRCA white Powder coated Channel and reflector. The reflector shall be of CRCA White Powder coated. Plastic End covers with T5 holders prewired with High Efficiency Electronic Ballast. Luminaire is suitable for mounting over Black / Chalk Boards.

Material Specification:

- (i) Channel : CRCA White Powder Coated.
- (ii) Reflector : CRCA White powder coated single directional.
- (iii) End cap : ABS Plastic.
- (iv) Wiring : PVC Insulated single strand copper wire.
- (v) Mains : 6Amp 3 way connector.
- (vi) Hardware : M.S. Zinc Plated & passivated.

Lamp Holder:

- (i) Rotar type suitable for T5 lamps

Electronic Ballast:

- (i) Passive power factor correction >0.98 Total Harmonic Distortion (THD) <10% Active Protection against Deactivated & fused lamps.
- (ii) Tested at 1.5 KV AC for insulation
Radio frequency Interference protection by passive filters Plastic Housing attractive Aesthetics.
- (iii) Operating Voltage range 160~270Vac 50/60Hz. Ease of wiring.

Installation:

- (i) Cable entry : Through conduit pipe suspension.
- (ii) Mounting : 2 Nos. 20mm Knockout & 2 nos. 6.5mm dia hole for suspension.
- (iii) Maintenance : Can be removed for accessories maintenance.



5) Street light (tube light) /PSL Fittings :

The Streetlight fixture shall be provided with polyester filled copper wound ballast or electronic ballast, starter, P.F. improvement capacitor pair of holders and duly wired up to connector block. Street light fluorescent fixture as above but with housing made from aluminium sheet with stove enameled grey and acrylic cover made from clear acrylic sheet (made from heat resistant material) and provided with 6 nos. of toggle clamps for fixing the acrylic cover on the canopy and rubber gasket.

The fixture shall be fixed on wall by means of app. 1.5 mtr. long 25 mm dia. 'B' class G.I. pipe, swan neck shape, duly painted in approved manner (One coat of red oxide and two coats of enamel paint i.e. grey/silver) with required hardware. Rate of same is included in the rate of fixture.

G. I. junction box of 16 SWG/1.6mm of size not less than 100 x 100 x 50 mm. with 10A heavy-duty connector shall be provided. Rate of same is not included in the rate of fixture.

The fixture shall be wired up to junction box by means of PVC/PVC insulated 3-core flexible cable with copper conductor of size 16/0.20 mm. in PVC flexible pipe of suitable size and length with proper clamping arrangement. Rate of same is included in the rate of fixture.



6) Strip light fluorescent fixtures :

The fixture shall be made of CRCA sheet steel of 22/24 SWG/0.71/0.55 mm pretreated with powder coated white shade paint. The fixture shall be suitable for 40/36 watts tubes, chokes, copper wound ballast or electronic ballast starter, P.F. improvement capacitor pair of holders and duly wired up to connector block. Fixtures shall be connected by means of PVC / PVC insulated 3 core flexible cable of size 16/0.20 mm or 14/0.193 mm.

The charges for above accessories are included in the cost of the fixture.



7) Recess mounting fluorescent fixtures:

The fixture shall consist of housing made of CRCA sheet steel of 22/24 swg/0.71/0.55 mm for accommodating all the electrical accessories. The louvers made of aluminium sheet for effective screening of light. Plate shall be provided in the fixture made of sheet aluminium to cover the electrical accessories. The fixtures shall be powder coated paint.

The fixture shall be complete white polyester filled copper choke, or electronic choke, power factor improvement capacitor, pair of holders, starter, 2 x 40/36 watts fluorescent tubes duly wired up to connector block & flexible 3 core copper cable from ceiling rose to fitting. The charges of all accessories and wires are included in the cost of fittings/fixture.



8) Modular recess type decorative fitting:

Same as 5 above, in door decorative recess mounting luminaries shall be provided with opal acrylic diffuser suitable for 4 tubes light of 18/20 W. This luminaries shall fit exactly in to modules of standard ceiling panel 2' x 2' allowing for easier installation.



Recessed Mounting



Surface Mounting



Suspended Mounting

9) Mounting provision shall be as follows:

Modular recess type decorative fitting resting on Al/MS ceiling of 305 module (exposed) ceiling or by using 4 Nos. of swing out brackets for concealed ceiling or by 19 mm. conduit suspension.

Recess type Decorative/Mirror Optics Fluorescent Fixture Suitable for 2 x 36 or 4 x 36 Watts fluorescent tubes:

Supply and installation of recess mounting fixture suitable for 2 or 4 x 36 Watts fluorescent tubes, copper wound ballast, starters, and pair of holders, P.F. improvement condenser and duly pre wired up to connector block. The fixture shall consist of

Channel made out of CRCA sheet not less than 0.63 mm. thick, pretreated, finished with powder coating

Dish type opal acrylic diffuser / Mirror assembly - made out of anodized high purity aluminium sheets for achieving high optical efficiency.

TECHNICAL SPECIFICATIONS M&E

Fixtures shall be connected by means of PVC / PVC insulated 3-core flexible cable of size 6/0.20 mm or 14/0.193 mm.

The charges for the above accessories are included in the cost of the fixture.

10) Ordinary lamp fixtures:

The ordinary lamp fixture shall be provided with angle holder/ pendent holder complete with 60W /100W GLS lamp and three core PVC flexible copper 14/0.193 or 16/0.20mm. wire if required as per site conditions and instructions of site engineer.

The ordinary lamp fixtures shall be provided with, app. 200 mm dia. White acrylic dome suspended from ceiling by means of aluminium rod app. 300/450 mm. length, complete with 40 watt GLS lamp.

The charges for all the accessories are included in the cost of fixture.



11) Duo-Flux fixtures:

Supplying and fixing Aluminium coated Duo Flux lamp fixture shall be provided with Aluminium coated reflector and complete with 500/1000 watt GLS lamp, lamp holder and 3 x 4.00 sq.mm. Copper conductor wires in PVC flexible pipe, suitable size, G. I. Junction box if required. The suitable mounting arrangement shall be provided as per instructions of site engineer. The charges for the above accessories are included in the cost of fixture. Cost of

G. I. Junction box shall be paid separately.

12) Bulk- head fixtures :

Supplying and fixing bulk-head type lamp fixture shall be provided with suitable for 60/100W incandescent lamp. It shall be made of aluminium casting pre-treated and painted with stove enameled paint white inside and grey outside. The fixture shall be provided with clear glass cover and wire mesh guard made of wire painted with stove enamelled grey paint and fitting shall be mounted on teak wood varnished board. The fixture shall be provided with neoprene rubber gasket, bayonets cap, lamp holder and GLS lamp of 60/100W. The fixture shall be connected to the ceiling rose by means of

TECHNICAL SPECIFICATIONS M&E

3 core PVC/PVC flexible wire with copper conductor of size 14/0.193 mm. or 16 / 0.20 mm.

The charges for the above accessories are included in the cost of the fixture.

13) Single/Double/CFL(9W / 11W) Fluorescent fixtures with Mirror optics :

Supply of fluorescent tube fixtures shall be suitable for TL5/TL8/TL12 fluorescent tubes with different Wattage. The fixtures shall be recess-mounting type. The fixture shall consist of -

- (i) Housing made out of CRCA sheet not less than 0.63 mm. thick duly pretreated and powder coated, stove enamelled.
- (ii) Pre wired accessories like copper wound ballast, starter seats, and starters, pair of holders, p. f. capacitors and tubelights.
- (iii) Mirror assembly - made out of anodized high purity aluminium sheets for achieving high optical efficiency or metalised plastic.
- (iv) Louvers shall be provided across the mirror to reduce luminaries glaze.
- (v) Three core PVC/PVC flexible wire of size 14/0.193 mm. of 16 / 0.20 mm. copper conductors.

The fixtures shall be indoor type, shall be fixed with a pair of down rods.

The charges for the above accessories are included in the cost of the fixture (except down rod).



14) Emergency tubelight fittings :

The Emergency tube light fittings shall work during normal 230V A.C. power supply. In the event of mains failure, the same fixture shall automatically get switched to integral battery supply.



Satisfactory working test shall be given for the emergency tube light fitting. The charges for all accessories are included in the cost of the fixture

15) Ceiling fans:

Supplying and fixing ceiling fan suitable to work on 230V/250V, 50 c/s A.C supply complete with aluminium blades duly painted with stove enamel white paint or any other available shade as instructed by site engineer, 2 nos. of canopies, down suspension rod, insulator shackle. The fan motor shall be capacitor start capacitor run and shall have double ball bearings. The ceiling fan shall be suspended from ceiling by providing 's' type hook of 10 mm M.S. round bars anchored to the reinforcement of the slab, making the patch work wherever required. In case of trusses the 's' type fan hook shall be fixed with suitable clamping arrangement and be mounted just above the adjacent fluorescent fixture to avoid the shadows. The fan shall be connected by three core PVC/PVC insulated sheathed flexible wire with copper conductors of size 16/0.20mm. The charges for fan hook are not included in the cost of the fan. Cost of the Electronic fan regulator is included in the cost of fan. Electronic fan regulator shall be provided for each fan.



TECHNICAL SPECIFICATIONS M&E

16) Exhaust fans:

Exhaust fan conforming to I.S.2312 of 1967 and of approved make and shall be suitable to work on 230V/ 250V, 50 c/s. A.C. single phase or 3 phase 415V A.C. supply. Single phase fan shall have capacitor start-run motor. The motor shall be totally enclosed type and provided with pressure die cast aluminium rotor mounted on ball bearings. The impeller shall be with four curved blades of deep drawn quality sheet steel fitted on robust aluminium die cast hub. The complete assembly shall be balanced to minimize vibration. The frame shall be fabricated from sheet steel. The fan and steel work shall be finished with dark grey stove enameled paint. The fan shall be installed on suitable size teak wood batten covered with wire mesh. Batten shall not be less than 50 X 40 mm. size.

The fan shall be installed in window frame or by taking suitable properly finished round hole in the wall. The fan shall be connected to supply outlet near the mounting complete with 3 pin socket or to three plate ceiling rose by means of suitable size three core PVC/PVC flexible wire of size 14/0.193 mm. of 16 / 0.20 mm. copper conductors.

The charges for the above work are included in the cost of fan.



17) Street light fixtures with HPSV Lamp :

Supply and installation of street light fixture with HPSV/HPMV lamp shall comprise of the following:

- (i) One piece die-cast aluminium body in circular shape finished with stove enameled paint white from inside and hammer grey from outside fixed with stainless steel toggles and perspex hinge.
- (ii) Control gear compartment housed with duly wired, copper wound ballast, capacitor, igniters, 15 Amps. porcelain terminal block for incoming mains, brass earthing terminal.
- (iii) Elegantly shaped high transparency acrylic cover fixed on body by-means of S.S. toggles and hinged with rigid closing.
- (iv) Neoprene Rubber gasket between lamp housing and acrylic cover. IP-55 protection class.
- (v) Pair of scientifically designed high purity anodized aluminium side reflectors in parabolic shape mounted on the bottom of lamp compartment.

TECHNICAL SPECIFICATIONS M&E

(vi) 125/250/400 watts HPSV / HPMV lamp:

(vii) The fitting shall be connected by 3 x 2.5 sq mm. PVC copper wire in PVC sleeves.

(viii) The fixture shall have suitable mounting arrangement on poles with extended portion of control gear and 2 Nos. of sturdy 'U' shaped clamps.

OR

The fixture shall have suitable mounting, arrangement on wall with swan neck type G.I. pipe up to control gear using 2 Nos. of Sturdy 'U' shaped clamps, complete with G.I. 16 SWG/1.62 mm junction box 100 mm. x 100 mm. x 75 mm. with fuse unit connector and 3 x2.5 sq.mm multi strand copper wires from fitting to junction box in PVC flexible pipe with gland.

The charges for the above accessories are included the cost of the fixture except Swan Neck type 'B' class G.I. pipe bracket.



18) Flood light fixtures:

Supplying and fixing flood light fixture shall be app. 470 mm. dia. anodized, brightened aluminium reflector with lamp holder housing. The fixture shall be provided with heat resistant glass cover to enclose the front side of the reflector. The special rubber gasket shall be securely fixed by an aluminium ring to make the fitting suitable for outdoor application. The housing shall have protection class of IP-65. The fitting shall be such that it could be rotated in horizontal and vertical planes and can be locked in any position by means of suitable size nut-bolt arrangement. The fitting shall be complete with 500/1000Watts GLS lamp. The gross weight of the fixture shall be not less than app. 5.8 Kg. The fittings shall be connected to the nearest point by 3 x 2.5 sq.mm. multi strand size copper wire in PVC flexible pipe and suitable size G.I. Junction Box.

The charges for the above accessories except G.I. junction box are included in the cost of the fixture.

TECHNICAL SPECIFICATIONS M&E

Flood light fixtures (with LED):

SITC of Direct light outdoor floodlight Colour temperature [K]: 3000]:

(R3-ME-4-1-i)

A. Supply, Installation, Testing and Commissioning of IP65 Direct light outdoor floodlight, designed to use warm white LED lamps, with flood optic. For wall-mounting with the special base. The luminaire consists of an optical assembly, upper cap and base for fixing to the wall. The optical assembly, upper cap and base are made of die-cast aluminium alloy coated with liquid acrylic paint (grey finish) or textured liquid (white finish) with a high level of resistance to weather and UV rays. Transparent tempered sodium - calcium safety glass with customised grey serigraphy, 4 mm thick, joined to the optical assembly with silicone. Adjustable fixing bracket made of painted aluminium; with a double nickel-plated brass PG11 cable gland, suitable for power cables \varnothing 6.5-11 mm. For electrical connection the product has a plastic box with three 2-pin quick-coupling terminals for cables with max. Cross-section 4 mm². Ambient operating from -20°C to +35°C. or equivalent.

SITC of IP65 Outdoor luminaire) Life Time LED 2: 74,000h - L80 - B10 (Ta 40°C)

(R3-ME-4-1-j)

B. Supply, Installation, Testing and Commissioning of IP65 Outdoor Direct light outdoor wall-mounted luminaire, designed to use warm white LED lamps, with wideflood optic. For wall-mounting with the special base. The luminaire consists of an optical assembly, upper cap and base for fixing to the wall. The optical assembly, upper cap and base are made of die-cast aluminium alloy coated with liquid acrylic paint (grey finish) or textured liquid (white finish) with a high level of resistance to weather and UV rays. 100,000h - L80 - B10 (Ta 25°C) Life Time LED 2: 74,000h - L80 - B10 (Ta 40°C) Ballast losses [W]: 0 Lamp code: LED Number of lamps for optical assembly: 1 ZVEI Code: LED Number of optical assemblies: 1 Ambient operating

SITC of Outdoor Floodlight. (L.O.R.) [%]: 78 Beam angle [°]: 10° CRI: temperature [K]: 3000

(R3-ME-4-1-k)

C. Supply, Installation, Testing and Commissioning of IP65 Outdoor Direct light outdoor wall-mounted luminaire, designed to use warm white LED lamps, with wideflood optic. For wall-mounting with the special base. The luminaire consists of an optical assembly, upper cap and base for fixing to the wall. The optical assembly, upper cap and base are made of die-cast aluminium alloy coated with liquid acrylic paint (grey finish) or textured liquid (white finish) with a high level of resistance to weather and UV rays. Transparent tempered sodium - calcium safety glass with customised grey serigraphy, 4 mm thick, joined to the optical assembly with silicone. The adjustable fixing bracket is made of painted aluminium.

TECHNICAL SPECIFICATIONS M&E

SITC of Outdoor surface wall asymmetric distribution Bulkhead fixture CCT : 3000K (R3-ME-4-1-I)s

D. Supply, Installation, Testing and Commissioning of IP65 Outdoor Direct light outdoor wall-mounted luminaire, designed to use warm white LED lamps, with wideflood optic. For wall-mounting with the special base. The luminaire consists of an optical assembly, upper cap and base for fixing to the wall. The optical assembly, upper cap and base are made of die-cast aluminium alloy coated with liquid acrylic paint (grey finish) or textured liquid (white finish) with a high level of resistance to weather and UV rays. Transparent tempered sodium - calcium safety glass with customised grey serigraphy, 4 mm thick, joined to the optical assembly with silicone. The adjustable fixing bracket is made of painted aluminium.



19) Halogen Flood Light Fixtures:

Supplying and fixing halogen flood light fixture shall be suitable for indoor and outdoor application, complete with 500 W / 1000 W, halogen tungsten lamp. The housing of the fitting shall be made of cast aluminium to ensure the high corrosion resistance. The housing shall be provided with cooling fins for better heat dissipation. The fixture shall consist of set of high purity aluminium sheet reflector, electro-chemically brightened and anodized, pair of lamp holders pre-wired up to the terminal block and fixed on housing, the glass retaining frame made out of cast aluminium, front cover made of heat resistant toughened glass, mounting bracket made of MS hot dip galvanized and silicon rubber gasket to make the fixture water proof. The housing shall have protection class of IP-65. The fixture shall also consist of junction box with cover, terminal block, cable entry gland, earthing terminal etc. The gross weight of the fixture shall be not more than app. 6.6 Kg. The fixture shall be connected to nearest supply point by means of 3 x 2.5 sq. mm. multi strands. Copper wires in PVC flexible pipe & suitable size G.I. Junction Box etc.

The charges for the above accessories except G.I. junction box are included in the cost of the fixture. Halogen flood light fixture for indoor application:

Supply & installation of flood light luminaries suitable for indoor application and complete with 500 W / 1000 W halogen lamps as above.



20) PL Luminaire (Recess Mounting):

Recess mounting fixture with mirror optics shall be suitable for use with 1 x PL-S 9 Watt / 11 Watt or 2 x PL-S 9 Watt / 11 Watt compact fluorescent lamps. The luminaires shall be mounted with the help of appropriate swing out brackets on ceiling or on unspecified ceilings.

The luminaires shall have housing made of mild steel, painted white. A mirror system shall be fixed into the housing for directing light on to the working plane. The optical system shall have a set of transverse louvers for limiting glare.

The fixture shall be complete with required number of PL-S 9 Watt or PL-S 11 Watt Lamps, lamp holders, connector block, universal copper wound ballast, earthing terminal etc. The PLS 9 W / 11 W lamp shall be complete with built in capacitor and specially integrated glow switch starter for instant starting characteristics or electronics ballast. The fixture shall be prewired with copper conductor for efficient functioning.

The charges for all the items and accessories are included in the cost of fixture.



TECHNICAL SPECIFICATIONS M&E

21) PL Luminaries (Surface Mounted):

Surface mounted luminaries shall be suitable for use with 1 or 2 x PLS, 9 W compact fluorescent lamps. The luminaries shall comprise of housing made of mild steel, painted white. The housing shall accommodate the copper wound ballast, lamp holder, and connector

block and earthing terminal. An acrylic cover (clear or opal) shall be fitted to curb direct glare from the lamp. The fixtures shall be complete with required number of PLS 9 W lamps, holder etc. The PLS 9 W lamp shall be complete with built in capacitor and specially integrated glow switch starter for instant starting characteristics. The fixture shall be prewired with copper conductor for efficient functioning. The necessary mounting arrangement shall be provided as per site requirements.

The charges for all the items and accessories are included in the cost of fixture.



22) Recessed down light:

Recessed down light fixture suitable to use with 1 x PL-S 9W compact fluorescent lamp. The luminaries shall be scientifically designed highly polished & with anodized aluminium reflector provides precise light control with optimum light utilization leading to substantial savings in light energy cost and excellent ambient conditions. Reflector is fitted into the frame with quick fix mounting arrangement. The frame is fabricated from C.R.C.A. sheet and painted white. Three nos. of retaining clips facilitate mounting in false ceiling. A gearbox with copper wound ballast shall be mounted on top of the luminaries. The fixture shall be complete with 1 x PL-S 9W/11W/18W compact fluorescent lamp, lamp holder etc. pre-wired properly with copper wire. The PLS-9W lamp shall be complete with built in capacitor and specially integrated glow switch starter for instant starting characteristics. Fixtures shall be connected by means of PVC / PVC insulated 3 core flexible cable of size 16/0.20 mm .

The charges for all the items and accessories are included in the cost of fixture.

TECHNICAL SPECIFICATIONS M&E



23) Industrial high bay / low bay / medium bay / luminaries:

Indoor industrial luminaries shall be suitable for SON Type 150 W / 250 W / 400 W high pressure Sodium Vapour Lamp or HPMV 250 W/ 400 W (high pressure mercury vapour lamp). The luminaries shall be suspended through an eye bolt. The luminaries shall comprise of-

- (i) A housing made from die cast aluminium (L M6) with low copper content offering excellent corrosion resistance, painted black and lamp holder.
- (ii) An eye bolt of app. 30 mm. inside diameter for suspension.
- (iii) Anodized aluminium reflector.
- (iv) Control gear box consisting of copper wound ballast electronic igniter, capacitor etc. of appropriate rating.
- (v) Sodium vapour / mercury vapour lamp of required rating.

The fixture shall be pre wired with 3 x 2.5 sq. mm. copper wire conductor properly. Suitable mounting arrangement with M.S. extension rod shall be provided as per site conditions. Extension rod shall be painted in an approved manner.

The charges for all the items and accessories are including in the cost of fixture.



24) Post Top Lantern with 70 Watt HPSV Lamp:

Supply and installation of Post Top Lantern fixture suitable for 70-Watts HPSV Lamp shall be complete with 70 Watts HPSV Lamp, spun aluminium alloy housing for ballast, porcelain holder mounted on housing heavy duty copper wound ballast,

TECHNICAL SPECIFICATIONS M&E

electronic igniter, p. f. improvement condenser, porcelain connector duly wired by copper conductors, pole mounting piece made out of cast aluminium and suitable for 65 mm. OD pipe. Necessary 'C' class G.I. Pipe Socket shall be fabricated on pole for fixing the fitting. The fixture shall have a cast aluminium spigot for corrosion free performance and shall be provided with bowl moulded diamond shape / double conical / ellipsoidal / spherical HDP cover for insect free performance without ingress of water. Fitting shall be connected with 3 x 2.5 sq.mm. Copper Wire up to pole junction box in PVC sleeve. The charges for the above accessories are included in the cost of the fixture.



25) Storage type Water Heaters:

Scope of work includes supply, installation and testing of horizontal/vertical, powder coated, storage type water heater suitable for wall/floor mounting of specified capacity, suitable to work on 230/250V single phase AC supply, heating element of specified wattage, thermostat, control fusible plug, pilot lamp. Storage type water heater shall be of approved make with ISI mark and conforming to IS 2082 of latest addition.

Material:

- (i) Outer casing shall be corrosion proof powder coated made of mild steel. Colour of casing shall be as directed by Engineer – in-charge.
- (ii) Inner tank shall be of electrolytic copper (99% pure), properly fabricated, leak proof of specified capacity.
- (iii) Heating element shall be mineral filled /tubular/ copper cord and nickel plated and conforming to IS 4159 of specified wattage.
- (iv) Pilot lamp- A neon gas filled indicating lamp shows functioning of heating element along with thermostat and thermal cut off.

Resin bonded glass wool slab thermal insulation shall be provided between two casings of storage water heater.

A stem type snap action thermostat shall be provided, which shall cut off the electric supply automatically as per setting of temperature.

The heaters up to 3 liters capacity shall be mounted on HG GI brackets and those above 3 liters shall be mounted on suitable size angle iron framework with clamping arrangement. A separate earth conductor of suitable size shall be provided to the heater body and frame, bracket etc. The heater shall be connected to switch/power

TECHNICAL SPECIFICATIONS M&E

outlet by suitable size / as per manufacturer's standard PVC insulated copper wire / cable. Storage type water heater shall be connected to existing water line complete with all accessories, plumbing, valves etc.

The charges for the above accessories are included in the cost of the fixture

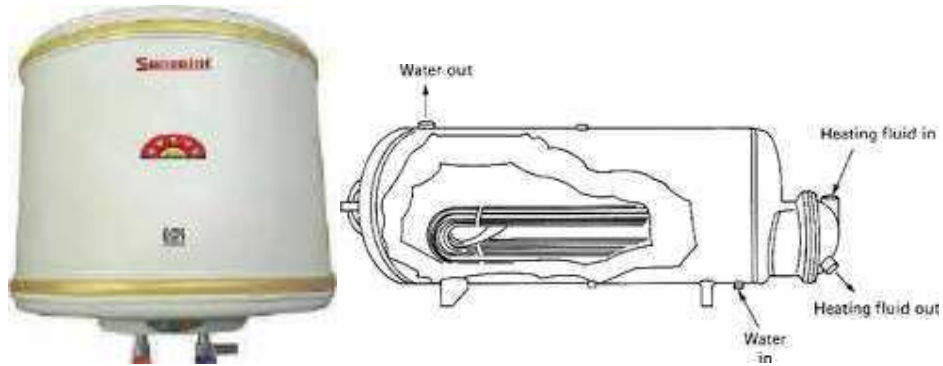

TECHNICAL SPECIFICATIONS M&E

SP-ME-TS-20 T-5 FIXTURES:

1) T-5 fitting THD< 33% Without Reflector

(Conforming to I.S. 10322 (Part 5 – sec.1) 1987).

This decorative T-5 luminaire comprises of M.S. powder coated housing with End cap & pre-wired with high efficiency electronic ballast. The luminaire is recommended for wall / ceiling mounting / suspending general indoor lighting purposes.

MATERIAL SPECIFICATION

- (i) Channel: M.S. white epoxy powder coated from inside & outside.
- (ii) Cover Plate M.S. white epoxy powder coated from inside & outside.
- (iii) Reflector: Inbuilt provision shall be made for fitting of reflector externally as per requirement.

- (iv) End Cap : ABS.
- (v) Internal Wiring: PVC insulated single strand copper wire.
- (vi) Mains Terminal: 3 way 5 amps suitable for terminating 2.5 sq. mm. incoming cable.
- (vii) Hardware: M.S. Zinc plated & passivated.
- (viii) Earthing: 1 No. inside suitable for 14 SWG earthing wire.

ACCESSORIES

- (i) Lamp Holder : Suitable for T – 5 , 28 Watt Lamp
- (ii) Ballast :
 - (i) Suitable for industrial use.
 - (ii) In-built protection against deactivated tube.
 - (iii) Metal housing /Engg. Plastic with slots on top cover for better thermal management.
 - (iv) Operating voltage range for ballast is 170-270V.
 - (v) Minimum supply voltage to ignite lamp is170 V.
 - (vi) Tested for 1.5 KV ac high voltage for insulation.
 - (vii) A separate earthing terminal is provided on input connector block.
 - (viii) Protected against main disturbances.
 - (ix) High Power Factor (> 0.95)
 - (x) Ease of wiring.
 - (xi) Tamper proof warranty seal.
 - (xii) Suitable for industrial use.
 - (xiii) Metal housing with slots on top cover for better thermal management.

- (iii) T-5 Lamp :
 - (i) Wattage - 28 Watt
 - (ii) Nom. Lumens - 2700 (lm)
 - (iii) Diameter - 16 mm
 - (iv) Max. Length - 1164 mm
 - (v) Colour - Cool Daylight (6500 K)

TECHNICAL SPECIFICATIONS M&E

- (vi) Lamp Life - 18000 burning hours (average).
- (vii) .Luminous Efficiency - 104 (lm / W) At 35 deg. C. ambient temperature.

INSTALLATION

- (i) Cable Entry: Through conduit suspension pipe.
- (ii) Mounting System: 2 Nos .- 20 mm dia knockout & 2 Nos. 6.5 mm dia hole for suspension.
- (iii) Maintenance: The cover can be removed for accessories maintenance.
- (iv) Protection : IP 20

2) T-5 fitting THD< 10% With Reflector

(Conforming to I.S. 10322 (Part 5 – sec.1) 1987).

This decorative T-5 luminaire comprises of M.S. powder coated housing with End cap & pre-wired with high efficiency electronic ballast. The bright anodized / powder coated reflector is provided for better optical efficiency. The luminaire is recommended for wall / ceiling mounting / suspending general indoor lighting purposes.

MATERIAL SPECIFICATION

- (i) Channel : M.S. white epoxy powder coated from inside & outside.
- (ii) Cover Plate : M.S. white epoxy powder coated from inside & outside.
- (iii) Reflector : Aluminium; bright anodised :bi-directional reflector >105mm wide.
- (iv) M.S. Powder Coated : bi-directional reflector > 85 mm wide.

- (v) End Cap: ABS.
- (vi) Internal Wiring: PVC insulated single strand copper wire.
- (vii) Mains Terminal: 3 way 5 amps suitable for terminating 2.5 sq. mm. incoming cable.

- (viii) Hardware: M.S. Zinc plated & passivated.
- (ix) Earthing: 1 No. inside suitable for 14 SWG earthing wire.



T-5 fitting with Reflector

ACCESSORIES

- (i) Lamp Holder: Suitable for T – 5 , 28 Watt Lamp

- (ii) 2) Ballast:
 - a. Suitable for industrial use.
 - b. . In-built protection against deactivated tube
 - c. Metal housing /Engg. Plastic with slots on top cover for better thermal management.
 - d. Operating voltage range for ballast is 170 -270 V.
 - e. Minimum supply voltage to ignite lamp is 170 V.
 - f. Tested for 1.5 KV ac high voltage for insulation
 - g. A separate earthing terminal is provided on the input connector block.
 - h. Protected against main disturbances.
 - i. High Power Factor (> 0.98), THD < 10 %
 - j. Ease of wiring
 - k. Tamper proof warranty seal.
 - l. Suitable for industrial use.
 - m. Metal housing with slots on top cover for better thermal management.

- (iii) T-5 Lamp: 1.
 - a) Wattage - 28 Watt
 - b) Nom. Lumens - 2700 (lm)
 - c) Diameter - 16 mm
 - d) Max. Length - 1164 mm
 - e) Colour - Cool Daylight (6500 K)
 - f) Lamp Life - 18000 burning hours (average).
 - g) Luminous Efficiency - 104 (lm / W) At 35 deg. C.ambient temperature.

TECHNICAL SPECIFICATIONS M&E

INSTALLATION

- (i) (Cable Entry: Through conduit suspension pipe.
- (ii) Mounting System: 2 Nos.- 20 mm dia knockout & 2 Nos. – 6.5 mm dia hole for suspension
- (iii) Maintenance : The cover can be removed for accessories maintenance.
- (iv) Protection: IP 20\

Ordinary fitting THD< 33% With Reflector

(Conforming to I.S. 10322 (Part 5 – sec.1) 1987).

This decorative T-5 luminaire comprises of M.S. powder coated housing with End cap & pre-wired with high efficiency electronic ballast. The bright anodized / powder coated reflector is provided for better optical efficiency. The luminaire is recommended for wall / ceiling mounting / suspending general indoor lighting purposes.

MATERIAL SPECIFICATION

- (i) Channel: M.S. white epoxy powder coated from inside & outside.
- (ii) Cover Plate: M.S. white epoxy powder coated from inside & outside.
- (iii) Reflector Aluminium; bright anodized: bi-directional reflector >105mm wide.
- (iv) **M.S. Powder Coated:** bi-directional reflector > 85 mm wide.
- (v) End Cap: ABS.
- (vi) Internal Wiring: PVC insulated single strand copper wire.
- (vii) Mains Terminal: 3 way 5 amps suitable for terminating 2.5 sq. mm. incoming cable.
- (viii) Hardware: M.S. Zinc plated & passivated.
- (ix) Earthing: 1 No. inside suitable for 14 SWG earthing wire.

ACCESSORIES

- (i) Lamp Holder: Suitable for T – 5 , 28 Watt Lamp
- (ii) Ballast:
 - a. Suitable for industrial use.
 - b. In-built protection against deactivated tube.
 - c. Metal housing / Engg. Plastic with slots on top cover for better thermal management.
 - d. Operating voltage range for ballast is 170-270 V.
 - e. Minimum supply voltage to ignite lamp is 170 V.
 - f. Tested for 1.5 KV ac high voltage for insulation.
 - g. A separate earthing terminal is provided on the input connector block.
 - h. Protected against main disturbances.
 - i. High Power Factor (> 0.95) , THD < 33 %

TECHNICAL SPECIFICATIONS M&E

- j. Ease of wiring.
 - k. Tamper proof warranty seal.
 - l. Suitable for industrial use.
 - m. Metal housing with slots on top cover for better thermal management.
- (iii) T-5 Lamp
- a. Wattage - 28 Watt
 - b. Nom. Lumens - 2700 (lm)
 - c. Diameter - 16 mm

INSTALLATION

- (i) Cable Entry: Through conduit suspension pipe.
- (ii) Mounting System : 2 Nos.- 20 mm dia knockout & 2 Nos. – 6.5 mm dia hole for suspension.
- (iii) Maintenance: The cover can be removed for accessories maintenance.
- (iv) Protection : IP 20

3) Ordinary fitting THD< 10% Without Reflector

(Conforming to I.S. 10322 (Part 5 – sec.1) 1987)

This decorative T-5 luminaire comprises of M.S. powder coated housing with End cap & pre-wired with high efficiency electronic ballast. The luminaire is recommended for wall / ceiling mounting / suspending general indoor lighting purposes.

MATERIAL SPECIFICATION

- (i) Channel: M.S. white epoxy powder coated from inside & outside.
- (ii) Cover Plate: M.S. white epoxy powder coated from inside & outside.
- (iii) Reflector: Inbuilt provision shall be made for fitting of reflector externally as per requirement.
- (iv) End Cap: ABS.
- (v) Internal Wiring: PVC insulated single strand copper wire.
- (vi) Mains Terminal: 3 way 5 amps suitable for terminating 2.5 sq. mm. incoming cable.
- (vii) Hardware: M.S. Zinc plated & passivated.
- (viii) Earthing: 1 No. inside suitable for 14 SWG earthing wire.

ACCESSORIES

- 1. Lamp Holder: Suitable for T – 5 , 28 Watt Lamp
- 2. Ballast:
 - a. Suitable for industrial use

TECHNICAL SPECIFICATIONS M&E

- b. . In-built protection against deactivated tube.
- 3. Metal housing / Engg. Plastic with slots on top cover for better thermal management.
 - a. Operating voltage range for ballast is 170 -270 V.
 - b. Minimum supply voltage to ignite lamp is 170V.
 - c. Tested for 1.5 KV ac high voltage for insulation.
 - d. 7. A separate earthing terminal is provided on the input
 - e. Connector block
 - f. 8. Protected against main disturbances.
 - g. High Power Factor (**> 0.98**).**THD < 10 %**
 - h. Ease of wiring.
 - i. Tamper proof warranty seal.
 - j. Suitable for industrial use.
 - k. Metal housing with slots on top cover for better management.
- 4. T-5 Lamp:
 - a. Wattage -28 Watt
 - b. Nom. Lumens - 2700 (lm)
 - c. Diameter - 16 mm
 - d. Max. Length - 1164 mm
 - e. Colour - Cool Daylight (6500 K)
 - f. Lamp Life - 18000 burning hours (average).
 - g. .Luminous Efficiency - 104 (lm / W) At 35 deg. C. ambient temperature.

INSTALLATION

- (i) Cable Entry : Through conduit suspension pipe.
- (ii) Mounting System : 2 Nos.- 20 mm dia knockout & 2 Nos. – 6.5 mm dia hole for suspension.
- (iii) Maintenance : The cover can be removed for accessories maintenance.
- (iv) Protection : IP 20

4) Commercial Recessed Mirror Optics Luminaire for T-5 Lamps.

(Conforming to I.S. 10322 (Part 5 – sec.1) 1987).

This decorative Commercial Recessed Mirror Optics Luminaire for T-5 lamps luminaire comprises of C.R.C.A M.S. housing with white epoxy powder coated finish .Pre-wired with high efficiency electronic ballast specially designed for T 5 lamp. Suitable for Offices, Commercial premises, Control rooms.

MATERIAL SPECIFICATION

- (i) Housing: CRCA M.S. white epoxy powder coated finish. The perforated CRCA MS epoxy powder coated panels separating the

TECHNICAL SPECIFICATIONS M&E

lamp compartment to cover the ballast assembly and improve aesthetics.

- (ii) Reflector: Double parabolic bright anodized high efficiency aluminium reflector. The double scalloped cross louvers with closed back ensures no light is trapped and conform to specifications for glare free illumination. High reflectivity aluminium reflector ensures iridescence free optics.
- (iii) End Cap: T 5 Lamp holders at both ends concealed by aluminium reflector cap highlighting superior design practices.
- (iv) Internal Wiring : PVC insulated single strand copper wire.
- (v) Mains Terminal : 3 way 5 amps suitable for terminating 2.5 sq. mm. incoming cable.
- (vi) Hardware : M.S. Zinc plated & passivated.
- (vii) Earthing : 1 No. inside suitable for 14 SWG earthing wire.

ACCESSORIES

Lamp Holder : Suitable for T – 5 , 28 Watt Lamps.

Ballast :

- (i) Suitable for industrial use.
- (ii) In-built protection against deactivated tube
- (iii) Metal housing with slots on top cover for better thermal management.
- (iv) . Operating voltage range for ballast is 170 -270 V.
- (v) . Minimum supply voltage to ignite lamp is 170 V.
- (vi) . Tested for 1.5 KV ac high voltage for insulation.
- (vii) A separate earthing terminal is provided on the input connector block.
- (viii) Protected against main disturbances.
- (ix) High Power Factor (> 0.95), THD < 33 %
- (x) Ease of wiring
- (xi) Tamper proof warranty seal.
- (xii) Suitable for industrial use.
- (xiii) Metal housing with slots on top cover for better thermal management.

T-5 Lamp :

- Wattage - 28 Watt
- Nom. Lumens - 2700 (lm)
- .Diameter - 16 mm
- Max. Length - 1164 mm
- Colour - Cool Daylight (6500 K)
- Lamp Life - 18000 burning hours (average).
- Luminous Efficiency - 104 (lm / W) At 35 deg. C. ambient temperature.

INSTALLATION

- Cable Entry : Through conduit suspension pipe.

TECHNICAL SPECIFICATIONS M&E

- Mounting System : 4 Nos. – 6.5 mm dia hole for conduit suspension.
- Maintenance : Mirror assembly held securely to the housing by simple spring loaded locking & clips for ease of maintenance.
- Protection : IP 20



T-5 fitting with Reflector

SP-ME-TS-20A LED FIXTURES

Outdoor LED Fixtures

1 Street Lights fittings

- a) LED streetlight with integrated driver of the same make having a minimum system efficacy of 90 lumen/watt supported with LM79 report .
- b) Suitable for Pole mounting. Prewired with high efficiency LED Driver .
- c) The luminaire should have cool white colour temperature (CCT>5000K) and a CRI>70. The luminaire shall meet IP65 rating with THD<20% & Pf>0.9.
- d) The luminaire housing should be made of pressure die cast aluminium.
- e) Heat sink should be part of the luminaire itself in the form of heat dissipating fins of high pressure die cast aluminum. External heat sink should not be glued or pasted to the fixture.
- f) External heat sink should not be glued or pasted to the fixture. Only high power single die ceramic based LED modules should be recommended with wattage 1-3W. Multi die epoxy based low power LEDs should not be used. Lens should be provided for each LED Make of LED : CREE/Lumileds/Nichia .
- g) The driver should be isolated type for protecting the LED Boards from abnormalities. Approved makes of Driver :Xitanium/Osram/Schreder



Street Lights fittings

2 SITC Metal Halide fixtures

LED streetlight with integrated driver of the same make having a minimum system efficacy of 90 lumen/watt supported with LM79 report . The luminaire shall have rated system lifetime of 50,000 burning hours at L70. The luminaire should have cool white colour temperature The luminaire shall meet IP65 rating The luminaire housing should be made of pressure die cast aluminum with heat resistant glass cover to enclose the front side of the reflector. The fitting shall be such that it could be rotated in horizontal and vertical planes and can be locked in any position by means of suitable size nut-bolt arrangement



3 Post top Lantern/ Handi type

Minimum system efficacy of 100 lumen/watt supported with LM79 report . The luminaire shall have rated system lifetime of 50,000 burning hours at L70. The luminaire should have cool white colour temperature The luminaire shall meet IP66 rating The luminaire housing should be made of pressure die cast aluminum .



4 Highbay luminaries

1. LED Highbay for 150 W with a minimum system efficacy of 105 lm/W. The luminaire shall have a rated system lifetime of 50,000 burning hours at L70. The luminaire should have a color temperature of 6500K and CRI > 80. The luminaire shall meet IP65 rating with THD < 20% and PF > 0.95. The luminaire housing should made of High Pressure die cast Aluminium with tempered glass and offering wide beam optics with 2*50 degree Rotational symmetry beam (for low ceiling heights & general lighting). The total power consumption should not exceed 138W (including driver).

2. LED Highbay for 210 W with a minimum system efficacy of 105 lm/W. The luminaire shall have a rated system lifetime of 50,000 burning hours at L70. The luminaire should have a color temperature of 6500K and CRI > 80. The luminaire shall meet IP65 rating with THD < 20% and PF > 0.95. The luminaire housing should made of High Pressure die cast Aluminium with tempered glass and offering wide beam optics with 2*50 degree Rotational symmetry beam (for low ceiling heights & general lighting). The total power consumption should not exceed 225W (including driver).

TECHNICAL SPECIFICATIONS M&E



5 LED Low Bay luminaires:-

LED Highbay with minimum system efficacy of 105 lm/W. The luminaire shall have a rated system lifetime of 50,000 burning hours at L70. The luminaire shall meet IP65 rating . The luminaire housing should made of High Pressure die cast Aluminium with tempered glass and offering wide beam optics.



6 Garden Light Luminaire Bollard Type:

With minimum system efficacy of 80 lm/W. The luminaire shall have a rated system lifetime of 50,000 burning hours at L70. The luminaire shall meet IP65 rating



7 Gate post

Fitting with minimum system efficacy of 80 lm/W. The luminaire shall have a rated system lifetime of 50,000 burning hours at L70. The luminaire shall meet IP65 rating

TECHNICAL SPECIFICATIONS M&E



INDOOR LED FIXTURES:

8 Downlighter/Wall mounted LED

For up to 8 W LED Recessed Downlighter with a minimum system efficacy of 80 lm/W and for above 8W LED Recessed Downlighter with a minimum system efficacy of 100 lm/W The luminaire shall have a rated system lifetime of min 40,000 burning hours at L70. The luminaire should have a color temperature of 6500K and CRI>70. The luminaire shall meet IP20 rating with THD<10% and PF > 0.9. The luminaire housing should made of pressure die cast aluminium with a high efficiency diffuser. The driver should be integrated and of the same make as the luminaire



9 LED Square Recessed Downlighter:

For up to 8 W LED Recessed Downlighter with a minimum system efficacy of 80 lm/W and for above 8W LED Recessed Downlighter with a minimum system efficacy of 100 lm/W The luminaire shall have a rated system lifetime of min 30,000 burning hours at L70. The luminaire should have a color temperature of 6500K and CRI>70. The luminaire shall meet IP20 rating with THD<20% and PF > 0.9. . Up to 24 w -The luminaire housing should made of plastic with a polycarbonate reflector and a high quality diffuser. For 36 W and 45 W-The luminaire housing should made of powder coated metallic CRCA with high efficiency opal diffuser. The driver should be integrated and of the same make as the luminaire.

9 a. Supply, Installation, Testing and Commissioning of Recessed luminaire applicable to the floor or ground, designed for fitting monochrome white LED sources, for illumination, fixed

TECHNICAL SPECIFICATIONS M&E

optic, with incorporated electronic control gear. The round frame has a diameter D=144 mm; the body and frame are made of AISI 304 stainless steel with sodium-calcium extra clear glass, thickness 12mm. Stainless steel body coated with black paint. The luminaire is fixed to the outer casing by means of two TORX-type screws and appropriate retention seals that ensure proper anchoring. Inclusive of LED circuit, OPTI BEAM aluminium reflector and black plastic cover. The product is wired using an A2 stainless steel cable gland, with type-H07RNF 2x1 mm² outgoing power cable (L=1200 mm)The outer casing for installation can be ordered separately from the plastic optical assembly. Differential mode or equivalent



10 Tubelight fixtures:

a) 18W LED Tube with a minimum system efficacy of 110 lm/W. The luminaire shall have a rated system lifetime of 50,000 burning hours at L70. The luminaire should have a color temperature of 6500K and CRI>80. The luminaire shall meet IP20 rating with THD < 10% and PF > 0.95. The luminaire housing should be made of white powder coated CRCA sheet steel.

b) 2*18W LED Tube with a minimum system efficacy of 110 lm/W. The luminaire shall have a rated system lifetime of 50,000 burning hours at L70. The luminaire should have a color temperature of 6500K and CRI>80. The luminaire shall meet IP20 rating with THD < 10% and PF > 0.95. The luminaire housing should be made of white powder coated CRCA sheet steel.

Supply, Installation, Testing and Commissioning of IP67 flexible 24 V linear LED strip up to 7.5 m in length. Polyurethane encapsulation offering a premium water proof sealing, UV resistance, chemical stability against urban gases and protection against abrasion. White lower casing for higher efficiency (better light extraction). Delivered with 200 mm IP67 mini connectors on both ends. Constant Voltage LED strip with 62.5 mm and a small LED pitch of 8.93 mm the first choice for outdoor applications with a direct top view or indirect lighting with low construction depths – with perfectly homogeneous light.

Supply, Installation, Testing and Commissioning of For Steplight module, Luminaire for walkways designed to use high visual comfort LED lamps. Ceiling and wall-recessed installation. It consists of an optical assembly with an IP66 protection rating and an outer casing or wall-mounted base to be ordered separately. The optical assembly and base are made of aluminium alloy treated with powder paint, which provides a high level of resistance

TECHNICAL SPECIFICATIONS M&E

to weather and UV rays. Plastic closure guard at the rear of the optical assembly. Complete with plastic cable gland and outlet cable. Sodiumcalcium tempered satin finish safety glass. Luminaire with no visible screws and an anti-vandal system that uses an opening key to access the rear wiring compartment (supplied in the package). All external screws used are made of A2 stainless steel. Ambient operating emperature range: from -20°C to +35°C. (*) LED Current [mA]: 50 Control: PWM or equivalent

The LED shall be recessed mounted square shaped of size 150mmX150mm of 10W. The material of construction shall be aluminum with 10-12 LED. The LED light shall be provided with driver and light connection shall be white



11 Chalk Board fitting-

LED Tube with minimum system efficacy of 110 lm/W. The luminaire shall have a rated system lifetime of 50,000 burning hours at L70. The luminaire should have a color temperature of 6500K and CRI>80. The luminaire shall meet IP20 rating .The luminaire housing should made of white powder coated CRCA sheet steel. Luminiare is suitable for mounting over Black/ chalk boards.

12 Bulkhead Fixtures

With a minimum system efficacy of 60 lm/W. The luminaire shall have a rated system lifetime of 50,000 burning hours at L70. The luminaire should have a color temperature of 6500K and CRI > 70. The luminaire shall meet min IP54 rating and IK 09 rating with THD < 20% and PF > 0.9. The luminaire housing should made of High pressure die cast Aluminium with polycarbonate front diffuser



13 Spot Light :-

With a minimum system efficacy of 80 lm/W The luminaire shall have a rated system lifetime of min 20,000 burning hours at L70. The luminaire should have a color temperature of 6500K The luminaire shall meet IP20 rating. The luminaire housing should be made of plastic with a polycarbonate reflector and a high quality diffuser



14 Integral driver LED Steplight 4W :-

With a system lumen output of 40 lumens and a minimum system efficacy of 10 lm/W. The luminaire shall have a rated system lifetime of 25,000 burning hours at L70. The luminaire should have a color temperature of 4000K and CRI > 75. The luminaire shall meet IP67 rating with THD < 20% and PF > 0.9. The luminaire shall have polycarbonate diffuser. The total power consumption should not exceed 4W (including driver).



TECHNICAL SPECIFICATIONS M&E

SP-ME-TS-21 CORROSION PROOF STREET LIGHT LUMANAIRE

Luminaires shall be designed for multipurpose lighting utility like secondary Road street lighting, ceiling & wall mounted lighting and hazardous & corrosive area lighting. The luminaire provides excellent light distribution on all the sides and shall be very easy to maintain. High impact proof polycarbonate luminaire shall be designed to withstand arduous atmospheric conditions where luminaires are exposed to high humidity and corrosive vapours like chemical plants, Fertilizer & Food processing plants, Breweries, conveyors, Tunnels. Subways, Pedestrian Bridges, side roads, car parks, Petrol pumps, Residential areas, Loading areas, Building perimeters, security lighting, Coastal areas, etc.,

Luminaire shall be designed as energy saver, weather-proof, Dust proof, corrosion-proof and high impact proof against vandalism.

The Integral type fitting comprises of single piece UV resistant ABS/Poly-carbonate alloy (Bayer, Germany, ABSOLAC XT04 (P) grade) moulded housing in black/grey colour. A 22swg galvanised tray wired with heavy duty copper choke/Electronic ballast, lamp holder, etc, up to Plug in type terminal block is mounted on to housing with 4.3mm screws, ASS mounting clamp is provided for mounting the Luminaire on 32mm pipe along with P7 cable gland for 8 mm conduit. In case of surface mounting or suspension 4 nos S.S. Screws are provided on both the ends of the Luminaire.

A Specially designed electro brightened & anodised high purity aluminium parabolic reflector shall be provided on the tray for maximum distribution and appealing aesthetically. All accessories like lamp holder mounting, lamp support, Toggles, Hinges shall be moulded from UV resistant virgin glass filled nylon to withstand high temperature, vibrations and adverse conditions. A clear UV resistant poly carbonate bowl shall be hinged to the main housing body. A specially moulded one piece silicon rubber gasket fits into the groove of the housing and shall have unique lip and 6 no glass filled nylon toggles that click fits and 1 no 5/32 S.S. screw that seals the luminaire effectively rendering it dust-proof & Weather proof.

All hardware shall be corrosion resistant. IP Protection: IP 65

IS Specification: IS 10322 (Part 5 / section 1)



TECHNICAL SPECIFICATIONS M&E

SP-ME-TS-22 ENERGY SAVER CORROSION PROOF STREET LIGHT LUMINAIRE:

The Integral luminaire shall comprise of moulded ABS (engineering plastic) housing complete with control gear and all accessories mounted on a CRCA sheet steel tray with bright mirror finish reflector. A clear light stabilized acrylic cover held against neoprene gasket shall seal the luminaire effectively and render it weatherproof. The luminaire and all the hardware shall be corrosion resistant, and ensures maintenance free working.

- (i) Energy Efficient Street light fixture shall have following Special features :
- (ii) All electrical accessories such as electronic ballast, lamp holders shall be pre wired to a terminal block & mounted on a easily detachable gear plate.
- (iii) Hanging arrangement for acrylic bowl for ease of maintenance.
- (iv) Conformance to IP 65 protection.
- (v) Conformance to IS 10322 specification
- (vi) High power factor > 0.92

SP-ME-TS-23 ENERGY SAVER BULKHEAD LUMINAIRE:

The Energy Saver Bulkhead Luminaire shall be made of cast aluminium body pretreated and stove enameled paint, white inside and Grey outside. It shall comprise of polycarbonate housing in various colours duly wired with ballast and all accessories mounted on a CRCA sheet steel tray. A high impact clear prismatic heat & UV resistant polycarbonate diffuser fitted with EPDM gasket on to the housing. The luminaire shall be corrosion resistant, and ensures maintenance free working with protection class of at least IP 54. The fixture shall be provided rubber gasket B22 lamp holder suitable for CFL Energy saving retrofit lamps 5/8, 9/11, 15/20, or 23W.



TECHNICAL SPECIFICATIONS M&E

SP-ME-TS-24 ENERGY EFFICIENT STREET LIGHT LUMINAIRE FOR ROAD LIGHTING:

The luminaire housing shall comprise of one piece Aluminium Deep drawn body with clear acrylic cover. The luminaire shall have high purity Aluminium reflector and will consists of rubber gasket giving IP 65 protection confirming to IS 10322.

The luminaire shall be in use with 4 tubes of 14W (4 X 14W T5) or 24W (4 X 24W T5). The tubes shall run in individual electronics ballast having power factor appr. 0.98.

SP-ME-TS-25 RECESSED MOUNTED CFL LUMINAIRES - 36 WATT:

Recessed Mounted CFL Luminaries shall be aesthetic in appearance suitable for use with 2x18W or 3x12W compact Fluorescent lamps. The P.F. shall be minimum 0.88

Features

- (i) Housing shall be made of single piece powder coated CRCA sheet steel accommodating all electrical accessories pre-wired upto a terminal block.
- (ii) The perimeter of the luminaire shall be provided with perforations of 2 mm dia. With 3 mm orthocyclic pitch to add aesthetic appeal.
- (iii) It shall be Energy saving with super low watt loss ballast.
- (iv) A reflector assembly shall be made of metalised polystyrene louvers.

SP-ME-TS-26 RECESSED MOUNTED CFL LUMINAIRES LOW WATTAGE:

Recessed luminaries shall be suitable for use with PL-S 9 W/11W Compact Fluorescent lamps.

Features

- (i) Housing made of CRCA sheet steel, painted white, accommodating all electrical accessories pre-wired upto a terminal block
- (ii) A reflector assembly, made of high purity aluminium sheet, electrochemically brightened and anodized, fitted with painted aluminium lamellae.
- (iii) Stainless spring clips for fixing the reflector to the housing.

TECHNICAL SPECIFICATIONS M&E

SP-ME-TS-27 ELECTRONIC BALLAST:

The Electronic Ballast shall incorporate Short Circuit. Protection, de-activated Tube protection, no-Tube protection The Model must be Compact, Robust and it must have Wider Working voltage range: – 170 to 250 V, Total Harmonics Distortion level shall be less than 10 %.



SP-ME-TS-28 FAN'S ELECTRONIC REGULATOR:

The Electronic Regulator for ceiling fan shall be of Step type electronic circuit. The regulator shall be rated for minimum 100W.



SP-ME-TS-29 FLUORESCENT TUBE :- 28 W – T 5 (4FT.):

- (i) Input AC Voltage: 125 to 300 V, 50 Hz. Length of Tube: 4 Ft.
- (ii) Power consumption: 28 W +/- 1 W. Input Current: 125 to 150 mA,



TECHNICAL SPECIFICATIONS M&E

SP-ME-TS-30 WIRE GUARD FOR MH/STREET LIGHT/ CFL FITTINGS:

Wire guard to be used for the safety of fixture shall be made of 8 SWG SS wire. Wire mesh shall be designed such that illumination should not be affected. It shall be fixed with the proper clamping/fixing arrangement on the fixture.



SP-ME-TS-31 DIESEL GENERATING SET

D.G.Set shall comprise of:-

a) Engine: -

Four stroke cycle (air cooled up to 15 KVA and water cooled above 20 KVA), electric start, developing required BHP at 1500 RPM under NTP conditions. The engine shall be designed to run continuously, conforming to BS: 5514/ DIN-6271/IS 10001/IS 10002/ ISO – 3046. with an overload capacity of 10% for one hour in any 12 hours continuous under standard reference conditions. The diesel engine model shall be tested & certified for complying with CPCB norms. The engine shall be complete with standard accessories, spares and tools as detailed below:-

1. Radiator with fan.
2. Exhaust gas turbocharger.
3. Residential type silencer with required length of exhaust pipe.
4. Air cleaner.
5. Fuel lift pump.
6. Lube oil filter.
7. Fuel filter.
8. Heavy Duty dynamically balanced flywheel.
9. Electronic governor.
10. Starter with suitable capacity battery.
11. Battery charging unit of suitable capacity for equipments.
12. Engine control panel consisting of engine safety module with built in ON/OFF/Start key, Lube oil pressure switch gauge, battery charging voltmeter, hour meter, coolant temperature gauge controller for electronic governor.
13. Low Lube oil pressure, high coolant temperature, over speed shut down system.

TECHNICAL SPECIFICATIONS M&E

b) Alternator:-

The alternator shall be rated capacity at 0.8 power factor, 415 volts, 3 phase, 4 wire, 50 cycles/sec, 1500 rpm, self excited and self regulated, with brush less excitation. Band of voltage regulation shall be + 2.5% of rated voltage from no load to full load. Insulation class shall be "H". The alternator shall be conforming to BS:5000/IS 4722 and shall be designed to withstand tropical conditions. Required output shall be under NTP conditions.

c) Base Frame & Mounting Arrangement:-

The engine & the alternator shall be directly coupled to each other by means of couplings in order to form very compact arrangement. Cooling system & both these units shall be mounted on a rigid fabricated M.S. common base frame. The base frame of the diesel generating set shall be sturdy and fabricated/ welded construction out of M.S. channel iron base of suitable size for mounting the above engine & alternator. The base frame shall be suitably designed to simplify transportation, handling, slinging, E&C. This base frame shall be painted with anti corrosive epoxy paint. Noise level shall not exceed 75 dB as per CPCB norms of noise. A set of anti vibration pads shall be provided between base frame and engine alternator.

d) Battery:-

Suitable Dry type Batteries of Standard Make with leads and Terminals shall be part of the equipment. The pack shall be suitably positioned and modular withdraw able to ease of servicing. The Battery pack shall be minimum 180 AH

e) Fuel Tank:-

Fuel Tank should be located nearest to the DG set enclosure to ensure free flow of diesel. Suitable capacity of the fuel tank to run the set for about 12 hours with mounting bracket, level indicator, fuel inlet, fuel outlet, air vent, drain plug, inlet arrangement for direct filling and set of hoses for inlet & return.

f) Exhaust Piping:-

The exhaust piping shall be of suitable size and dimensions as per manufacturer's recommendations. The residential silencer shall be provided to maintain the noise level as specified. The exhaust piping shall be insulated with heat resistive material like asbestos, glass wool etc. and clamped/supported, mounted on wall/ floor by suitable size clamping arrangement. Outlet of exhaust shall be taken out from the structure as per site conditions and covered to protect from atmosphere effects like rain etc. shall be made good by plastering after completion of work. The material of piping shall be of approved make and quality (for indoor installations).

g) Acoustic Enclosure:

The enclosure shall be CPCB type approved soundproof enclosure. The enclosure shall be modular construction with hinge bolted structure to provide

TECHNICAL SPECIFICATIONS M&E

easy dismantling and reassembling. The DG set with enclosure shall undergo strict quality checks and testing to achieve high-end performance so that the offered DG set with enclosure enables reduction of sound and thus as per latest CPCB norms of noise at 1 mtr. distance under free condition should be 75 dB.

The Acoustic enclosure should be incorporated following:

- (i) The base plate fabricated out of suitable thickness sheet metal.
- (ii) The roof, sidewalls, integral partition and doors shall be sandwich design made out of good quality CRCA sheet steel.
- (iii) The Acoustic enclosure shall be naturally cooled to maintain approximate temperature difference with ambient air of 70C if required forced ventilation shall also be considered.
- (iv) The sound absorption material is selected from either glass wool/PU foam/ PVC foam of relevant thickness and density to have higher sound absorbing coefficient with low thermal conductivity to meet the performance.
- (v) The enclosure construction shall provide sufficient access for maintenance work.
- (vi) The control panel should be suitably mounted inside the DG set enclosure and enclosure door is provided with panel viewing window made from glass/ Acrylic and sealed with high quality Rubber gasket.
- (vii) The enclosure shall be complete with:
 - a) - Arrangement for power cable connection for load and mains supply.
 - b) - Integral- Residential Exhaust Silencer.
 - c) - Suction Louvers.
 - d) - Discharge Louvers.
 - e) - Open able & lockable doors with airtight, high quality rubber gasket.
 - f) Interior lighting arrangement with ON/OFF switch on control panel as per size of DG set.
 - g) Lifting arrangement.
 - h) The engine & AC Generator should be flexibly coupled, aligned and mounted with suitable Anti Vibration Mountings

TECHNICAL SPECIFICATIONS M&E

h) Installation of D.G. Set:-

R.C.C. Foundation: The D.G. set shall be installed on suitable R.C.C. foundation after preparing the excavation pit, R.C.C. foundation bed etc. by means of concrete of grade coarse M-20 as per IS: 456-and grade of steel Fe-415. The necessary rag foundation bolts of requisite size, length and dimensions shall be provided. The quantity of R.C.C. material shall be as per manufacturer's design. The R.C.C mixing will be in the proportion of 1:1.5:3 in standard manner

Erection of D.G. set: The base frame on which the engine and the alternator are mounted shall be tightened to rag bolts if required with proper levelling and alignment.

First fill of oil diesel initial battery charging, load trial, transportation / unloading of DG set is the responsibility of supplier.



TECHNICAL SPECIFICATIONS M&E

SP-ME-TS-32 AMF PANEL:

Control panel shall conform to IS: 2198. The panel shall be floor mounted type, totally enclosed with construction conforming to IP-56 type made of 16 SWG dust inhibited MS sheet of suitable size to accommodate accessories as specified with hinged doors and bottom gland plate. Panels shall be powder coated with epoxy after seven - tank pretreatment process. The panel shall be completely solid-state design, compact and neatly wired. Annunciation facility with alarm and indication windows for faults and tripping shall be provided wherever necessary. The panel shall comprise of :

- (i) MCCB suitably rated with standard accessories.
- (ii) Contactor of suitable rating.
- (iii) Neutral isolation contactor of suitable relays.
- (iv) Set of control fuses and auxiliary relays.
- (v) Set of tinned Copper busbars of suitable rating.
- (vi) Automatic battery charger circuit having variable input voltage from 180-230V but the constant output DC voltage, with ON/OFF switch, with ON indication, reverse polarity indication, DC battery charging ammeter.
- (vii) Microprocessor based AMF logic controller with following features:
 - (1) 3 Phase sensing of mains failure
 - (2) Impulse start of DG Set
 - (3) Off/Manual/Auto/Test selector switch.
 - (4) Sensing of mains voltage presence
 - (5) Engine idling/cooling.
 - (6) Mains metering on one common screen(three phase) by providing load manager.
 - (7) Digital Voltmeter.
 - (8) Digital Ammeter.
 - (9) Digital Frequency.
 - (10) Digital KW meter.
 - (11) Digital Power Factor meter.
 - (12) Digital Kwh meter.
 - (13) Digital Kvarth meter.



SP-ME-TS-33 REMOVAL AND REFIXING OF ELECTRICAL ACCESSORIES:

1) Removal :

The existing electrical accessories such as switch gears, point wiring, mains, sub mains, cables, fixtures, pumps, poles, panels etc. shall be removed without damaging the accessories, walls, ceilings etc. in neat manner with good workmanship. The holes/patches etc. shall be made good and painted to match surrounding surface. Dust and dirt sprayed due to work of removal/re fixing shall be removed and the premises shall be cleaned properly. The removed material shall be handed over to the contractor in as is and where is condition and they shall have to give rebate on it as offered while quoting. The removed material shall be taken away by the contractor at his own risk and cost.

2) Refixing :

Old electrical accessories such as switch gear, fixtures, cable etc. removed as above shall be refixed with new mounting accessories such as round blocks, ball sockets, screws, clamps, saddles, spacers etc. using old conduit pipes in approved manner with good workmanship. Holes, patches etc. occurred while carrying out this work shall be made good.

SP-ME-TS-34 PAINTING:

1. Painting of steel work:

All steel work shall undergo a process of degreasing, pickling in acid, cold rinsing, phosphatising, passivating and then sprayed with a high corrosion resistant primer. The primer shall be baked in an oven. The finishing treatment shall be by application of synthetic enamel or powder coated of approved shade.

2. Spray Painting:

The fan and fixtures shall be scrapped properly. Old paint shall be removed completely, and one coat of red oxide shall be applied and the dent if any shall be removed and filled with best quality putti. Finally, two coats of best quality approved shade of enamel paint or powder coating shall be applied in perfect manner.

The item of spray painting to steel cupboards, tables, water coolers, refrigerators and any other hospital articles shall be paid on surface area basis. The work of spray painting of such articles also includes the work of repairs involved such as repairs/replacement of the legs of the cupboards, bed side lockers, wheels of the chairs, locking arrangement, patch work by replacing 18 SWG/1.21 mm M.S sheet with proper welding etc.

3. White Washing:

White washing internally or externally to new or old surfaces in lime wash prepared from quick lime of best quality by adding blue and glue of approved quality in required quantities as directed including cleaning the walls, ceiling etc. with broom, coir and sand paper if necessary before applying the lime wash in two coats. The rate is inclusive of staging or scaffolding.

TECHNICAL SPECIFICATIONS M&E

The work of cleaning and white washing shall be supervised by the competent representative of the contract to ensure that no electrical equipment / switch gear / panel / Light fittings/Fans/cables and wires are damaged during the work.

Panels and switchgear shall be properly covered with insulating material to avoid accidental contact of human being and discoloring of the panel/switch gear.

TECHNICAL SPECIFICATIONS M&E

SP-ME-TS-35 REPAIRS / REWINDING OF INDUCTION MOTORS / FANS / PUMPS ETC:

Repairs, rewinding and overhauling of squirrel cage induction motors and fans as per following specifications.

- a) To remove existing winding without damaging the slots, body etc. of motor/fan
- b) To clean winding slots by polish paper and petrol.
- c) To clean rotor by petrol.
- d) To rewind the motor by using same size of electrolyte copper wire and 'B' Class of insulation.
- e) To varnish the winding by applying air-dry varnish with heating and baking up to required temperature and time. The motor shall be then assembled.
- f) The motor/fan shall be spray painted as per GR-12 above. The color shade shall be as per the instructions of site engineer. Miscellaneous items such as cotter pin, check nut etc. shall be replaced (condenser shall be replaced wherever necessary).

Any other accessories such as fasteners, ventilation fan etc. shall be replaced as specified. To replace ball/roller/thrust bearing SKF make only to be used

Fans and motors shall be taken away by the contractor to their workshop and delivered to office duly repaired with their own conveyance arrangement.

Pumps shall be repaired without disconnecting the pump casing from suction/delivery piping.

TECHNICAL SPECIFICATIONS M&E

SP-ME-TS-36 REPAIRS & PAINTING TO STEEL FURNITURES:

Cot, bedside locker, steel cupboard shall be repaired and spray-painted as per TS 32. Colour shade shall be applied as per instructions.

Articles shall be checked properly. Wherever necessary, following repairs shall be carried out properly.

1) Plain cots:

- Corroded M.S. strip shall be removed new M.S. strip shall be fixed in approved manner.
- Corroded legs shall be replaced with M.S. pipe pieces of 100mm to 150mm in length and same thickness with proper welding
- Bends & dents if any shall be removed.
- All rubber bushes shall be replaced with new bushes.

2) Plain cots with railing:

- (i) All works as per item no.1 shall be carried out.
- (ii) Corroded M.S. pipes of the railing shall be replaced.
- (iii) Any other welding work if necessary shall be carried out as the part of the work.

3) Paediatric cots:

All works shall be carried out as per item no.1 above.

4) Paediatric cots(with railing) :

All works of Paediatric cots with railing shall be carried out as per item no.2 above.

5) Labour cots (Minor Repairs) :

- (i) Replacement of corroded legs with 100mm to 150 mm long M.S. pipes of same thickness.
- (ii) All rubber bushes shall be replaced with new bushes.
- (iii) Welding work if any shall be carried out with proper grinding.

6) Labour cots (Major Repairs) :

- a) Replacement of 18 SWG G.I. Top sheet with proper welding & grinding.
- b) All other works shall be carried out as per item no.5 i.e. Labour cots.

7) Fowler Cots:

- (i) Overhauling and greasing to gear box shall be carried out so that gears shall be smoothly operated.
- (ii) Any other damaged parts of gear box shall be replaced & all other work shall be carried out as per item no.1 above.

8) Paediatric Fowler cots with railing:

- (i) works shall be carried out as per item no.7.
- (ii) All other works of Paediatric Fowler cots with railing shall be carried out as

TECHNICAL SPECIFICATIONS M&E

per item no.1 to 4.

- 9) Steel Cupboards (Big) Repairs Minor / Major:**
- (i) Corroded legs shall be repaired for minor or replaced with box type legs.
 - (ii) Repairs or replacement of bottom or any patch work shall be carried out with 18 SWG M.S. Sheet/CRCA sheet.
 - (iii) Locking arrangement of the cupboard shall be repaired/replaced if necessary.
 - (iv) Any beds or dents of the shelves shall be removed & refixed properly.
 - (v) Damaged/broken supports of shelves shall be replaced.
 - (vi) Broken /Damaged handles shall be replaced.
 - (vii) Proper alignment of doors shall be made.
- 10) Steel Cupboards (small) Major & Minor Repairs:**
Work shall be carried out as per the work of steel cupboard (Big size).
- 11) Steel Locker cupboards (6/8/9/10/12/18/24 Lockers) :**
- (i) Corroded legs shall be repaired for minor or replaced with box type legs as per item no.9
 - (ii) As per direction of site Engineer.
 - (iii) Corroded bottoms if any, shall be replaced.
 - (iv) Locking arrangement shall be repaired/ replaced.
 - (v) Any patch work shall be carried out with 18 SWG M.S. Sheet/CCA sheet.
 - (vi) Missing broken hinges shall be replaced.
- 12) Position cupboard:**
- (i) All broken glasses of 4mm, thick shall be replaced.
 - (ii) Required minor welding works shall be carried out.
 - (iii) Locking arrangement shall be repaired/ replaced.
 - (iv) Broken handle shall be replaced.
- 13) Bed side Lockers (Minor Repairs) :**
- (i) Corroded legs shall be replaced with 100 mm to 150 mm long M.S. pipes & same thickness with proper welding.
 - (ii) All rubber bushes shall be replaced.
 - (iii) Broken handle shall be replaced.
 - (iv) Locking arrangement shall be repaired.
 - (v) Damaged hinges of door shall be replaced.
 - (vi) Alignment of doors shall be carried out.
 - (vii) Corroded M.S. Sheet shall be repaired with 18 SWG M.S. sheet by patch work.
- 14) Bed side Locker major repairs :**
- (i) Top of the Bed side locker shall be replaced by 22 S.W.G.S.S.304 sheet.

TECHNICAL SPECIFICATIONS M&E

- (ii) All other works shall be carried out as per item no. 13.
- 15) **I.V.Stand :**
- (i) Damaged/broken/odd sized caster wheels shall be replaced with Bombay Star / Rexallo or any other approved make only.
 - (ii) Locking arrangement shall be checked & repaired, if required
- 16) **Medicine stands :**
- (i) Proper alignment to the frame shall be made.
 - (ii) Corroded shelves shall be replaced with 18 SWG G.I. sheet.
 - (iii) Corroded legs shall be replaced.
 - (iv) Rubber bushes shall be provided.
 - (v) Any welding work to medicine stand shall be carried out.
- 17) **Examination Tables :**
- (i) Corroded legs shall be replaced.
 - (ii) Rubber bushes shall be provided.
 - (iii) Corroded sheet shall be replaced, if necessary as per direction of the site Engineer.
 - (iv) Minor welding to frame shall be carried out.
- 18) **Steel tables (Small / big) minor repairs:**
- (i) Corroded Damaged/broken frame foot rest shall be replaced.
 - (ii) Alignment of guide rails, drawers and interlocking of drawers shall be checked & repaired.
 - (iii) Locking arrangement shall be checked repaired or replaced wherever required.
 - (iv) Broken handles shall be replaced.
 - (v) Rubber bushes shall be provided.
- 19) **Steel tables (Small/big) major repairs :**
- (i) Tables top shall be replaced with same shape and size of 18 mm commercial plywood sheet of approved quality and covered with decorative laminate of 1.5mm thick (Fornica, Greenply, or Decolam make only).
 - (ii) All other works related to minor repairs of table as per item no.18 shall be carried out.
- 20) **Oxygen Cylinder Stand/Screen Stand/drum stand:**
Broken /Damaged caster wheels shall be replaced corroded legs shall be replaced and all rubber bushes shall be provided. The caster wheels shall be Bombay Star or Rexallo or any other approved make.
- 21) **Food Trolley / Sretcher Trolley /Patient Trolley / Suction Machine Trolley / Dressing Trolley/Instrument Trolley / Cauty machine stand:**
- (i) Broken /Damaged caster wheels shall be replaced corroded legs shall be replaced and all rubber bushes shall be provided. The caster wheels shall be Bombay Star or Rexallo or any other approved make only.
 - (ii) Corroded sheet shall be replaced with 18 SWG

TECHNICAL SPECIFICATIONS M&E

G.I.sheet/CRCA sheet.

- (iii) Any welding work to frame shall be carried out.
 - (iv) All work related to T.T. Splint shall be carried out.
- 22) **M.S. Rack 3 shelves to 8 shelves :**
- (i) Bend of M.S. frame & shelves shall be removed.
 - (ii) Corroded portion of frame/ legs shall be replaced with by same shape, size and thickness.
 - (iii) Corroded shelves portion of equal shape shall be replaced with CRCA sheet of same thickness.
- 23) **Steel filling cabinets:**
- (i) Over Corroded/broken/damaged portion of cabinet shall be replaced by equal shape, size & thickness.
 - (ii) Alignment of drawers shall be checked& repaired, complete with guide channels for smooth movement of drawer.
 - (iii) Interlocking arrangement of drawers shall be checked and repaired if necessary.
 - (iv) Broken/ Damaged handles shall be replaced
 - (v) Locking arrangement shall be repaired/replaced if required.
- 24) **Portable Shadowless Lamp :**
- (i) All broken/missing caster wheels shall be replaced.
- 25) **Wheel Chairs:**
- (i) Remove bend of the frame.
 - (ii) Broken axles steel balls, rubber tyres shall be replaced while overhauling.
 - (iii) Corroded back/seat/foot step shall be replaced with 18 SWG G.I. sheet.
 - (iv) Caster wheels shall be repaired/replaced as directed of approved make.
 - (v) Any other work related to wheel chairs shall be carried out.
- 26) **Steel canned chairs:**
- (i) Broken/damaged seat/back shall be replaced.
 - (ii) Remove bend of the frame
 - (iii) Broken/damaged arm rest shall be replaced.
 - (iv) Damaged/ Broken seat/back shall be replaced.
 - (v) Rubber bushes shall be provided.
- 27) **Mayors Trolley:**
- (i) Locking arrangement shall be repaired.
 - (ii) Broken caster wheels shall be replaced.
 - (iii) Any other welding work to the trolley shall be carried out.

TECHNICAL SPECIFICATIONS M&E

28) Revolving stool:

- a) Revolving top arrangement shall be repaired.
- b) Any other welding work to stool shall be carried out.

29) Steel Stools:

Corroded/damaged top shall be replaced, if necessary.

- (i) Minor welding to frame shall be carried out.
- (ii) Any other work related to above items shall be carried out as directed.
- (iii) Cylindrical bend shall be perfectly removed from proper fitment of the cover.
- (iv) Buffing and polishing to drums shall be carried out.

PAINTING:

After carrying out the repair works, of furniture items, surface preparation by scrapping, of old paint shall be carried out. All surfaces shall be cleaned, and smooth, surfaced by using th cellulose putty of Asian paints or of Esdee make. After making smooth surfaces, one coat of red oxide and two coats of synthetic enamel paint of Asian paints make of Apcolite brand shall be applied. The recommended shades shall be white/olive green/smoke Grey and any other approved shade as directed by the Engineer.

WELDING:

All welded joints shall be smooth and without excessive weld. The flux shall be removed and the joints shall be finished by removing burr. The welding rods of Adwani Oerlicon make shall be used.

Floor Coating:-

Technical Specification

- Impermeable to water, oil & chemicals.
- High resistance to wear & abrasion.
- Environment friendly.
- Excellent mechanical properties.
- Electrical Insulation : Tested for insulation for 11 KV @ 1.5 mm thick coating and tested for insulation by ERDA for 47.9 KV @2.5 mm thickness.
- Include Anti-microbial system.
- Joint less.
- Reduces the maintenance and cleaning cost.
- Uplifts in aesthetics.
- Easy and quick to repair.

TECHNICAL SPECIFICATIONS M&E

- Compressive strength : 650 - 900 kg/square cm
- Flexural strength : 260 - 350 kg/square cm
- Abrasion Resistance : 0.3 to 0.5 mg/cycle
- Density : 1800 - 2100 kg/square meter
- Pot Life : @30°C → 30 minutes
- Coverage : @2mm thick 3 kgs. Per 10 square feet
@3mm thick 4.5 kgs. Per 10 square feet

METHODOLOGY;-

Depending upon the condition and nature of sub-floor, necessary methods of surface preparation shall be adopted.

Concrete floor treatment

- Sand/Grit blasting: Steel grits are used for scouring of metals.
Flame sparging: For removal of contaminated oil, fats, organics etc.
Chemical cleaning: Acid cleaning of surface followed by water wash.
After surface preparation : cleaning the surface from dust and loose particles.
- Applying primer coat on treated surface
- Applying the requisite system
- Curing for 48 hours

SP-ME-TS-37: EARTHING & LIGHTENING PROTECTION:

Earthing:

Earthing shall be conforming to IS 3043.

Providing earthing station at service, DB's and panels, pumps etc. with earthing plate / pipe in earth pit, connected to earth wire by means of nut bolts and washers, earth wire shall be brought to the surface & terminated at earth station by means of crimping type lugs. The size of earth conductor shall be not less than GI strip of 25 mm X 3 mm. Complete with providing and connecting to pipe / plate electrode and earth terminals, socket, lug and crimping hardware by using of H.G., G.I. Wire from earthing plate to test terminal upto 6 mtrs. and test terminal to service position upto 6 mtrs. complete with excavation. The cost of earth wire above 6 mtrs shall be paid separately. The pit shall be backfilled with, salt, charcoal alternate layers and finally with soft soil. Earthing shall be strictly carried out as per Indian Standard Specifications by using 20 mm dia. 'B' Class G.I. Pipe for pouring water, funnel and masonry chamber with hinged type fully open-able C.I. Cover with C.I. Frame for testing and watering purpose. The test link shall be provided as per I.S.

The charges for the above work are included in the cost of the earthing.

Lightening Protection:

- (i) Providing one set of 5 pronged air terminals, projecting at least App.300 mm. in length comprising App. 100 mm.dia. Copper hollow sphere. It shall be fitted on App. 25 mm.dia. copper tube with not less than 2 mm. wall thickness and 1.2 meter in length to be welded to suitable size M.S./G.I. base plate which shall be grouted to the parapet wall/slab at the highest level of the bldg. as per site condition with 4 Nos. Of **G.I. nuts, bolts and washers.**
- (ii) Supply and fixing common bus G.I./Copper flat complete with nuts & bolts washer for termination of earth wires coming from different points fixing clamps hardware etc. The earth bus shall be fixed on wall with proper mounting arrangement in approved manner. The bus shall be either connected with welded to the other earth bus.
- (iii) Separate two earthing stations shall be provided at two different places (5 Mtrs. apart) and shall be connected to earth bus, grid and lightening protection.

Supply and fixing earthing bare wire G.I./copper as instructed to be laid along with cables or from panel to switchgear 'DB's / equipments etc.

Continuous earth conductor shall be provided for surface cable.

TECHNICAL SPECIFICATIONS M&E

S.I.T.C of low impedance grounding (Digital Earthing)-240 KVA capacities:-

The low impedance grounding device of 240 KVA, rated voltage-380-415V, 3 phase, 50-60Hz shall CE approved as per IEC 61643, IEC 61000-4-5, IEC 61000-6-1 and IEC 61000-6-3 comply with EMC directive 89/336/EEC amended by 92/31/EEC. xi) The LIG shall be CE approved as per IEC 61643, IEC 61000-4-5, IEC 61000-6-1, and IEC 61000-6-3 Standards. The low impedance grounding device shall comply with EMC directive 89/336/EEC amended by 92/31/EEC. The system shall be enclosed in prewired enclosure. The surge handling capacity shall be maximum 240kA. The nominal discharge current shall be 10kA in each mode and maximum discharge current shall be 40kA in each mode. The standby power consumption shall be maximum 1.32vA and residual current shall be 0.001A. The assured bonding potential shall be ≤ 1.0 V between earth and neutral. The unit shall have inbuilt Rj45 jack for diagnostics.

S.I.T.C of low impedance grounding (Digital Earthing)-120 KVA capacities:-

The low impedance grounding device of 120 KVA, . The rated voltage of low impedance grounding device shall be 190-230V, 1 phase, 50-60Hz. xi) The low impedance grounding device shall be CE approved as per IEC 61643, IEC 61000-4-5, IEC 61000-6-1, and IEC 61000-6-3 Standards. LIG shall comply with EMC directive 89/336/EEC amended by 92/31/EEC. LIG shall be type tested in an International/National reputed laboratory as per IEC-61643-1-2006, IEC6100-4-5(2005.11), IEC61000-6-1, and IEC61000-6. LIG system shall be enclosed in prewired enclosure. The surge handling capacity shall be maximum 120 kA. The nominal discharge current shall be 10kA in single mode and maximum discharge current shall be 120 kA in single mode. The standby power consumption shall be maximum 1.32vA and residual current shall be 0.001A. The assured bonding potential shall be ≤ 1.0 V between earth and neutral. The unit shall have inbuilt Rj45 jack for diagnostics

TECHNICAL SPECIFICATIONS M&E

SP-ME-TS-38: TESTING AND INSPECTION EARTHING & LIGHTENING PROTECTION

This specification covers design, engineering, manufacture, testing & inspection in accordance with agreed QAP at manufacturer's/ vendors' works, packing, forwarding and delivery/ supply from manufacturer's works to erection site including transit insurance, octroi/ state taxes etc. unloading, storage at site, assembly, erection, testing, installation,

commissioning and performance demonstration of Earthing and Lightning protection system as specified in this specification.

The safety earthing and lightning protection system will be generally on the basis of following codes and standards.

- (i) IS 3043-1987 Code of practice for Safety Earthing
- (ii) IEEE 80 – 2000, IEEE 42
- (iii) IS 2309-1989-Code of Practice for the protection of buildings and allied structures against lightning.
- (iv) Indian Electricity Rules – 1956.

Following factors will be considered for sizing the earthing conductor

- (i) Design Ambient Temperature 45 Deg C
- (ii) Allowable temperature rise 500 Deg C for steel welded joints
- (iii) Fault clearing time 1.0 Seconds
- (iv) Overall earthing resistance less than 3.0 ohm

In general, minimum two (2) earth leads shall be used for earthing each equipment/structure enclosing the power conductor operating at more than 250 Volts and one (1) earth lead if voltage level is 250V or less.

Structure, Substation, office building etc. will have an earth grid laid in cable tray, trench/buried in the ground. The main earthing grid shall be embedded below ground level at a minimum depth of 600 mm which shall be connected to earth electrodes. All interconnections of the earthing grid conductors will have welded type joints except at electrodes with disconnecting facility and at equipment with bolted connections. All indoor earthing grids will be suitably interconnected to the outdoor earthing grid.

All the non-current carrying metal parts of electrical installation such as metal conduits, switchgear, distribution switch boards and all other parts of the metal shall be bonded together and connected by means of two separate earth continuity conductor to earth electrode.

For IT racks requirements, dedicated earthing shall be considered for Server racks and UPS system.

TECHNICAL SPECIFICATIONS M&E

Frames of all 230V/415V electric motor shall be connected to the earthing system by two distinct paths.

Internal earth Bus of each PDB / DB shall be connected to both ends to the earthing system by means of earthing conductor

Earthing Pit - Pit shall be provided as per IS3043.

- (i) GI Pipe Earthing :- Earthing station with 100mm Dia., 13mm thick, 3000 mm long GI pipe (Class B or better) earth pit as per IS 3043. The earth pit shall be provided with watering pipe (Class B) with wire meshed funnel, 25x3mm GI strip /2X8SWG G.I. wire up to chamber (wire or strip size as per fault level), disconnecting links with 600 x 600 mm (clear) RCC chamber & heavy duty 3mm thick CI chequered plate cover with hinge & stainless steel bolts. Bentonite/ Charcol (40kg) & Salt (40Kg) shall be provided for earth pits. Excavation, backfilling, removal of excess soil is included in the scope (Refer IS 3043 page 24/25 std. Dwg.)
- (ii) GI Plate Earthing :- Earthing station with 600 mm x 600 mm x 6 mm galvanised iron plate & 50 mm dia. G.I. pipe, 3000mm long GI pipe (Class B or better) earth pit as per IS 3043. The earth pit shall be provided with watering pipe (Class B) with wire meshed funnel, 25x3 GI strip/ 2X8SWG G.I. wire up to chamber (wire or strip size as per fault level), disconnecting links with 600 x 600 mm (clear) RCC chamber & heavy duty 3mm thick CI chequered plate cover with hinge & stainless steel bolts. Bentonite/ Charcol (40Kg) & Salt (40Kg) shall be provided for earth pits. Excavation, backfilling, removal of excess soil is included in the scope (Refer IS 3043 page 24/25 std. Dwg.)
- (iii) Cu Plate Earthing 600 X 600 X 3.15 mm Copper Plate, 3000mm dip with suitable size cu strip earth pit as per IS 3043. The earth pit shall be provided with watering pipe (Class B) with wire meshed funnel, 25X3 mm Cu strip/ 2X8SWG Cu. wire up to chamber, disconnecting links with 600 x 600 mm (clear) RCC chamber & 3mm thick heavy duty CI chequered plate cover with hinge. Bentonite shall be provided for earth pits. Excavation, backfilling, removal of excess soil is included in the scope

General requirement:-

- (i) Providing earthing station at service, DB's and panels, pumps etc. with earthing plate/ pipe in earth pit, connected to earth wire by means of nut bolts and washers, earth wire shall be brought to the surface & terminated at earth station by means of crimping type lugs. The size of earth conductor shall be not less than GI strip of 25 mm X 3 mm. Complete with providing and connecting to pipe / plate electrode and earth terminals, socket, lug and crimping hardware by using of H.G., G.I. Wire from earthing plate to test terminal upto 6 mtrs. and test terminal to service position upto 6 mtrs. Complete with excavation. The cost of earth wire above 6 mtrs shall be paid separately.
- (ii) Earthing shall be strictly carried out as per Indian Standard Specifications by using 20 mm.dia. 'B' Class G.I. Pipe for pouring water.

TECHNICAL SPECIFICATIONS M&E

- (iii) The test link shall be provided as per I.S.

Lightning Protection

- The lightning protection system need will be established by calculating the risk factor value of each building, structure etc. as per procedure given in IS 2309-1989. This will be provided for building(s) whose risk factor is more than 1×10^{-5}
- Lightning Protection system shall meet the requirement of IEC 1024-1, IEC 62-305-4.
- Providing one set of 5 pronged air terminal, projecting at least App.300 mm. in length comprising App. 100 mm.dia. Copper hollow sphere. It shall be fitted on App. 25 mm.dia. copper tube with not less than 2 mm. wall thickness and 1.2 meter in length to be welded to suitable size M.S./G.I. base plate which shall be grouted to the parapet wall/slab at the highest level of the bldg. as per site condition with 4 Nos. Of

G.I. nuts, bolts and washers.

- (i) Supply and fixing common bus G.I./Copper flat complete with nuts & bolts washer for termination of earth wires coming from different points fixing clamps hardware etc. The earth bus shall be fixed on wall with proper mounting arrangement in approved manner. The bus shall be either connected with welded to the other earth bus.
- (ii) Separate two earthing stations shall be provided at two different places (6 Mtrs. apart) and shall be connected to earth bus, grid and lightning protection.

Distance between 2 earth electrodes shall be minimum 6000mm.

- (i) Supply and fixing earthing bare wire G.I./copper as instructed to be laid along with cables or from panel to switchgear 'DB's / equipments etc.
- (ii) Continuous earth conductor shall be provided for surface cable.

TECHNICAL SPECIFICATIONS M&E

SP-ME-TS-39 SOLAR STREET LIGHTING SYSTEM (CFL): A stand alone solar photovoltaic street lighting system should have compact fluorescent lamp Lithium Ion battery, PV module, control electronics, interconnecting wires/cables, Module mounting hardware, Battery Box, operation instructions & maint. Manual. The system should be designed to automatically switch ON at dusk, operate throughout the night & automatically switch of at the down under average daily isolation of 5kwh/sq.m. on a horizontal surface.

1) Lamp

The lamp will be of CFL type , either 4-pin or 2-pin type with a rating of 11 w. For the 4 –pin CFL, adequate pre- heating ckt. must be provided. The light output from the lamp should be 900+/-5% lumens. The lamp should be housed in a weatherproof assembly suitable for outdoor use with reflector on its back. While fixing the assembly, the lamp should be held in a base up configuration.

Battery -Lithium Ion Battery

Cycle Life :- Rechargeable lithium-ion batteries have a lifespan of 2000 to 5000 charge cycles.

Performance:- Lithium-ion batteries maintain the same amp hour rate while charging and discharging.



TECHNICAL SPECIFICATIONS M&E

SP-ME-TS-40 SOLAR STREET LIGHTING SYSTEM (LED FIXTURES):

The light source will be of white multiple LEDs of reputed make of not less than 1 Watt of each 120 degrees wide view angles. The luminous performance of Led should not be less than 80 lumen/watt LED. The LED shall be placed in individual heat sink and reflector cone. The input power should not exceed 5 watt for 5 watt fixture/10 watt for 10 watt fixture/12Watts for 12 watt fixture/18watt for 18 watt fixture/24watt for 24 watt fixture. The light output should remain constant with variation with battery voltage. The LED lamps should be housed in an assembly suitable for outdoor use with IP 55 protection. The make, model no. country of origin and technical characteristics of LEDs should be furnished to MCGM. It should have minimum central illumination at the height of 4 mtr. for 5 watt fixture 8-10 LUX/for 10 watt 20 -25 LUX/ for12 watt 25 -30 lux/for 18 watt 35-40 Lux and for 24 watt 50-55 lux. The Dusk-to-Dawn controller and battery charger shall be built into the fitting. LED fitting should be provided with acrylic cover.

PV module: should sense the ambient light level for switching ON & OFF the lamp. It should contain crystalline/polycrystalline silicon solar cells for 5 watt 20 WP/10 watt 35-37 WP/12 watt 50 WP/18 watt 74 WP and for24watt 80-100 WP under STC measured power output. The terminal box on the module should have provision for opening for replacing the cable if required. A strip containing the following details should be laminated inside the module so as to be clearly visible from the front side.

- (i) Name of manufacturer with logo.
- (ii) Module or type no.
- (iii) Sr.No. and Year of make etc.

1. Battery:

Battery -Lithium Ion Battery

Cycle Life :- Rechargeable lithium-ion batteries have a lifespan of 2000 to 5000 charge cycles.

Performance:- Lithium-ion batteries maintain the same amp hour rate while charging and discharging.

Electronics:

- (i) The LED Lamp's electronics efficiency excluding blocking diode should be at least 80%.
- (ii) Electronic should operate on 12V and should have temp. compensation for proper charging of the battery throughout the year.
- (iii) The light output should remain constant with variation in the battery voltages.
- (iv) Necessary lengths of wires/cables, switches suitable for DC use and fuses shall be provided.

TECHNICAL SPECIFICATIONS M&E

2. Pole:

should be 5.5 mtr. Height & 65mm dia. GI pipe 1 mtr. Grouted in the 0.5 x 0.5 x 1 mtr. Pit in cement 1:2:4 ratio. After grouting, height of pole should be 4 mtr. Above ground level. Arm bracket of 4 feet length & 25mm dia. G. I. pipe should be provided for LED fitting. The pole has the provision to hold the weatherproof lamp housing. The metallic frame structure should have fixed suitable angle of inclination to the horizontal as per requirement of site and Mumbai geographical requirement. It should be painted with corrosion resistant paint. Each equipment should be suitably protected.

3. Electronic Protection:

Adequate protections are to be incorporated under no load conditions when the lamps are removed and system is switched ON.

The system should have protection against battery overcharge and deep discharge conditions. The numerical value of the cut off limit must be specified.

Fuses should be provided to protect against short circuit conditions.

A blocking diode should be provided as part of the electronics, to prevent the reverse flow of current through the PV module(s) in case such diode not provided with PV modules.

Full protection against open circuit, accidental short circuit and reverses polarity should be provided.

4. Mechanical Component:

Metallic frame with corrosion resistant paint to be fixed on the top of the pole to hold the PV module.

It should be possible to mount the light source on a metallic arm attached to the pole. The metallic arm for holding the light assembly will be extended for 4 feet from the pole or as directed by site engineer and set at suitable tilt angle to provide uniform illumination over the specified area.

A vented metallic/plastic/wooden box with acid proof corrosion resistance paint for housing the storage battery indoor should be provided.

5. Other features:

The system should be provided two LED indicators, green to indicate charging in progress and red LED to indicate deep discharge of battery.

The name plate shall be fixed on system with details of Manufacturer with logo & sr.no.

Quality & Warranty: The street light system should be maintained and warranted for three years. It should be secured by way of insurance & any theft cases it is responsibility of the contractor.

Documentations: Operation & maintenance and instruction manual should be provided with the following details.

TECHNICAL SPECIFICATIONS M&E

- (i) About photovoltaic: LED solar system, its component and expected performance.
- (ii) About LED lamps: the make, model no and technical characteristics of LED should stated in the product data sheet and furnished to the MCGM.
- (iii) About battery : clear instruction about installation of PV module, charging and signification of indicators, Doe's and Don't s, clear instructions on regular maintenance and trouble shooting of solar light systems. Name and address of the person of service center to be contacted in case failure or complaint.

TECHNICAL SPECIFICATIONS FOR ITEM SITC of 20W LED Solar Street Lighting System with 5 years Warranty

- 1) The light source will be of white multiple LEDs on Aluminium PCB of reputed make and having 120 degrees wide view angles. The colour rendering index shall be more than equal to 80. The colour temperature should be in the range 5500-6500 kelvin. The total luminous output shall be more than 3000 lumens at Full bright.
- 2) The input power should not exceed 20 Watt for 20 Watt fixture.
- 3) The light output should remain constant with variation with battery voltage. The Solar Street lights shall be of Integrated type and ,Solar panel, Battery, electronic circuit should be housed in one single Aluminium casing/FRP assembly suitable for outdoor use with IP 65 protection. The 20W LED Aluminium Die Cast Luminary shall be fitted to adjustable arm.
- 4) It should have minimum central illumination of 50-55 LUX at the height of 5.0m.
- 5) The Dusk-to-Dawn controller and battery charger shall be built into the fitting.
- 6) PV module should sense the ambient light level for switching ON & OFF the lamp. It should contain crystalline/ polycrystalline silicon solar cells for 75 Wpk, 18 V under STC. A strip containing the following details should be laminated inside the module so as to be clearly visible from the front side.
 - i) Name of manufacturer with logo.
 - ii) Module or type no.
 - iii) Sr. No. and Year of make.
- 7) Battery should be Lithium-ion maintenance free battery. Battery should conform to latest BIS standard or international standards. Battery should be having minimum rating of 11.2V for 293WH(26.4 AH). The charging time should be 6-8 hrs.
- 8) Electronics:
 - i. The LED Lamp's electronics efficiency excluding blocking diode should be at Least 80%.
 - ii. Electronic should operate on 12V and should have temperature compensation for proper charging of the battery throughout the year.
 - iii. The light output should remain constant with variation in the battery voltages.
 - iv. Necessary lengths of wires/cables, switches suitable for DC use and fuses shall be provided.
- 9) Pole should be 6.0 mtr. height & 73mm dia.(O.D.) GI pipe of 2.5mm thickness and 1 mtr. grouted in the 0.5 x 0.5 x 1 mtr. Pit in cement 1:2:4 ratio. After grouting, height of

TECHNICAL SPECIFICATIONS M&E

pole should be 5.0 mtr. above ground level. Adjustable Arm bracket of suitable size of G. I. pipe shall be provided for LED fitting. The pole should have the provision to hold the weatherproof lamp housing. The metallic frame structure should have fixed suitable angle of inclination to the horizontal as per requirement of site and Mumbai geographical requirement. It should be painted with corrosion resistant paint. Each equipment should be suitably protected.

- 10) It should have integrated PIR sensors for motion detection.
- 11) The operating temperature should be -25 to +65 degree celsius.
- 12) The autonomy shall be minimum two nights or 24 hrs.
- 13) Electronic Protection:
 - (i) Adequate protections are to be incorporated under no load conditions when the lamps are removed and system is switched ON.
 - (ii) The system should have protection against battery overcharge and deep discharge conditions. The numerical value of the cut off limit must be specified.
 - (iii) Fuses should be provided to protect against short circuit conditions.
 - (iv) A blocking diode should be provided as part of the electronics, to prevent the reverse flow of current through the PV module(s) in case such diode not provided with PV.
 - (v) Full protection against open circuit, accidental short circuit and reverses polarity should be provided.
- 14) Mechanical component:
 - (i) The name plate shall be fixed on system with details of Manufacturer with logo & Sr. no. and Contact no. of Contractor/technical person of company.
 - (ii) **The Integrated solar street light system should be maintained and warranted for Five Years.** It should be secured by way of insurance & any theft cases it is responsibility of the contractor.
- 15) Operation & maintenance and instruction manual should be provided with the following details.
 - (i) About photovoltaic: LED solar system, its component and expected performance.
 - (ii) About LED lamps: the make, model no. and technical characteristics of LED should state in the product data sheet and furnished to the MCGM.
 - (iii) About battery: clear instruction about installation of PV module, charging and signification of indicators, Do's and Don'ts, clear instructions on regular maintenance and trouble shooting of solar light systems. Name and address of the person of service centre to be contacted in case failure or complaint.

Special Instructions

1. All the solar lights shall be visually inspected every week for their proper functioning.
2. The solar panels shall be cleaned with water once in a month in presence of the Engineer of (M&E) section & report shall be submitted to concern Engineer.
3. All the connections i.e. PV module, Fixture, battery terminals etc. shall be checked and tightened properly during maintenance, every month.
4. Charging of battery shall be checked and jelly shall be applied to the terminals of the battery, every month.
5. If the solar street light is not working properly, the same shall be inspected and minor repairs such as replacement of wire, connector etc. shall be replaced immediately.
6. The pole shall be painted once in year by anti corrosive paint. Old paint shall be removed completely and one coat of red oxide shall be applied.



TECHNICAL SPECIFICATIONS M&E

SP-ME-TS-41 DOUBLE WALL CORRUGATED PIPES:

For underground cable protection, supply and laying of Double Wall Corrugated (DWC) pipes of HDPE with IS-14930 part II mark on it. With necessary connecting sockets/couplings, tees of some material at required depth upto 90 c.m. below road ground surface, back filling with light ramming to make road/ground surface as it was (except bitumen carpets).



SP-ME-TS-42 HIGHMAST:

1) HIGH MAST LIGHTING.

SCOPE:

- (i) The scope of this specification covers the design, manufacture, transport, installation, testing and commissioning of the complete lighting system, using Raising and Lowering type of High mast Towers, including the Civil Foundation Works. All items required for the safe and efficient operation and maintenance of the lighting system, including the high mast.
- (ii) The scope of this specification covers the Design, engineering, manufacture, testing at factory, packing & forwarding, delivery to site, unloading and handling at site, assembly, installation, testing and commissioning of Hot Dipped galvanised octagonal high mast lighting system, including raising lowering mechanism,

Foundation for the mast and all the civil works. All items required for the safe and efficient operation and maintenance of the lighting system, including the high mast.

APPLICABLE STANDARDS:

The following shall be the Reference Standards for the loading of the High mast:

Code No.	Title
(i) I.S.875 (Part III) 1987.	Code and practice for design loads for Structures.
(ii) BSEN 10025/DIN 17100.	Grades of MS. Plates.
(iii) BS. 5135/AWS.	Welding.

TECHNICAL SPECIFICATIONS M&E

(iv)	BS.ISO 1461.	Galvanising.
(v)	TR. No.7 1996 of ILE, UK.	Specification for Mast and foundation.
(vi)	IS 2062	Mild Steel
(vii)	IS 3459 / 2266	Stainless steel Wire rope
(viii)	IS 9968 Part – 1	EPR/PCP Trailing cable
(ix)	IS325	Motor

HIGHMAST

Structure:

- (i) The Highmast shall be of continuously tapered, polygonal cross section, at least 20 sided, presenting a good and pleasing appearance and shall be based on proven In- Tension design conforming to the standards referred to above, to give an assured performance, and reliable service. The structure shall be suitable for wind loading as per IS 875 part3 1987. The manufacturer should have carried out the wind tunnel test on sample model of high mast and relevant test certificates to be submitted.
- (ii) The high mast shall be of continuously tapered, polygonal cross section construction. The mast shall be fabricated from steel plates in suitable number of sections, telescopically jointed giving a continuous tapered profile and presenting good visual appearance and shall be based on proven In-Tension design conforming to the standards referred to above, to give an assured performance, and reliable service. The base flange shall be provided with gaskets and high tensile anchor bolts. The bottom section shall have adequate sized opening with a hinged door to accommodate electric drive for winch, cable, plug socket, etc. The opening shall be such as to permit clear access to the above components inside the mast. The opening shall be complete with a close fitting, vandal proof, dust and vermin proof door, weather protected IP55 or better with gaskets of durable material and provided with a heavy-duty double locking arrangement.
- (iii) The manufacturer should have carried out the wind tunnel test on sample model of high mast and relevant test certificates to be submitted.
- (iv) The structure shall be suitable for wind loading as per IS 875 part3 1987.
- (v) The means for natural ventilation of the mast shall be provided.
- (vi) The mast shall have integral power tool for winch drive.
- (vii) The mast shall have stainless earthing terminal at convenient location in the base compartment for lightning & electrical earthing.
- (viii) Lightning rod at the top of the mast for the lightning protection of the lighting mast system as per standard: IS-2309 shall be provided.
- (ix) The embedded junction box of the mast shall have padlocking arrangement in the centre and 2 Nos. Allen bolts at top and bottom.

TECHNICAL SPECIFICATIONS M&E

- (x) The complete design of the mast and associated foundation shall be such that mast is structurally and mechanically safe. Structural Design calculation for mast shall be submitted along with the proposal.

Construction:

The mast shall be fabricated from special steel plates, conforming to BS-EN10025 or equivalent, cut and folded to form a polygonal section as stated at 3.01 above and shall be telescopically jointed and welded. The welding shall be in accordance with BS.5135/AWS. The procedural weld geometry and the workmanship shall be exhaustively tested on the completed welds.

The mast shall be in two sections upto 20 mtrs., in 2 sections for 20 to 30 mtrs. in 3 sections of suitable length as per manufacturers standard and approved by site engineer. Each section shall be fabricated out of individual plates duly folded and welded. There shall be only one longitudinal seam weld per section. Sections fabricated out of multiple plates or with more than one weld shall not be accepted. At site the sections shall be joined together by slip-stressed-fit method. No site welding or bolted joint shall be done on the mast. The minimum over lap distance shall be 1.5 times the diameter at penetration. The dimensions of the mast shall be decided based on proper design and design calculations shall be submitted for verification. The mast shall be provided with fully penetrated flange, which shall be free from any lamination or incursion. The welded connection of the base flange shall be fully developed to the strength of the entire section. The base flange shall be provided with supplementary gussets between the bolt-holes to ensure elimination of helical stress concentration. For the environmental protection of the mast, the entire fabricated mast shall be hot dip galvanised, internally and externally, having a uniform thickness As per BSEN ISO-1461. The galvanizing has to be done by single dipping method only for better adhesion and life.

Door Opening:

An adequate door opening shall be provided at the base of the mast and the opening shall be such that it permits clear access to equipment like winches, cables, plug and socket, etc. and also facilitate easy removal of the winch. The door opening shall be complete with a close fitting, vandal resistant, weatherproof door, provided with a heavy-duty double internal lock with special paddle key. The door opening shall be carefully designed and reinforced with welded steel section, so that the mast section at the base shall be unaffected and undue buckling of the cut portion is prevented. Size of door opening shall not be more than 1200 x 250 mm to avoid buckling of the mast section under heavy wind conditions.

Dynamic Loading for the Mast:

The mast structure shall be suitable to sustain an assumed maximum reaction arising from a wind speed as per IS 875 (three second gust), and shall be measured at a height of 10 metres above ground level. The design life of the mast shall be a minimum of 25 years.

TECHNICAL SPECIFICATIONS M&E

Lantern Carriage:

(i) Fabrication:

A fabricated Lantern Carriage shall be provided for fixing and holding the flood light fittings and control gear boxes. The Lantern Carriage shall be of special design and shall be of steel tube construction, the tubes acting as conduits for wires, with holes fully protected by grommets. The Lantern Carriage shall be so designed and fabricated to hold the required number of flood light fittings and the control gear boxes, and also have a perfect self balance. The Lantern Carriage shall be fabricated in two halves and joined by bolted flanges with stainless steel bolts and nyloc type stainless steel nuts to enable easy installation or removal from the erected mast. The inner lining of the carriage shall be provided with protective PVC arrangement, so that no damage is caused to the surface of the mast during the raising and lowering operation of the carriage. The entire Lantern Carriage shall be hot dip galvanised after fabrication.

(ii) Junction Box:

Weather proof junction box, made of Cast Aluminium shall be provided on the Carriage Assembly as required, from which the inter-connections to the designed number of the flood light luminaries and associated control gears fixed on the carriage shall be made.

Raising and lowering mechanism:

For the installation and maintenance of the luminaries and lamps, it shall be necessary to lower and raise the Lantern Carriage Assembly. To enable this, a suitable Winch Arrangement shall be provided, with the winch fixed at the base of the mast and the specially designed head frame assembly at the top.

Winch:

The winch shall be of completely self sustaining type, without the need for brake shoe, springs or clutches. Each driving spindle of the winch shall be positively locked when not in use, by gravity activated PAWLS. Individual drum also should be operated for fine adjustment of lantern carriage. The capacity, operating speed, safe working load, recommended lubrication and serial number of the winch shall be clearly marked on each winch.

The gear ratio of the winch shall be 53: 1. The winch shall be self-lubricating type by means of an oil bath. The oil shall be readily available grades of reputed producers.

The winch drums shall be grooved to ensure perfect seat for stable and tidy rope lay, with no chances of rope slippage. The rope termination in the winch shall be such that distortion or twisting is eliminated and at least 5 to 6 turns of rope remains on the drum even when the lantern carriage is fully lowered and rested on the rest pads. It shall be possible to operate the winch manually by a suitable handle and by an integral power tool. Operation of the winch with manual handle shall be independent of the power tool. Winches with manual operation through the power tool shaft shall not be accepted. Individual drum operation of the winch shall be possible. A double drum winch shall have 2 drums and two worm gears independent in operation for increased safety. It shall be possible to remove the double drum after dismantling, through the

TECHNICAL SPECIFICATIONS M&E

door opening provided at the base of the mast. Also, a winch gearbox for simultaneous and reversible operation of the double drum winch shall be provided as part of the contract.

The winch shall be type tested in presence of a reputed Institution and the test certificates shall be furnished before supply of materials. A test certificate shall be furnished by the Contractor for each winch in support of the maximum load operated by the winch.

Head Frame:

The head frame which is to be designed as a capping unit of the mast shall be of welded steel construction, galvanised both internally and externally after assembly. The top pulley shall be of appropriate diameter, large enough to accommodate the stainless steel wire ropes and the multi-core electric cable. The pulley block shall be made of non-corrodable material, and shall be of die cast Aluminium Alloy (LM-6). Pulley made of synthetic materials such as Plastic or PVC is not acceptable. Self-lubricating bearings and stainless steel shaft shall be provided to facilitate smooth and maintenance free operation for a long period. The pulley assembly shall be fully protected by a canopy galvanised internally and externally.

Close fitting guides and sleeves shall be provided to ensure that the ropes and cables do not dislodge from their respective positions in the grooves. The head frame shall be provided with guides and stops with PVC buffer for docking the lantern carriage.

Stainless Steel Wire Ropes:

The suspension system shall essentially be without any intermediate joint and shall consist of only non-corrodable stainless steel of AISI 316 or better grade.

The stainless steel wire ropes shall be of 7/19 construction. The overall diameter of the rope shall not be less than 6 mm. The breaking load of each rope shall not be less than 2350kg. giving a factor of safety of over 5 for the system at full load as per the TR-7 referred to in the beginning of this specification. The end constructions of ropes to the winch drum shall be fitted with talurit.

The thimbles shall be secured on ropes by compression splices. Two continuous lengths of stainless steel wire ropes shall be used in the system and no intermediate joints are acceptable in view of the required safety. No intermediate joints/terminations, either bolted or else, shall be provided on the wire ropes between winch and lantern carriage.

Electrical System, Cable and Cable Connections:

A suitable terminal box shall be provided as part of the contract at the base compartment of the high mast for terminating the incoming cable. The electrical connections from the bottom to the top shall be made by special trailing cable. The cable shall be EPR insulated and PCP sheathed to get flexibility and endurance. The cable shall be of reputed make. At the top there shall be weather proof junction box to terminate the trailing cable. The system shall have in-built facilities for testing the luminaries while in lowered position. Also, suitable provision shall be made at the base compartment of the mast to facilitate the operation of internally mounted, electrically

TECHNICAL SPECIFICATIONS M&E

operated power tool for raising and lowering of the lantern carriage assembly. The trailing cables of the lantern carriage rings shall be terminated by means of specially designed, metal clad, multi pin plug and socket provided in the base compartment to enable easy disconnection when required.

Power Tool for the Winch:

A suitable, high-powered, electrically driven, internally mounted power tool, with manual over ride shall be supplied for the raising and lowering of the lantern carriage for maintenance purposes. The speed of the power tool shall be to suit the system. The power tool shall be single speed, provided with a motor of the required rating.

The power tool shall be supplied complete with a suitable control arrangement so that the operation of the mast can be done at a safe distance. The capacity and speed of the electric motor used in the power tool shall be suitable for the lifting of the design load installed on the lantern carriage.

The power tool mounting shall be so designed that it shall be not only self supporting but also aligns the power tool perfectly with respect to the winch spindle during the operations. Also, a handle for the manual operation of the winches in case of problems with the electrically operated tool, shall be provided. There shall be a separate torque-limiting device to protect the wire ropes from over stretching. It shall be mechanical with suitable load adjusting device. The torque limiter shall trip the load when it exceeds the adjusted limits. There shall be suitable provision for warning the operator once the load is tripped off. The torque limiter is a requirement as per the relevant standards in view of the overall safety of the system. Each mast shall have its own power tool motor.

Lightning Finial:

One number heavy duty hot dip galvanised lighting finial shall be provided for each mast. The lightning finial shall be minimum 1.2 M in length and shall be provided at the center of the head frame. It shall be bolted solidly to the head frame to get a direct conducting path to the earth through the mast. The lightning finial shall not be provided on the lantern carriage under any circumstances in view of safety of the system.

Lightning rod at the top of the mast for the lightning protection of the lighting mast system as per standard IS-2309.

Aviation Obstruction Lights:

Aviation Obstruction Lights shall be LED and of reliable design and reputed manufacturer shall be provided on top of each mast.

Low intensity (minimum 10 candela in red, minimum 90 candela luminous intensity – total 360° integrated) red coloured clustered LED type aviation obstruction/warning lights (AOL) shall be provided. The AOL shall be steady glowing (without any flashing). AOL shall have min. 10Cd maintained intensity over a period of >15years. AOL shall be fed from UPS. Remote analogue indication of functioning of all the parallel circuits and lamps shall be provided in Control Room with Alarm Relay. Automatic Bypass system shall be provided, in the luminaire, for series of LEDs of each luminaire. AOL shall be suitable for lamp exchange period of over 15years.

TECHNICAL SPECIFICATIONS M&E

Earthing Terminals:

Suitable earth terminal using 12 mm diameter stainless steel bolts shall be provided at a convenient location on the base of the Mast, for lightning and electrical earthing of the mast.

Earthing For each high mast shall be done with 2nos. of 25mm Dia. 1500mm long GI Earth rod. The 25x6mm GI earth strip shall be run from earth rod to feeder pillar and from feeder pillar to fixture earthing shall be done with 12SWG GI Wire

STANDARD MAST DIMENSIONS:

The high mast sizes / Dimensions mentioned are tentative. However manufacturer standards shall super cede. And in such cases the contractor shall give structural stability for the same. The bottom of the base plate of high mast shall be 300 mm. above the finished ground level.

STANDARD MAST DIMENSIONS

MAST HT (M)	TOP (mm)	BOT DIA (mm)	PLATE THK (mm)	PCD (mm)	FOUNDATION BOLTS	NO. OF FIXTURES
12.5	100/150	360	3	445	M24/850 x 4	6
16	150	410	3,4	490	M30/850 x 8	06/08/10
20	150	460	3,4	590	M30/850 x 8	12/16
25	150	540	3,4,5	650	M30/850 x 12	16
30	150	610	4,4,6	740	M30/850 x 12	16

Feeder Pillar:

Each mast shall be provided with a feeder pillar fabricated out of 14 SWG CRCA sheet and finished with two coats of red oxide primer and grey enamel paint of shade 631 of IS-5. The feeder pillar shall comprise of incoming MCB Isolator, Copper wiring, suitable timer, contactor to switch on the luminaries at a pre-set time. Half of the fixtures shall be switched off after midnight by using 2 nos. of suitable capacity of timers. There shall be suitable control arrangement to change the direction of rotation of the power tool-motor. Feeder pillar shall be mounted on suitable foundation near to the mast.

- (i) Each high mast shall be supplied with one power supply feeder pillar distribution box, which shall be located near it. The feeder pillar-box shall be metal enclosed, double door construction, free standing type made out of 2.5mm CRCA sheet steel, finished with two coats of red oxide primer and grey enamel paint of shade 631 of IS-5 & minimum 80 microns thickness of paint and IP-55 weather

TECHNICAL SPECIFICATIONS M&E

protected. Additional canopy for rain protection shall be provided as an integral part of feeder pillar distribution box. All hardware shall be hot dip galvanized.

- (ii) Tolerance on dimension shall be +0 to +3.
- (iii) The feeder box shall be complete with incomer MCB + RCCB(30mA), motor starters for winch drive, MCB for lighting control, SPP for 3 phase motor if used and a 3 pin5/15A socket along with 15A MCB. MCB and RCCB shall be separate unit.
- (iv) The feeder pillar shall comprise of incoming MCB Isolator, Copper wiring, suitable timer, contactor to switch on the luminaries at a pre-set time. Half of the fixtures shall be switched off after midnight by using 2 nos. of suitable capacity of timers. There shall be suitable control arrangement to change the direction of rotation of the power tool-motor.
- (v) Motor starter shall be complete with MCCB/ MPCB, contactor, and bimetal relay with single phasing prevention feature. Motor Starter shall be suitable for type 2 co- ordination. Type 2 co-ordination charts shall be provided for approval.
- (vi) LEDES for indication of incoming power supply healthy for feeder pillar incomer shall be provided. Feeder pillar shall also have provision to receive emergency power supply for aviation fixtures in case specified in the data sheet.
- (vii) Adequately rated space heater with MCB, thermostat shall be provided for the feeder pillars.
- (viii) Feeder pillar shall have adequate space to receive incoming and outgoing cable terminations for 415V, TPN supply loops in and loop out arrangement. The feederpillar-box shall be complete with double compression nickel-plated brass cable glands and tinned copper lugs.
- (ix) The feeder pillar shall have two numbers external earthing terminal.
- (xi) The feeder pillar-box shall have required wiring interface for taking signals from hand held external control push button station for raising and lowering of lantern carriage. The feeder pillar-box shall be installed on a raised concrete foundation block and foundation shall be up to the level of minimum 300mm above FGL



TECHNICAL SPECIFICATIONS M&E

SP-ME-TS-43 GYMNASIUM EQUIPMENTS:

Gymnasium equipments shall be confirming to following specifications:

- (i) Body Frame: Frames made out of CRCA M.S. Tubular Square of size '50X50 mm'. 14 SWG with epoxy powder coating process standard.
- (ii) Seat: Seats made of approved quality rexine & commercial ply of size 18mm thick & Polyethylene foam.
- (iii) Pulleys: Pulleys will be made of oil cast iron/nylon with epoxy coating powder coating 180 microns.
- (iv) Weight Plates: Made of mild steel with nylon bushes & powder coated.
- (v) Handles: Made of mild steel with smooth bends & provided knurling for proper grip.
- (vi) Rod: Made of mild steel of size 25mm dia. with hard chrome plating.
- (vii) Nuts & Bolts: Made of 4.4 grade M.S. chrome plated.
- (viii) Wire Rope: Made of S.S. with Nylon coating having 6 mm dia. Certificate for S.S. material shall be submitted.
- (ix) Barbell rack: Made of mild steel tubular square of size 25X25mm, 12 SWG, with powder coating.
- (x) Dumbbells Rack: Made of mild steel angle & pipe as per requirement, with epoxy powder coating.
- (xi) Plate Rack: Made of mild steel pipe & rod of suitable size with powder coated.
- (xii) Dumbbells: Made of mild steel with chrome plated or rubber coated as per requirement.
- (xiii) Plates: Made of mild steel with chrome plating or powder coating as per requirement.

SPECIFICATIONS FOR OUTDOOR GYM EQUIPMENTS (OPEN GYM)

1. SS MULTI GYM :

Four vertical posts of the Open Air Multi Gym are made up of 80 x 40 mm rectangular tube of Stainless-Steel material. 25 NB S. S. pipe is placed in between two adjacent vertical posts. Horizontal frame of the Open Air Multi Gym is made up of 100 x 50 mm rectangular tube of Stainless-Steel material. 25 NB S. S. pipes are welded in horizontal frame at equal distance which acts as rungs for the bar. Steel rods welded at different heights for various kinds of exercises. Steel rods have knurling at the hand grips for better gripping. Base stand plate made of mild steel.

2. ABS BOARD SINGLE :

AREA: - 2.0 Mtr x 0.5 Mtr

Safe Area:- 3.5 Mtr x 1.8 Mtr

TECHNICAL SPECIFICATIONS M&E

The main frame Pipe is of 40 and 25 NB B Class G.I. Pipe. Fiber Reinforced Plastic sheet of 3mm thickness is Bounded on 25 NB B class G.I. pipe of main frame. All Nut Bolts are G.I/ M.S./Stainless Steel material. Closing Caps are made up of LLDPE / HDPE /M.S. Nylon cap mounted on pins to protect bearings and pins from rain and dust. The Equipment shall be Powder coated of at least 30-50 microns thickness using Akzonobel /Berger /Prime make or equivalent.

3. AERIAL STROLLER :

AREA :- 1.12 Mtr x 0.35 Mtr

SAFE AREA: 2.12 Mtr x 2.55 Mtr

The main frame pipe is bend from 80 NB B Class GI pipe with 250mm radius. Walker pedal frame duly bend is of 32 NB GI B Class pipe. Air Walker handle frame is of 25 NB GI Pipe duly bend. MS plate of 245 x 113 x 2.8mm for footrest support. Bush made from 60mm dia seamless pipe & 60mm dia Solid bar. The pins used are made up of DIA 25 mm of SAE8620 material. The bearings used are of 6205-2RS1 permanent lubricated sealed bearing of reputed brand. All Nut Bolts are G.I/ M.S./Stainless Steel material. Closing Caps are made up of LLDPE / HDPE /M.S. Nylon cap mounted on pins to protect bearings and pins from rain and dust. The Equipment shall be Powder coated of at least 30-50 microns thickness using Akzonobel /Berger /Prime make or equivalent.

4. AERO RIDER :

AREA:- 1.03 Mtr x 0.7 Mtr

SAFE AREA:- 3.5 Mtr x 2 Mtr

The center pipe is of 100NB made up of B Class G.I. pipe. The handle frame and main frame is made up from 32NB B Class G.I. pipe. The connecting pipe is made up from 25NB B Class G.I. pipe. The seat is fitted on the outer frames are made up of M.S. Sheet of size 330mm X 300 mm X 2mm thickness, deep drawn and pressed with uniform radius of 20 mm and no sharp edges. Bush made from 50mm dia seamless pipe. Pins used of Diameter 17mm are made up from SAE 8620 material. The bearings used are of 6203-2RS1 permanent lubricated sealed bearing of reputed brand. All Nut Bolts are G.I/ M.S./Stainless Steel material. Closing Caps are made up of LLDPE / HDPE /M.S. Nylon cap mounted on pins to protect bearings and pins from rain and dust. The Equipment shall be Powder coated of at least 30-50 microns thickness using Akzonobel /Berger /Prime make or equivalent.

5. BACK EXTENSION :

AREA:- 1.3 Mtr x 0.70 Mtr

SAFE AREA:- 2.5 Mtr x 1.9 Mtr

The frame is made of 32 NB B Class G.I. Pipe. The bottom frame is of 32 NB and Seating support is 50 NB "B" Class G.I. pipe. seating frame is 25 NB "B" class G.I. pipe. The handle frame is of 32NB "B" Class G.I. pipe. The rest seat is fitted on the frame is made up of M.S. Sheet of size 330mm X 300 mmX2mm thickness, deep

TECHNICAL SPECIFICATIONS M&E

drawn and pressed with uniform radius of 20 mm and no sharp edges. The footrests are made from PPCP /Cast Iron. With the support of 250mm X 115mm X 3mm thick MS plate. All Nut Bolts are G.I/ M.S./Stainless Steel material. Closing Caps are made up of LLDPE / HDPE /M.S. Nylon cap mounted on pins to protect bearings and pins from rain and dust. The Equipment shall be Powder coated of at least 30-50 microns thickness using Akzonobel /Berger /Prime make or equivalent.

6. CHEST PRESS + SEATED PULLER :

AREA:- 1.8 Mtr x 0.7 Mtr

SAFE AREA:- 4.8 Mtr x 2 Mtr

The center pipe is of 100NB made up of B Class G.I. pipe. The connecting pipes are made up from 25NB B Class G.I. pipe. The handle frame is made up from 32NB B Class G.I. pipe. The seats and Back rests are fitted on the outer frames are made up of M.S. Sheet of size 330mm X 300 mmX2mm thickness, deep drawn and pressed with uniform radius of 20 mm and no sharp edges. Bush made from 60mm dia seamless pipe & 60mm diameter solid bar bush are used. Pins used of Diameter 25mm and 17mm are made up from SAE 8620 material. The bearings used are of 62052RS1 & 62032RS1 permanent lubricated sealed bearing of reputed brand. All Nut Bolts are G.I/ M.S./Stainless Steel material. Closing Caps are made up of LLDPE / HDPE /M.S. Nylon cap mounted on pins to protect bearings and pins from rain and dust. The Equipment shall be Powder coated of at least 30-50 microns thickness using Akzonobel /Berger /Prime make or equivalent.

7. CHEST PRESS DOUBLE :

AREA: - 1.7 Mtr x 0.7 Mtr

SAFE AREA: - 4.0 Mtr x 2.2 Mtr

The center pipe is of 100NB made up of B Class G.I. pipe. The connecting pipes are made up from 25NB B Class G.I. pipe. The handle frame is made up from 32NB B Class G.I. pipe. The seats and Back rests are fitted on the outer frames are made up of M.S. Sheet of size 330mm X 300 mmX2mm thickness, deep drawn and pressed with uniform radius of 20 mm and no sharp edges. Bush made from 60mm dia seamless pipe & 60mm diameter solid bar bush are used. Pins used of Diameter 25mm and 17mm are made up from SAE 8620 material. The bearings used are of 6205-2RS1 & 6203-2RS1 permanent lubricated sealed bearing of reputed brand. All Nut Bolts are G.I/ M.S./Stainless Steel material. Closing Caps are made up of LLDPE / HDPE /M.S. Nylon cap mounted on pins to protect bearings and pins from rain and dust. The Equipment shall be Powder coated of at least 30-50 microns thickness using Akzonobel /Berger /Prime make or equivalent.

8. CIRCULAR PULL UP STATION :

Product Area : 3.5 X 3.0 Mtr

Safe

Area : 4.5 x 4.0 Mtr

TECHNICAL SPECIFICATIONS M&E

The main frame of Circular Pull up Station is made by combinations of different size frames. The vertical support pipes are made by 80 NB G.I. pipes. This vertical support pipes give supports to horizontal handle bars. All different size horizontal supports are made up of 40 NB G.I. pipes. These different sized horizontal bar supports are attached at different height to the vertical frame. Separate foundation stands made of 80 NB G.I. pipes and G.I. plated M.S. round plates are provided to each support. All pipes are uniformly powder coated up to minimum 60 micron thickness to avoid corrosion. All open ends of pipe been closed by GI /PVC caps for user safety against entrapment.

9. DOUBLE BAR :

Ground Space: 2.05 Mtr x 0.6 Mtr

Safe Play Area: 4.4 Mtr x 1.8 Mtr

This item being from exercise range provides a structure for physical exercise to the children. The complete structure shall be made out using 40 NB B Class GI Pipe. The spacer pipes used shall be of 20 NB B Class GI Pipe. The Equipment shall be Powder coated of at least 30-50 microns thickness using Akzonobel /Berger /Prime make or equivalent.

10. DOUBLE PARALLEL BAR :

AREA:- 1 Mtr x 0.5 Mtr

SAFE AREA:- 2.5 Mtr x 1.8 Mtr

The main frame Pipe is of 100mm NB made from B Class G.I. Pipe. The handle frame are of 25mm NB B class GI pipe. The bottom support is of M.S. round plate of DIA 250 mm & 8 mm thick. All Nut Bolts are Stainless Steel material. Closing Caps are made up of LLDPE / HDPE /M.S. The Equipment shall be Powder coated of at least 30-50 microns thickness using Akzonobel /Berger /Prime make or equivalent.

11. FOREARM TWIRL :

AREA:- 0.5 Mtr x 1.2 Mtr

Safe Area:- 2 Mtr x 3 Mtr

The center pipe is of 100 NB made up of B Class G.I. pipe. The Handle frame is made up of 32 NB 'B' class G.I pipe and the handle movement round frame is made up from 25 NB 'B' class G.I. pipe. Bush made from 60mm dia seamless pipe are used. Pins used of Diameter 25mm and 12mm are made up from SAE 8620 material. The bearings used are of 6205-2RS1 & 6201-2RS1 permanent lubricated sealed bearing of reputed brand. All Nut Bolts are G.I./ M.S./Stainless Steel material. Closing Caps are made up of LLDPE / HDPE /M.S. Nylon bush is used for handle knob and nylon cap mounted on pins to protect bearings and pins from rain and dust. The circlips for locking are A24 & A11. The Equipment shall be Powder coated of at least 30-50 microns thickness using Akzonobel /Berger /Prime make or equivalent.

TECHNICAL SPECIFICATIONS M&E

12. FOREARM TWIRL DOUBLE / TAICHI SP :

AREA:- 0.9 Mtr x 1.2 Mtr

Safe Area:- 2.5 Mtr x 3 Mtr

The center pipe is of 100 NB made up of B Class G.I. pipe. The Handle frame is made up of 32 NB 'B' class G.I pipe and the handle movement round frame is made up from 25 NB 'B' class G.I. pipe. Bush made from 60mm dia seamless pipe are used. Pins used of Diameter 25mm and 12mm are made up from SAE 8620 material. The bearings used are of 6205-2RS1 & 6201-2RS1 permanent lubricated sealed bearing of reputed brand. All Nut Bolts are G.I/ M.S./Stainless Steel material. Closing Caps are made up of LLDPE / HDPE /M.S. Nylon bush is used for handle knob and nylon cap mounted on pins to protect bearings and pins from rain and dust. The circlips for locking are A24 & A11. The Equipment shall be Powder coated of at least 30-50 microns thickness using Akzonobel /Berger /Prime make or equivalent.

13. HD HANGING WHEEL :

AREA:- 2.5 mtr x 0.6 mtr

Safe Area:- 5 Mtr x 1.8 Mtr

The center pipe is of 100 NB made up of B Class G.I. pipe. The Handle frame is made up of 32 NB 'B' class G.I pipe and the handle movement round frame is made up from 25 NB 'B' class G.I. pipe. Bush made from 60mm dia seamless pipe are used. Pins used of Diameter 25mm and 12mm are made up from SAE 8620 material. The bearings used are of 6205-2RS1 & 6201-2RS1 permanent lubricated sealed bearing of reputed brand. All Nut Bolts are G.I/ M.S./Stainless Steel material. Closing Caps are made up of LLDPE / HDPE /M.S. Nylon bush is used for handle knob and nylon cap mounted on pins to protect bearings and pins from rain and dust. The circlips for locking are A24 & A11. The Equipment shall be Powder coated of at least 30-50 microns thickness using Akzonobel /Berger /Prime make or equivalent.

14. HIP TWISTER :

AREA:- 1 Mtr x 0.6 Mtr

SAFE AREA:- 2.9 Mtr x 1.8 Mtr

The center pipe is of 100NB made up of B Class G.I. pipe. The bottom frame is of 32NB "B" class G.I. pipe. The handle frame is of 32NB "B" class G.I. pipe. The twister plate fitted on the bottom frame is made up of M.S. Round Plate of size Dia 300mm and 6mm thick. Bush made from 75mm dia seamless pipe, Pins used of Diameter 35mm are made up from SAE 8620 material. The bearings used are of "6007-2RS1" & "32007" Tapered roller bearing permanent lubricated sealed bearing of reputed Brand. All Nut Bolts are G.I/ M.S./Stainless Steel material. Closing Caps are made up of LLDPE / HDPE /M.S. Nylon cap mounted on pins to protect bearings and pins from rain and dust. The Equipment shall be Powder coated of at least 30-50 microns thickness using Akzonobel /Berger /Prime make or equivalent.

TECHNICAL SPECIFICATIONS M&E

15. HIP TWISTER DOUBLE CIRCULAR :

AREA:- 1.7 Mtr x 0.6 Mtr

SAFE AREA:- 4.2 Mtr x 1.8 Mtr

The center pipe is of 100NB made up of B Class G.I. pipe. The bottom frame is of 32NB "B" class G.I. pipe. The handle frame is of 32NB "B" class G.I. pipe. The twister plate fitted on the bottom frame is made up of M.S. Round Plate of size Dia 300mm and 6mm thick. Bush made from 75mm dia seamless pipe, Pins used of Diameter 35mm are made up from SAE 8620 material. The bearings used are of "60072-RS1" & "32007" Tapered roller bearing permanent lubricated sealed bearing of reputed Brand. All Nut Bolts are G.I/ M.S./Stainless Steel material. Closing Caps are made up of LLDPE / HDPE /M.S. Nylon cap mounted on pins to protect bearings and pins from rain and dust. The Equipment shall be Powder coated of at least 30-50 microns thickness using Akzonobel /Berger /Prime make or equivalent.

16. HIP TWISTER TRIPPLE :

AREA:- 1.4 Mtr x 1.4 Mtr

SAFE AREA:- 5 Mtr x 3.5 Mtr

The center pipe is of 100NB made up of B Class G.I. pipe. The bottom frame is of 32NB "B" class G.I. pipe. The handle frame is of 32NB "B" class G.I. pipe. The twister plate fitted on the bottom frame is made up of M.S. Round Plate of size Dia 300mm and 6mm thick. Bush made from 75mm dia seamless pipe, Pins used of Diameter 35mm are made up from SAE 8620 material. The bearings used are of "6007-2RS1" & "32007" Tapered roller bearing permanent lubricated sealed bearing of reputed Brand. All Nut Bolts are G.I/ M.S./Stainless Steel material. Closing Caps are made up of LLDPE / HDPE /M.S. Nylon cap mounted on pins to protect bearings and pins from rain and dust. The Equipment shall be Powder coated of at least 30-50 microns thickness using Akzonobel /Berger /Prime make or equivalent.

17. LEG EXTENSION :

AREA:- 0.85 Mtr x 0.61 Mtr

SAFE AREA:- 2 Mtr x 1.8 Mtr

The main support is made of 100 NB B Class G.I. Pipe. The frame and moving frame is made from 32 NB B Class G.I. Pipe. The handle frame is of 25NB "B" Class G.I. pipe. The seat is fitted on the frame is made up of M.S. Sheet of size 330mm X 300 mmX2mm thickness, deep drawn and pressed with uniform radius of 20 mm and no sharp edges. Bush made from 60mm dia seamless pipe, Pins used of Diameter 17mm are made up from SAE 8620 material. The bearings used are of "6203-2RS1" permanent lubricated sealed bearing of reputed Brand. Bush made from 60mm dia seamless pipe, Pins used of Diameter 17mm are made up from SAE 8620 material. The bearings used are of "6203-2RS1" permanent lubricated sealed bearing of reputed Brand. All Nut Bolts are G.I/ M.S./Stainless Steel material. Closing Caps are made up of LLDPE / HDPE /M.S. Nylon cap mounted on pins to protect bearings and

TECHNICAL SPECIFICATIONS M&E

pins from rain and dust. The Equipment shall be Powder coated of at least 30-50 microns thickness using Akzonobel /Berger /Prime make or equivalent.

18. LEG LIFT POST :

AREA:- 0.9 Mtr x 0.6 Mtr

SAFE AREA:- 2 Mtr x 2 Mtr

The main frame Pipe is of 100 NB made from B Class G.I. Pipe. The handle frame are of 25 NB & 32 NB B Class GI pipe. All Nut Bolts are G.I/ M.S./Stainless Steel material. Closing Caps are made up of LLDPE / HDPE /M.S. Nylon cap mounted on pins to protect bearings and pins from rain and dust. The Equipment shall be Powder coated of at least 30-50 microns thickness using Akzonobel /Berger /Prime make or equivalent.

19. LEG PRESS SINGLE :

AREA: - 1.7 Mtr x 0.4 Mtr

SAFE AREA: - 2.5 Mtr x 1.5 Mtr

The Center pipe is of 100 NB made from "B" Class G.I. Pipe. The remaining outer frame is of 32mm NB "B" Class G.I. pipe. The seats and Back rests are fitted on the outer frames are made up of M.S. Sheet of size 330mm X 300 mmX2mm thickness, deep drawn and pressed with uniform radius of 20 mm and no sharp edges. The footrest are made from PPCP /Cast Iron material. The frame of footrest made up of 25 NB "B" class G.I. pipe. Bush made from 60mm dia seamless pipe bush are used. Pins used of Diameter 25mm are made up from SAE 8620 material. The bearings used are of "6205-2RS1" permanent lubricated sealed bearing of reputed Brand. All Nut Bolts are G.I/ M.S./Stainless Steel material. Closing Caps are made up of LLDPE / HDPE /M.S. Nylon cap mounted on pins to protect bearings and pins from rain and dust. The Equipment shall be Powder coated of at least 30-50 microns thickness using Akzonobel /Berger /Prime make or equivalent.

20. LEG STRETCH :

AREA:- 1.2 mtr x 0.8 mtr

SAFE AREA:- 2.5 Mtr x 1.8 Mtr

The main frame Pipe is of 100 mm NB made from B Class G.I. Pipe. The handle frame are of 25mm NB B class GI pipe. The bottom support is of M.S. round plate of DIA 250 mm & 8 mm thick. All Nut Bolts are Stainless Steel material. Closing Caps are made up of LLDPE / HDPE /M.S. The Equipment shall be Powder coated of at least 30-50 microns thickness using Akzonobel /Berger /Prime make or equivalent.

21. SEAT AND PEDDLE BIKE :

AREA:- 0.98 Mtr x 0.50 Mtr

SAFE AREA:- 2 Mtr x 1.8 Mtr

TECHNICAL SPECIFICATIONS M&E

The frame is made of 50 NB B Class G.I. Pipe. The handle frame is of 25NB "B" Class G.I. pipe. M.S. drum of Ø300mm & 100mm thickness used to form a paddle assembly. The seat is fitted on the frame is made up of M.S. Sheet of size 330mm X 300 mmX2mm thickness, deep drawn and pressed with uniform radius of 20 mm and no sharp edges. Bush made from 75mm dia seamless pipe, Pins used of Diameter 30mm are made up from SAE 8620 material. The bearings used are of "60062RS1" permanent lubricated sealed bearing of reputed Brand. All Nut Bolts are G.I/ M.S./Stainless Steel material. Closing Caps are made up of LLDPE / HDPE /M.S. The circlips for locking are A29. The Equipment shall be Powder coated of at least 30-50 microns thickness using Akzonobel /Berger /Prime make or equivalent.

22. CROSS TRAINER :

AREA:- 1.08 Mtr x 0.5 Mtr

SAFE AREA: - 3.5 Mtr x 2.0 Mtr

The main frame Pipe is of 80 NB B Class G.I. Pipe with single bend pipe with 250mm radius. The Moving pipe are of 32NB B Class G.I Pipe. The Handle Frame is made up of 25NB B Class G.I. Pipe. Bush made from 60mm dia seamless pipe, Pins used of Diameter 35mm, 25mm, and 17mm are made up from SAE 8620 material. The Bearings used are of 60072RS1 & 62052RS1 and 62032RS1 permanent lubricated sealed bearing of reputed brand. All Nut Bolts are G.I/ M.S./Stainless Steel material. Closing Caps are made up of LLDPE / HDPE /M.S. The circlips for locking are A34, A24 & A16. The Equipment shall be Powder coated of at least 30-50 microns thickness using Akzonobel /Berger /Prime make or equivalent.

23. PEDDLE PUSH :

Product Area : 1m x 0.48m

Safe Play Area : 2m x 1.48m

Ideal For : 13 Years & above

The main frame of Pedal Push is made from 40NB GI Pipe. Handle frame is made from 25NB GI Pipe. Material used for handgrip is EPDM (ethylene propylene diene monomer) Rubber. Footpedal is mounted on the ring of 40NB pipe. High quality Crank shafts and Pedal are used for the Footrest. Bearings are oil sealed, self-lubricated made of SKF/ NTN/ NACHI / FAG / NRB make shall be provided for smooth & trouble-free movement. Bearing Housing shall be made from MS material. Pins shall be made from EN8/ MS material & Circlips made from standard material. The materials used for Seat is FRP/ LLDPE / Metal. All metal pipes are Hot Dipped Galvanized Pipes conforming to IS 1239 (Part 1) with GI thickness of 40-60micron. Medium Duty ('B' Class) or Heavy Duty ('C' Class) Series of pipes only.Wall thickness of pipe varies according to class/series of pipe used. It shall be done with pure polyester raw material. Dry film Thickness maintained within the range of 50-70 microns.it is tested for adhesion test (According to ASTM-D-3359) with the help of cross hatch cutter instruments. Galvanized/ S.S./Allen Bolt/Button Head Allen Bolt & Nuts / Nylon Lock Nuts are used with PVC Bolt Caps. All open ends of pipe been

TECHNICAL SPECIFICATIONS M&E

closed by GI / PVC caps for user safety against entrapment. ISO9001:2015 certificate, Multicolor for optional or customized and as per RAL Shade. Safety 3 layer packaging like 1st EPE Foam 2nd HDPE Film and 3rd is Stretch wrap.

24. PULL UP STATION :

AREA:- 0.9 Mtr x 0.6 Mtr

SAFE AREA:- 2 Mtr x 2 Mtr

The main frame Pipe is of 100 NB made from B Class G.I. Pipe. The handle frame are of 25 NB & 32 NB B Class GI pipe. All Nut Bolts are G.I/ M.S./Stainless Steel material. Closing Caps are made up of LLDPE / HDPE /M.S. Nylon cap mounted on pins to protect bearings and pins from rain and dust. The Equipment shall be Powder coated of at least 30-50 microns thickness using Akzonobel /Berger /Prime make or equivalent.

25. SHOULDER EXERCISER :

AREA: - 1.2 Mtr x 0.7 Mtr

SAFE AREA: - 2.8 Mtr x 2.2 Mtr

The center pipe is of 100NB made up of B Class G.I. pipe. The bottom is welded with support of M.S. round plate DIA 250 mm & 8 mm thickness. The connecting pipes are made up from 25NB B class G.I. pipe. The handle frame is made up from 32NB B class G.I. pipe. The seats and Back rests are fitted on the outer frames are made up of LLDPE /M.S. Sheet of size 330mm X 300 mmX2mm thickness, deep drawn and pressed with uniform radius of 20 mm and no sharp edges. Bush made from 60mm dia seamless pipe & 60mm diameter solid bar bush are used. Pins used of Diameter 25mm and 17mm are made up from SAE 8620 material. The bearings used are of 6205-2RS1 & 6203-2RS1 permanent lubricated sealed bearing of reputed brand. All Nut Bolts are G.I/M.S/Stainless Steel material. Closing Caps are made up of LLDPE / HDPE /M.S. The circlips for locking are A24 & A16. P.U. bush is used as Stopper to avoid the equipment abrasion. The Equipment shall be Powder coated of at least 30-50 microns thickness using Akzonobel /Berger /Prime make or equivalent.

26. SHOULDER EXERCISER DOUBLE :

AREA:- 1.8 Mtr x 0.7 Mtr

SAFE AREA:- 4.8 Mtr x 2 Mtr

The center pipe is of 100NB made up of B Class G.I. pipe. The connecting pipes are made up from 25NB B Class G.I. pipe. The handle frame is made up from 32NB B Class G.I. pipe. The seats and Back rests are fitted on the outer frames are made up of M.S. Sheet of size 330mm X 300 mmX2mm thickness, deep drawn and pressed with uniform radius of 20 mm and no sharp edges. Bush made from 60mm dia seamless pipe & 60mm diameter solid bar bush are used. Pins used of Diameter 25mm and 17mm are made up from SAE 8620 material. The bearings used are of 62052RS1 & 62032RS1 permanent lubricated sealed bearing of reputed brand. All Nut Bolts are G.I/ M.S./Stainless Steel material. Closing Caps are made up of LLDPE

TECHNICAL SPECIFICATIONS M&E

/ HDPE /M.S. Nylon cap mounted on pins to protect bearings and pins from rain and dust. The Equipment shall be Powder coated of at least 30-50 microns thickness using Akzonobel /Berger /Prime make or equivalent.

27. SHOULDER TWIRL / SPINNER :

AREA:- 0.6 Mtr x 0.85 Mtr

SAFE AREA:- 2.4 Mtr x 2 Mtr

The center pipe is of 100 NB made up of B Class G.I. pipe. The handle movement round frame is made up from 25 NB 'B' class G.I. pipe. Bush made from 60mm dia seamless pipe are used. Pins used of Diameter 25mm and 12mm are made up from SAE 8620 material. The bearings used are of 6205-2RS1 & 6201-2RS1 permanent lubricated sealed bearing of reputed brand. All Nut Bolts are G.I/ M.S./Stainless Steel material. Closing Caps are made up of LLDPE / HDPE /M.S. PP Material is used for handle knob and PP cap mounted on pins to protect bearings and pins from rain and dust. The circlips for locking are A24 & A11. The Equipment shall be Powder coated of at least 30-50 microns thickness using Akzonobel /Berger /Prime make or equivalent.

28. SHOULDER TWIRL DOUBLE :

AREA :- 0.8 Mtr x 0.85 Mtr

SAFE AREA:- 3.2 Mtr x 2 Mtr

The center pipe is of 100 NB made up of B Class G.I. pipe. The handle movement round frame is made up from 25 NB 'B' class G.I. pipe. Bush made from 60mm dia seamless pipe are used. Pins used of Diameter 25mm and 12mm are made up from SAE 8620 material. The bearings used are of 6205-2RS1 & 6201-2RS1 permanent lubricated sealed bearing of reputed brand. All Nut Bolts are G.I/ M.S./Stainless Steel material. Closing Caps are made up of LLDPE / HDPE /M.S. PP Material is used for handle knob and PP cap mounted on pins to protect bearings and pins from rain and dust. The circlips for locking are A24 & A11. The Equipment shall be Powder coated of at least 30-50 microns thickness using Akzonobel /Berger /Prime make or equivalent.

29. SINGLE BAR :

Ground Space: 1.6 Mtr x 0.1 Mtr

Safe Play Area: 2.4 Mtr x 2.1 Mtr

The horizontal bar shall be used for the exercise of hands and upper part of the body. The vertical frame shall be fabricated out of 80 NB "B" Class GI Pipe and the horizontal bars of 25 NB "B" Class GI Pipe. The Equipment shall be Powder coated of at least 30-50 microns thickness using Akzonobel /Berger /Prime make or equivalent.

30. SIT UP BOARD :

AREA: - 1.6 Mtr x 0.7 Mtr

TECHNICAL SPECIFICATIONS M&E

Safe Area:- 3.2 Mtr x 1.4 Mtr

The main frame Pipe is of 40 and 25 NB B Class G.I. Pipe. Fiber Reinforced Plastic sheet of 3mm thickness is Bounded on 25 NB B class G.I. pipe of main frame. All Nut Bolts are G.I/ M.S./Stainless Steel material. Closing Caps are made up of LLDPE / HDPE /M.S. Nylon cap mounted on pins to protect bearings and pins from rain and dust. The Equipment shall be Powder coated of at least 30-50 microns thickness using Akzonobel /Berger /Prime make or equivalent.

31. TWIST PRO :

Product Area : 1.2 X 0.8 Mtr

Safe Play Area : 2.2 X 1.8 Mtr

The main frame of Twist Pro consists of 80 NB G.I. pipes with rectangular handle attached on it. Handle pipe is made up of 25 NB G.I. pipe. The seated frame is made from 25NB and 15 NB G.I. pipes which are further attached to round plate which acts as a rotating disc. Rotating disc made from Metal/HDPE is supported over 80NB G.I pipe stand with the help of specially designed heavy duty bearing shaft assemblies. Bearings used are oil sealed, self lubricated made by reputed company. Stands are bolted to main frame with the help of 40NB G.I profile bend pipe. Foundation stands made up of 80 NB G.I. pipes and G.I. plated M.S. round plates are provided. All pipes are uniformly powder coated up to minimum 60 micron thickness to avoid corrosion. All open ends of pipe been closed by GI /PVC caps for user safety against entrapment.

32. SKY WALKER :

AREA:- 1.8 Mtr x 0.9 Mtr

SAFE AREA:- 4 Mtr x 2.1 Mtr

The main frame pipe is bend from 80 NB B Class GI pipe with 250mm radius. Walker pedal frame duly bend is of 32 NB B Class G.I. pipe. The handle frame is of 25 NB B Class G.I. Pipe duly bend. The Footrest are fitted on G.I. Square pipes of 50 X 50 X 3mm. MS plate of 245 x 113 x 2.8mm for footrest support. Footrest made from PPCP /Cast Iron. Bush made from 60mm dia seamless pipe. The pins used are made up of DIA 25 mm of SAE8620 material. The bearings used are of 6205-2RS1 permanent lubricated sealed bearing of reputed brand. All Nut Bolts are G.I / M.S./ Stainless Steel material. Closing Caps are made up of LLDPE / HDPE /M.S. Nylon cap mounted on pins to protect bearings and pins from rain and dust. The circlips for locking are A24. The Equipment shall be Powder coated of at least 30-50 microns thickness using Akzonobel /Berger /Prime make or equivalent.

33. 3 IN 1 (AERIAL STROLLER + LEG PRESS + STANDING TWISTER) :

AREA:- 2.84 Mtr x 0.63 Mtr

Safe area :- 3.85 Mtr x 2.60 Mtr

TECHNICAL SPECIFICATIONS M&E

The center pipe is of 100 NB B Class GI pipe. Walker pedal frame duly bend is of 32 NB B Class G.I. pipe. Air Walker handle frame is of 25 NB GI Pipe duly bend. MS plate of 245 x 113 x 2.8mm for footrest support. Air Walker Footrest made from PPCP /Cast Iron. The twister plate fitted on the bottom frame is made up of M.S. Round Plate of size Dia 300mm and 6mm thick. Bush made from 70mm, 60mm dia seamless pipe & 60mm dia Solid bar are used. Pins used of Diameter 35mm, 25mm and 12mm are made up from SAE 8620 material. The bearings used are 32007 Tapered Roller Bearing, 6007-2RS1, 6205-2RS1 & 6201-2RS1 permanent lubricated sealed bearing of reputed brand. P.U. bush is used as Stopper to avoid the equipment abrasion. All Nut Bolts are G.I / M.S./ Stainless Steel material. Closing Caps are made up of LLDPE / HDPE /M.S. Nylon cap mounted on pins to protect bearings and pins from rain and dust. The circlips for locking are A24. The Equipment shall be Powder coated of at least 30-50 microns thickness using Akzonobel /Berger /Prime make or equivalent.

34. 3 IN 1 (AERIAL STROLLER + LEG PRESS + SURF BOARD) :

Area:- 2.70 Mtr x 1.03 Mtr

Safe Area:- 4.20 Mtr x 3.04 Mtr

The center pipe is of 100 NB B Class GI pipe. Walker pedal frame and leg press frame duly bend is of 32 NB B Class G.I. pipe. Air Walker handle frame is of 25 NB B Class G.I. Pipe duly bend. Moving frame of Surfer is made from 40 NB B Class G.I. Pipe. MS plate of 245 x 113 x 2.8mm for footrest support. Air Walker Footrest made from PPCP /Cast Iron. Surf Board Step made of FRP / Cast Iron. Bush made from 75mm, 60mm dia seamless pipe & 60mm dia Solid bar are used. Pins used of Diameter 25mm and 12mm are made up from SAE 8620 material. The bearings used are of 6007-2RS1, 6205-2RS1 & 6201-2RS1 permanent lubricated sealed bearing of reputed brand. P.U. bush is used as Stopper to avoid the equipment abrasion. All Nut Bolts are G.I / M.S./ Stainless Steel material. Closing Caps are made up of LLDPE / HDPE /M.S. Nylon cap mounted on pins to protect bearings and pins from rain and dust. The circlips for locking are A24. The Equipment shall be Powder coated of at least 30-50 microns thickness using Akzonobel /Berger /Prime make or equivalent.

35. 3 IN 1 (AERIAL STROLLER + SURF BOARD + SHOULDER TWIRL) :

Area:- 2.13 Mtr x 1.03 Mtr.

Safe Area:- 4.33 Mtr x 2.34 Mtr

The center pipe is of 100 NB B Class GI pipe. Walker pedal frame duly bend is of 32 NB B Class G.I. pipe. Air Walker handle frame is of 25 NB B Class G.I. Pipe duly bend. Moving frame of Surfer is made from 40 NB B Class G.I. Pipe. MS plate of 245 x 113 x 2.8mm for footrest support. Air Walker Footrest made from PPCP /Cast Iron. Surf Board Step made of FRP / Cast Iron. Bush made from 75mm, 60mm dia seamless pipe & 60mm dia Solid bar are used. Pins used of Diameter 25mm and 12mm are made up from SAE 8620 material. The bearings used are of 6007-2RS1, 6205-2RS1 & 6201-2RS1 permanent lubricated sealed bearing of reputed brand. P.U. bush is used as Stopper to avoid the equipment abrasion. All Nut Bolts are G.I /

TECHNICAL SPECIFICATIONS M&E

M.S./ Stainless Steel material. Closing Caps are made up of LLDPE / HDPE /M.S. Nylon cap mounted on pins to protect bearings and pins from rain and dust. The circlips for locking are A24 & A11. Spinner knob made of PP Material. The Equipment shall be Powder coated of at least 30-50 microns thickness using Akzonobel /Berger /Prime make or equivalent.

36. 6 IN 1 MULTI GYM (C CLASS) :

Area : Dia 4.3 mtr

Safe Play Area : Dia 6.3 mtr

The main pipe is of 100mm NB C Class GI pipe. The main frame Pipe of air walker is of 80mm NB C Class G.I. Pipe with single bend pipe with 250mm radius. Walker pedal frame, leg press moving frame, Chest Press Handle frame and twister connecting pipe are duly bend of 32mm NB C Class G.I. pipe. Air Walker handle frame push up bar frame, twister handle, main structure connecting frame, chest press connecting pipes are of 25mm NB C class G.I. Pipe duly bend. Moving frame of Surfer is made from 40mm NB C class G.I. Pipe. The connecting pipes of seated puller are made up from 25NB C class G.I. pipe. MS plate of 245 x 113 x 2.8mm for footrest support. Bush made from 75mm, 60mm dia seamless pipe & 60mm dia Solid bar are used. Pins used of Diameter 35mm, 25mm and 17mm are made up from SAE 8620 material. The bearings used are 32007 Tapered Roller Bearing, 6007-2RS1, 6205-2RS1, 6203-2RS1 & permanent lubricated sealed bearing of reputed brand. P.U. bush is used as Stopper to avoid the equipment abrasion. All Nut Bolts are G.I/ M.S/ Stainless Steel material. Closing Caps are made up of LLDPE / HDPE /M.S. Nylon cap mounted on pins to protect bearings and pins from rain and dust. The circlips for locking are A16 & A24. The Equipment shall be Powder coated of at least 30-50 microns thickness using Akzonobel /Berger /Prime make or equivalent.



TECHNICAL SPECIFICATIONS M&E

SP-ME-TS-44 BOREWELL:

1) Geographic Survey:-

Survey & Scanning of land for ground water comprising of depth wise classification of water bearing strata location at best of depth of ground water spot, complete with transportation of equipment / material at sites, including labour charges & submission of "survey report" in detail for providing bore well shall be carried out for each bore well.

2) Erection of rig:-

The erection of rig, leveling of pre determined spot complete with transportation of material / equipment with labour shall be carried out.

3) Drilling of bore well:-

The contractor shall drill 100/150 mm. dia. of bore up to any depth as per site condition as instructed by M.C.G.M. authorities. The bore shall be drilled in all type of strata up to suitable depth to get sufficient quantity & quality water. All equipment, Labours, water & electricity required for drilling of bore well at site with transportation shall be arranged by contractor. The contractor shall carry out the drilling during day time only, for avoiding noise complaints from the residents nearby and complete the drilling work before 7.00 P.M. The entire work of drilling of bore wells shall be completed within one week.

4) Flushing Testing of bore well:-

The contractor shall carryout flushing of bore well & conduct water yield test of bore well in liters / hour. It shall be measured by means of 90 degree "V" notch by air lift method. The approx. yield in liters / hour shall be indicated after taking yield by "V" notch & airlift method for continuous 3 hours. The yield test for poor yield shall be conducted by hand pump / electric pump for which no extra payment will be made.

If the yield from the bore is less than 10000 liter per day, the same will be treated as dry borewell & no any payment will be made for the dry bore well. The decision to discard the bore well will be entirely at the discretion of M.C.G.M. authorities and its decision shall be final and binding to contractor.

5) Installation of casing pipes:-

The contractor shall provide 140/180 mm dia. P.V.C. ISI mark IS 4985 Class – II 4kg/cm² or M.S. E.R.W.(14 gauge) casing pipe as per bore well size, complete with coupling, cutting in required size, threading, joining and installing by lowering in the bore well up to sufficient level & grouting the same. The casing pipe shall be fixed with 2 pairs of bore well supporting M.S. clamp sets of size 15" with suitable nuts, bolts & washers with approved arrangements. The bore well shall be closed for safety by suitable size 4"/6" C.I. Cap.

6) Construction of Inspection Chamber / water Table:-

The contractor shall excavate the surrounding earth to construct brick masonry rectangular inspection chamber of size 90 x 45 cm. & suitable depth on bore well with 230 mm Brick wall. It shall be plastered on both side with cement mortar(a:2) including 230 mm cement concrete in ration 1:2:4 in haunches for bore for installing elect. Pump. The contractor shall provide C.I. Cover & frame for inspection Chamber. Or Construction of round water platform (water table) with foundation for hand pump & drainage arrangement, drain notch in case for installation of hand pump set as instructed by M.C.G.M. authorities. The work includes complete excavation, refilling excavated site, refilling the surplus earth & leveling properly.

7) Supply Installation Testing & Commissioning of submersible electric pump set:

The contractor shall carryout the work of supply, Installation, testing & commissioning of suitable bore well submersible electrical pump set per I.S.I. for each bore well. The Pump set shall be Water Man / Crompton / Calama / Aroma make. The pump shall be multistage submersible pump set. The discharge of Pump set shall be 20-80 LPM and Head 100-80 mtrs. respectively. & must be 120% of actual yield as per IS: 8034. The submersible electric pump set shall be suitable to work on 440 V, 3 phases or 230 V, 1 phase 50 cycles A.C. Supply as per electric supply as site condition. The Submersible pump shall be lowered in the bore well up to maximum depth as instructed by M.C.G.M. authorities as per site condition. The contractor shall give satisfactory working test of pump set in presence of concerned ward representative.

Control panel:-

The contractor shall provide suitable wall mounting type control panel along with necessary 30/32 Amps, 440V, TPNIC /D.P.I.C. switch fuse unit on angle Iron frame work. The Control panel shall be fabricated with 18 SWG C.R.C.A. sheet & shall be painted with anti corrosive treatment and approved shade powder coating. The control panel shall be comprising with voltmeter 0 to 500 volts, Ammeter (range-0 to 20/30 Amps.) with switch, single phase preventer, suitable rating fully automatic D.O.L. starter, control switch, overload relay, Automatic Water level control pump control system with required sensor wires and Indicator sensor wires and Indicator lamps complete with testing & commissioning pump sets.

Cable:-

- (i) Supply & laying of ISI mark 1.1KV, Grade PVC, insulated copper conductor armoured cable of 4 core x 2.5 sq.mm. size from control panel to submersible pump set up to ground level.
- (ii) Supply & Laying of ISI mark 3 core x 2.5 sq.mm. PVC Insulated & PVC sheathed copper conducted flat cable.
- (iii) Supply & Laying of ISI mark 1.5 sq.mm. Single core, with annealed bare solid & stranded copper conductor PVC. Insulated unsheathed cable for water level sensor.

TECHNICAL SPECIFICATIONS M&E

Laying of Cables:-

The cable shall be fixed on wall & ceiling by means of G.I. Saddles/Clamps of 18/22 SWG 25 mm width G.I. strips. Any single cable to be run on walls & ceiling shall be provided with G.I. Spacers. The cable shall be fixed by G.I. spacers by means of G.I. Sheets saddles. The cable shall be terminated through Lugs & Cable Gland only. The cable shall be covered upto 2 mtrs. by using G.I. pipes/G.I. 18G. C" section G.I. sheet covering for vertical runs at all junctions above ground level.

The cable shall be laid under ground by using sand cushioning in the trenches as per site condition.

The cable shall be laid in one-piece length without joints.

Trenches shall be made for lying under ground cable by excavating the earth, breaking all types of layers, if any and the same shall be refilled with soft earth after the cable is laid in approved manner i.e. by using sand & bricks the trenches shall be made well as surrounding. All the cost of laying cable is included in the cost of cable.

Plumbing:

The contractor shall provide necessary required G.I. piping with other accessories required for installation of pump sets. Supply and laying 'C' class G.I. pipe for delivery line of 40 mm dia / 30 mm dia. NB, from flanged outlet of submersible pump set to delivery point as directed. Plumbing work of water outlets at different points with 40 mm dia. / 30 mm dia. Brass / gunmetal gate valves shall be carried out as directed.

The pipes shall be heavy duty "C" Class quality shall be selected from G.I. Pipes with I.S.I. marks only.

The successful contractor shall submit survey Report & water yield test report.

The payment of drilling bore well, Casing pipes, Pump set, Cable & G.I. pipes & fitting will be made on actual measurement as per schedule of quantity.

Any other material other than schedule of quantity required for complete work of construction of bore well & satisfactory S.I.T.& C. of bore well pump shall be arranged by contractor without any extra cost.



TECHNICAL SPECIFICATIONS M&E

SP-ME-TS-45 HANDPUMP

Stroke Length: 125+45mtr.

Duty : Suitable for use in bore wells having water level ranging from 12 mtrs. to 45mtrs.

Discharge: 17 litres per minutes of 40 strokes

Construction:

- (i) Conversion Head: Side plate, back plate, front end top and bottom end plates shall be made from 4 mm thick MS plates and Bottom flange from 6 mm thick MS plate.
- (ii) Handle: Made from 32 mm square MS bar. Length of Handle 1170 mm. It shall be designed for ease of operation.
- (iii) Chain Assembly: 7 pitch chain assembly welded with M 12 internal threaded couple
- (iv) Cover: Made from 2 mm CR sheet.
- (v) Water Chamber: Top & bottom flanges shall be made from 6 mm thick MS plates. Pipe used in 150mm N.B. Medium class pipe. The riser pipe holder shall be made up of solid bars to hold 32 mm Riser pipes.
- (vi) Stand: The stand flange shall be made from 6 mm thick MS plate. The pipe used shall be 150 mm medium 'B' class pipe and the angles shall be 40x40x6mm
- (vii) Connecting Rod: 12mm dia. MS Bright rod in 3 meter length welded with coupler and half coupler electro galvanised.
- (viii) Cylinder : 53.5 mm I.D. Cast iron cylinder with brass liner and cast iron caps of 32 mm thread with two rubber cup washer(leather) and plunger rod as per IS 9301-1984. The rubber parts in the cylinder shall be non-toxic and hence they shall cause no health hazards.
- (ix) Riser Pipe: 32mm Nominal bore galvanised iron pipe of medium class.

The pump body shall be hot-dipped galvanised hence corrosion proof.

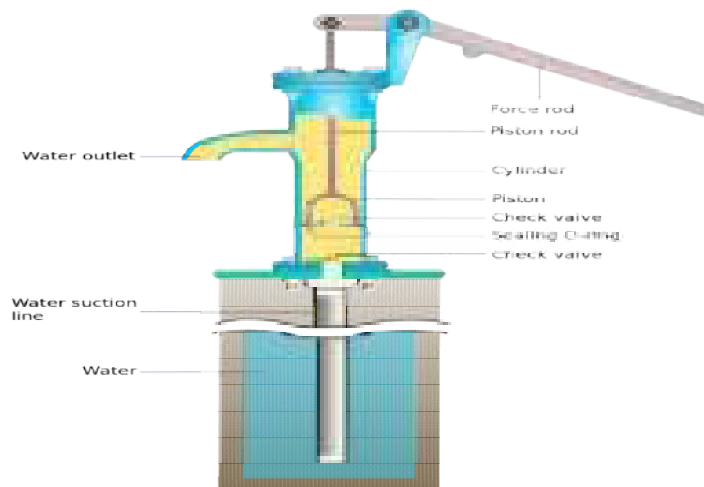

TECHNICAL SPECIFICATIONS M&E

SP-ME-TS-46 SOLAR WATER HEATING SYSTEM:

Scope of work includes supply, installation, testing and commissioning of Solar water heating system with/without heat exchanger for cold and warm region with solar flat plate collector (FTC) / evacuated tube collector(ETC) conforming to IS 12933 latest edition suitable for inlet water with chlorine and fluorine content up to 100ppm and supply of hot water at the outlet.

Solar water heating system shall include solar FTC/ETC, collector stand assembly, stainless steel insulated hot water tank with heat exchanger and various other components.

Solar Flat plate collector-

Sr.No.	Particular	Technical requirement
1	Rated capacity in liters per day LPD	100 / 125 / 200 LPD as specified [Water holding capacity of tank must be equal to the system capacity with maximum permissible variation of 5% calculation
2	Size of solar flat plate collector (Area in sq m)	As per IS 12933
3	Length x width x thickness in cm	To be specified by bidder
4	Dry weight in kgs Collector box frame	To be specified by bidder
5	Material	The collector box shall be made of Aluminium sections. Type, grade, size, workman ship and finish of the material shall be as per IS 12933. Minimum thickness of Al shall be as under- a) Channel Section for side - 1.6mm b) Sheet for bottom - 0.7mm c) Support for glass retaining - 1.2mm d) Sheet for entire body - 1.0mm
6	Section used and their sizes	Minimum thickness of the material shall be given below: i) Aluminium: a) Channel Section for side - 1.4mm b) Sheet for bottom - 0.45mm c) Support for glass retaining - 1.2mm d) Sheet for entire body - 1.0mm ii) Fibre Glass - 3.0mm iii) Galvanized/stainless steel sheet - min 0.60mm iv) CRCA - min 0.6mm
7	Insulation material	Insulation shall be provided at back and sides. Thermal Resistance (R) of insulation material shall be minimum 0.96 m square degree C/W for back insulation and minimum 0.48 m square degree C/W for side insulation. This shall be derived after determining thermal conductivity (K) value at 100 degree C mean temperature in accordance with IS:3346. Collector box insulation shall conform to sec.4 of IS: 12933(pt-

TECHNICAL SPECIFICATIONS M&E

8	Cover plate	Cover plate shall be toughened glass and thickness of 4.0 mm (min.) conforming to section-1 of IS: 12933(pt-2)/2003. The solar transmittance of the cover plate shall be minimum 82 percent at near normal incidence.
9	Absorber Material	Sheet for absorber shall be made of copper with proper protective coating. Type, grade, size, workmanship and finis of the material used shall be as per sectiob-3 of IS:12933 (pt-2)/2003. A sample piece of the absorber for having minimum area of 400 square cm. shall be heated in an oven at temperature of 175 degree C for 2 hours. After heating, the sample shall be taken out from the oven and cooled at room temperature. The cooled sample shall be inspected visually for damages, if any. There shall not be any appearance of blistering/rupture/peeling off of the coated/painted surface and of weakening of the bonding between absorber sheet and risers/headers.
10	Absorber Thickness mm (min)	The thickness of the sheet shall be chosen as to ensure adequate strength and stability against the pressure to prevent swelling, distortion or ruptures.
11	Riser and Header tubes	Absorber shall consist of riser, header and sheet for absorber. The Diameter of header shall be 25.4 +/- 0.5mm and thickness 0.71mm. The diameter of riser shall be 12.7 +/- 0.5mm and thickness 0.5mm and made of copper only. The distance between the risers from center to center shall be 120 mm. Type grade, size, workmanship and finish of the material used shall be as per section-3 of IS:12933 (pt-2)/2003. Riser and header assembly designed for working pressure up to 24.5 K Pa (2.5kg/cm square) shall be tested for leakage at a minimum hydraulic pressure of 490 k Pa (5 Kg/cm square).

	HOT WATER STORAGE TANK	
12	Material	Insulated hot water storage tank shall be non- pressure type and made of stainless steel grade (X04Cr19Ni9 or X07Cr18Ni9 of IS:1570(part 5)/1985.
13	Welding material	TIG welded.

TECHNICAL SPECIFICATIONS M&E

14	Insulation and cladding	Solar water heating system (SWHS) up to and including 500 LPD shall be insulated with 40mm thermal grade PUF insulation of 32 Kg/ meter cube or higher density. PUF insulation could be pre extruded type fitted with FRP exterior cladding or alternatively injection moulded in a twin walled steel tank and PPE end cap. Other systems shall be insulated with 100mm thick Rock wool of 48Kg/m3 density with 24swg Aluminium cladding. Systems up to 500 LPD may also alternatively be installed with 100 mm thick Rock wool of same specifications with aluminium or G.I.powder coated cladding
15	Thickness of tank	The thickness of the water storage tank shall be min 0.5 mm for capacities upto 200 liter and of higher thickness beyond 200 liter capacity
16	Stand Assembly	Shall be made of MS angle of size (min) 38x38x4 mm duly pre-treated and stove enamelled with black Colour paint. Alternatively tubular structure with Powder coating could also be provided.
17	System Interconnecting Piping	ISI marked G.I. pipes, medium class of IS:1239 duly insulated with 50mm thick rock wool of 48 Kg/m3 density and 26swg Al cladding . EPDM hose pipes can also be used for systems up to and including 500 LPD. .
18	Heat Exchanger Accessories	Heat exchanger shall be cage type and made of copper tubes of grade as per IS: 1570(part 5)/1985(Reaffirmed 2004). Heat exchangers shall have a minimum of 0.24 sq. meters heat transfer area per 100 LPD capacity.
19	Sacrificial Anode:	Size, Make, Model and end connections. Aluminium type 1/2", 3/4" with suitable chemical treatment for protection against corrosion
20	Make up tank	(litters) Capacity and material. Suitable capacity of make up tank may be used. Minimum of 1 lit upto 500 lpd. And material stainless steel tubes of grade as per IS: 1570 (part 5)/ 1985 (Reaffirmed 2004)
21	Valves -	Valve for inlet, outlet and make up tank each
22	Electrical heater back up -	Electrical heater shall be ISI marked. Electrical heater back up shall be two nos. each of rating 3kW for 500LPD as per IS 4159 standard.
23	Temp. Gauge	(ISI marked) Dial type with temp range 0-120°C. Optional (not required) upto 500 LPD

TECHNICAL SPECIFICATIONS M&E

Evacuated Tube collector-

Sr. No.	Particulars	Technical requirements
1.	Rated capacity in liters per day LPD	100 / 125 / 200 LPD as per requirement [Water holding capacity of tank must be equal to the system capacity with maximum permissible variation of 5% calculation. Volume of water in collector or evacuated tube & manifold should not be added for system capacity calculation].
2.	Total absorber area (Area in sq m)	As per MNRE rules
3.	Tube size Length x dia x thickness in cm	As per the requirement and conforming to MNRE rules
4.	No of tubes per system	As per MNRE rules
Evacuated Tubes		
1.	Type of glass	3.3 borosilicate glass
2.	Thickness of glass tube	1.6mm (+/- 0.1 mm)
3.	Thermal coefficient of expansion of glass	$3.3 \times 10^{-6} / ^\circ\text{C}$
4.	Selective coating type	Single target
5.	Selective coating contents	AL-N/AL (Single target)
6.	Thickness of coating	350 nm
7.	Solar absorption	92%
8.	Solar Emissivity	7%
9.	Insulation	Vacuum jacket
10.	Pressure - vacuum	$\leq 5 \times 10^{-2}$ Pa
11.	Tube diameter	47 mm (+/- 5mm)
12.	Tube length	1500 mm (+/-5mm)
Manifold Assembly		
	Manifold inner tank diameter	Size and shape of inner tank shall be selected in such a way to accommodate the tubes on both sides. Manifold tank shape can be round or rectangular. If rectangular minimum size shall be 90mm (height) X 130 mm (width)

TECHNICAL SPECIFICATIONS M&E

1.	Manifold inner tank material	SS 304 with antirust coating Min thickness of tank & side dish 0.5 mm of SS - 304 L or SS -316 L
2.	Manifold outer tank diameter	240 mm, Size and shape of outer tank shall be according to the size of inner tank & insulation thickness.
3.	Manifold outer tank material	Pre-coated steel
4.	Insulation	Injected PUF
5.	Insulation Thickness	30 mm
6.	Total no. of tubes in one manifold	No. of tubes in one manifold may vary as per size of tube & system capacity. However, the absorber area requirement should match to MNRE present guidelines.
7.	Gasket for tubes	Silicon rubber
8.	End Connections	3/4 "or 1 " BSP upto 500 lpd
9.	Mounting stand for manifold	Structural steel with polyester coating
10.	Hardware	Stainless Steel - SS 304
HOT WATER STORAGE TANK		
1.	Material	Insulated hot water storage tank shall be non-pressure type and made of stainless steel grade SS 304 (X04Cr19Ni9 or X07Cr18Ni9 of IS:1570(part 5) 1995
2.	Welding material	TIG welded.
3.	Insulation and cladding	Solar water heating system (SWHS) up to and including 500 LPD shall be insulated with 40mm thermal grade PUF insulation of 32 Kg/ meter cube or higher density. PUF insulation could be pre extruded type fitted with FRP exterior cladding or alternatively injection moulded in a twin walled steel tank and PPE end cap. Other systems shall be insulated with 100mm thick Rock wool of 48Kg/m3 density with 24swg Aluminium cladding. Systems up to 500 LPD may also alternatively be installed with 100 mm thick Rock wool of same specifications with aluminium or G.I. powder coated cladding.
4.	Outer Cladding / Cover	Outer cladding cover material should be SS304 coated sheet of UV stabilised thickness should be used
5.	Thickness of tank	The thickness of the water storage tank shall be min 0.5 mm upto 500 lpd as per present guide lines of MNRE.

TECHNICAL SPECIFICATIONS M&E

6.	Stand Assembly	Shall be made of MS angle of size (min) 38x38x4 mm duly pretreated with corrosion resistant protective coating. Alternatively tubular / GI FOLDED structure of size 30x30x1.5 mm with corrosion resistant protective coating / structure with CRCA 35x35x2mm powder
7.	System Interconnecting Piping	ISI marked G.I. pipes, medium class of IS:1239 duly insulated with 50mm thick rock wool of 48 Kg/m ³ density and 26swg Al cladding. EPDM hose pipes can also be used for systems up to and including 500 LPD.
8.	Heat Exchanger	Heat exchanger shall be cage type and made of copper tubes of grade as per IS: 1570(part5)/1985(Reaffirmed 2004). Heat exchangers shall have a minimum of 0.24 Sq. Meters heat transfer area per 100 LPD capacity.
	Accessories	
1.	Sacrificial Anode:	Size, Make, Model and end connections. Aluminium type 1/2", 3/4" with suitable chemical treatment for protection against corrosion
2.	Make up tank	Capacity (liters) and material. - Suitable capacity of makeup tank may be used. Minimum of 1 lit up to 500 lpd. And material stainless steel tubes of grade as per IS: 1570 (part 5)/ 1985 (Reaffirmed 2004)
	Valves -	Valve for inlet, outlet and make up tank each
	Electrical heater backup -	Electrical heater shall be ISI marked. Electrical heater back up shall be two nos. each of rating 3kW for 500LPD as per IS 4159 standard.
	Temp. Gauge	(ISI marked) Dial type with temp range 0-120°C .Optional (not required) up to 500 LPD
	Tube Resting Cap	EPDM rubber
	Silicon Seal	Silicon with 180°temperature withstanding capacity may be used

SP-ME-TS-47 SPECIFICATION FOR THE PLAY APPARATUS: -

1) DELUXE SLIDE 1.5 MTR



REC. AGE: - 4 - 12 YRS.

THE AREA: - 4.5 M X 0.7 M

SAFE PLAY AREA: - 5.5 M X 1.7 M

HEIGHT: - 1.5 M

This item consists of ISI marked structure. The attractive deluxe SS slide chute shall be made in SS. The stainless steel shall be of 304 grades with 16 SWG. The structure comprises of 20- and 25-mm NB "B" Class G.I. pipe. The centre support shall be made in 80mm NB "B" Class G.I. pipe. The ladder cum railing shall be made up of 20- and 25-mm NB "B" Class G.I. Pipe. The platform shall be made up of 14 SWG GI sheets with anti-skid for firm foot grip. There shall be triangular steps of 16 SWG GI sheets. The chute has its end such as it causes safe landing of the child.

2) DELUXE SLIDE 2.1MTR



REC. AGE: - 4 - 12 YRS.

THE AREA: - 4.5 M X 0.7 M

SAFE PLAY AREA: - 5.5 M X 1.7 M

HEIGHT: - 2.1 M

TECHNICAL SPECIFICATIONS M&E

This item consists of ISI marked structure. The attractive deluxe SS slide chute shall be made in SS. The stainless steel shall be of 304 grades with 16 SWG. The structure comprises of 20- and 25-mm NB "B" Class G.I. pipe. The canter support shall be made in 80mm NB "B" Class G.I. pipe. The ladder cum railing shall be made up of 20- and 25-mm NB "B" Class G.I. Pipe. The platform shall be made up of 14 SWG GI sheets with anti-skid for firm foot grip. There shall be triangular steps of 16 SWG GI sheets. The chute has its end such as it causes safe landing of the child.

3) WAVE SLIDE 1.5 M



REC. AGE: - 4 – 12 YRS.

THE AREA: - 4.8 M X 0.5 M

SAFE PLAY AREA: - 5.8 M X 1.5 M

HEIGHT: - 1.5 M

The attractive wave slide chute shall be made up of 4 mm thick FRP (Fibber Reinforced Plastic) / LLDPE (Low linear Density Poly Ethylene) materials. The structure shall comprise of 20- and 25-mm NB 'B" Class GI Pipes. The canter support shall be made in 80 mm NB 'B" Class GI Pipes. The ladder cum railing shall be made 20 mm and 25 mm NB 'B" Class GI Pipes. The platform shall be made up of 14 SWG GI sheet with anti-skid for firm foot grip. There shall be triangular steps 16 SWG GI sheet. The chute shall have its end such as it causes safe landing of the child. The pipes shall be powder coated to prevent rusting.

4) WAVE SLIDE 2.1 M



REC. AGE: - 4 – 12 YRS.

THE AREA: - 4.8 M X 0.5 M

SAFE PLAY AREA: - 5.8 M X 1.5 M

HEIGHT: - 2.1 Mtr

The attractive wave slide chute shall be made up of 4 mm thick FRP (fibre Reinforced Plastic) / LLDPE (Low linear Density Poly Ethylene) materials. The structure shall comprise of 20- and 25-mm NB 'B' Class GI Pipes. The canter support shall be made in 80 mm NB 'B' Class GI Pipes. The ladder cum railing shall be made 20 mm and 25 mm NB 'B' Class GI Pipes. The platform shall be made up of 14 SWG GI sheet with anti-skid for firm foot grip. There shall be triangular steps 16 SWG GI sheet. The chute shall have its end such as it causes safe landing of the child. The pipes shall be powder coated to prevent rusting.

5) ANIMAL MERRY GO ROUND

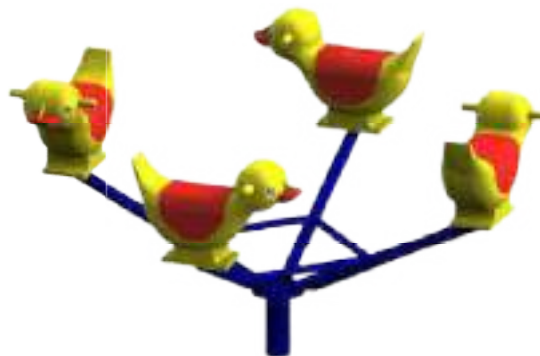

REC. AGE: - 3 - 12 YRS.

THE AREA: - 1.5 M Dia.

SAFE PLAY AREA: - 2.5 M Dia.

The main frame of the animal merry go round shall be made up of 25 & 40 NB 'B' Class GI Pipes. The stand shall be made in 80 NB 'B' Class GI Pipes. The whole structure shall be mounted on heavy-duty bearing shaft permanently lubricated with water sealant. The animal

TECHNICAL SPECIFICATIONS M&E

shall be made out of FRP (fibre Reinforced Plastic) /LLDPE (Low linear Density Poly Ethylene). It shall accommodate 4 children at a time. The pipes shall be powder coated to prevent rusting.

6) SPIRAL SLIDE 2.1 MTR HT.



Spiral slide shall be chute made of FRP (fibre Reinforced Plastic) / LLDPE (Low linear Density Poly Ethylene) having thickness of 4 mm. Slide Centre support shall be 80 mm NB „B” class GI pipe. Landing module shall be supported by 20 mm NB „B” class GI pipe. Slide extension platform shall be made from FRP (fibre Reinforced Plastic) / LLDPE (Low linear Density Poly Ethylene). The railing shall be made from 15 mm NB and 20 mm NB „B” class GI pipe. All pipes shall be powder coated to avoid rusting.

7) ROLLER SLIDE 2.1 MTR. HT.



The most attractive of its kind, the chute of this slide shall consist of plastic rollers. The rollers shall be made up of High-Density Polyethylene Plastic (HDPE) with UV stabilized. Roller’s rod shall be made from 12 mm die bright rod and nylon bush fitted in Rollers for smooth rotation. The main frame shall be made up of M.S angle 50 x 50 x 5 and MS flat 50 X 3. The handrail shall be made in 25 mm NB GI „B” class pipe. The triangular steps provided shall be made out of 16 SWG GI sheet for firm grip and safety. H” support shall be made from 25 mm NB „B” class GI pipe and 25 x 10 MS flat. All pipes, angle and flat shall be powder coated to avoid rusting.

8) DOUBLE SWING WITH BELT ASSEMBLY



The leg support of this item shall be made up of 40 mm NB GI 'B' class pipe while the top bar shall be of 50 mm NB GI " B" class pipe. Leg pipe and top bar shall be attached with junction box which shall be made of 4 mm MS plate with GI plating. Two swings shall be made from 10 mm thick anti-skid chequered reinforced rubber or melded seat, which shall be suspended with rubber coated 6 dia. GI chain. The ball bearings shall be mounted inside a specially designed nylon clamp. The GI pipes shall be powder coated to avoid rusting

9) MULTI SEATER SEE SAW



REC. AGE: - 3 - 10 Yrs.

THE AREA: - 3 M X 0.5 M

SAFE PLAY AREA: - 4 M X 1.5 M

This item shall be a good entertainment for the children. The lever of the see- saw shall be made from 80 mm NB "B" Class G.I. Pipe. See saw seat shall be made of FRP (fiber Reinforced Plastic) / LLDPE (Low linear Density Poly Ethylene) 2 mm thickness. The lever shall be fitted on 50 mm NB "B" Class G.I. Pipe and Bush Bearing shall be made from smiles pipe fitted in 80 mm NB "B" Class G.I. Pipe. See saw lever shall be welded with 200 x 150 x 5 MS plate for Nut bolting with stand. All pipes, flat shall be powder coated to avoid rusting.

10) DOUBLE ARCH SWING



REC. AGE: - 4-14 Yrs.

THE AREA: - 3 M X 1.5 M

SAFE PLAY AREA: - 4 M X 3.5 M

The arch shaped side frame shall be made of 80 mm NB „B” class GI pipe and top pipe shall be made up of 50 mm NB „B” class GI pipe. The frame shall be powder coated to give an aesthetic look. The swing shall be made up of 10 mm thick anti-skid rubber top the rubber belt seat shall be suspended on 6 mm rubber coated GI chain. The ball bearings shall be mounted inside a specially designed nylon clamp.

11) TODDLER SWING



REC. AGE: - 3-8 Yrs.

THE AREA: - 2.8M x 1.

TECHNICAL SPECIFICATIONS M&E

0M SAFE PLAY AREA: - 4.0M x 2.0M

In this toddler swing the canter support shall be made up of 100 mm NB "B" Class G.I. Pipe. The horizontal bars shall be made up of 50 mm NB "B" Class G.I. Pipe. All GI pipes shall be powder coated. Between the two horizontal bars there shall be a heavy-duty metal clamp attached to it. The bucket seats of the toddler swing shall be made of rubber with anti-skid. The ball bearings shall be mounted inside specially designed nylon balls. The rubber seat shall be affixed on 6 mm the GI chain. The seats shall be made with full care so that the child does not fall from it while swinging.

12) FRP / ROTO DELUXE PLAIN SLIDE HT. 1.5 MTR



Ground Space: 4.0 Mtr x 0.6 Mtr

Safe Play Area: 6.2 Mtr x 1.6 Mtr

Structure, ladder & Platform: The centre pipe is of 80 NB B Class GI pipe. Ladder frame duly bend is of 25 NB & 20 NB GI B Class pipe. Platform is made of 14 SWG GI sheet with Anti-Skid design for firm foot grip. Triangular Steps are of 16 SWG GI sheet. Slide Chute: Deluxe Slide Chute is made from 6-7 mm thick fiber Reinforced Plastic (FRP) material. Caps, Nut Bolts: All Nut Bolts are G.I / M.S/ Stainless Steel material. Closing Caps are made up of LLDPE / HDPE /M.S. Nylon cap to protect from rain and dust. Powder Coating: The Equipment shall be Powder coated of at least 30-50 microns thickness using AkzoNobel /Berger /Prime make or equivalent.

13) FRP DELUXE PLAIN SLIDE HT. 2.1 MTR



TECHNICAL SPECIFICATIONS M&E

Ground Space: 5.2 Mtr x 0.61 Mtr

Safe Play Area: 7.4 Mtr x 1.8 Mtr

Structure, ladder & Platform: The centre pipe is of 80 NB B Class GI pipe & Landing pipe is of 25 NB B Class GI Pipe. Ladder frame duly bend is of 25 NB & 20 NB GI B Class pipe. Platform is made of 14 SWG GI sheet with Anti-Skid design for firm foot grip. Triangular Steps are of 16 SWG GI sheet. Slide Chute: Deluxe Slide Chute is made from 6-7 mm thick fibber Reinforced Plastic (FRP) material. Caps, Nut Bolts: All Nut Bolts are G.I / M.S/ Stainless Steel material. Closing Caps are made up of LLDPE / HDPE /M.S. Nylon cap to protect from rain and dust. Powder Coating: The Equipment shall be Powder coated of at least 30-50 microns thickness using AkzoNobel /Berger /Prime make or equivalent.

14) FRP DELUXE WAVE SLIDE HT. 1.5 MTR



Ground Space: 3.8 Mtr x 0.6 Mtr

Safe Play Area: 6.0 Mtr x 1.8 Mtr

Structure, ladder & Platform: The centre pipe is of 80 NB B Class GI pipe. Ladder frame duly bend is of 25 NB & 20 NB GI B Class pipe. Platform is made of 14 SWG GI sheet with Anti-Skid design for firm foot grip. Triangular Steps are of 16 SWG GI sheet. Slide Chute: Deluxe Slide Chute is made from 6-7 mm thick fibber Reinforced Plastic (FRP) material. Caps, Nut Bolts: All Nut Bolts are G.I / M.S/ Stainless Steel material. Closing Caps are made up of LLDPE / HDPE /M.S. Nylon cap to protect from rain and dust. Powder Coating: The Equipment shall be Powder coated of at least 30-50 microns thickness using AkzoNobel /Berger /Prime make or equivalent.

TECHNICAL SPECIFICATIONS M&E

15) FRP DELUXE WAVE SLIDE HT. 2.1 MTR



Ground Space: 5.3 Mtr x 0.61 Mtr

Safe Play Area: 7.5 Mtr x 1.8 Mtr

Structure, ladder & Platform: The centre pipe is of 80 NB B Class GI pipe & Landing pipe is of 25 NB B Class GI Pipe. Ladder frame duly bend is of 25 NB & 20 NB GI B Class pipe. Platform is made of 14 SWG GI sheet with Anti-Skid design for firm foot grip. Triangular Steps are of 16 SWG GI sheet Slide Chute: Deluxe Slide Chute is made from 6-7 mm thick fiber Reinforced Plastic (FRP) material. Caps, Nut Bolts: All Nut Bolts are G.I / M.S/ Stainless Steel material. Closing Caps are made up of LLDPE / HDPE /M.S. Nylon cap to protect from rain and dust. Powder Coating: The Equipment shall be Powder coated of at least 30-50 microns thickness using AkzoNobel /Berger /Prime make or equivalent.

16) PLATFORM MGR FRP TOP



Ground Space: 1.8 Mtr Dia

Safe Play Area: 3.8 Mtr Dia

Structure: The platform of this merry-go-round consists of Non-Skid type FRP Top of 6 mm Thickness. It is provided with handrails of 20 NB B Class GI pipes. Shaft & Bearings: Centre Support 70 mm bright Rod. Main housing Seamless Pipe. Main Bearing Thrust 51312 Bearing & Centre Guide Bearing 6310. The Bearing used in this item is of dual heavy-duty bearing lubricated with water sealant 51312 & 6310. Caps, Nut Bolts: All Nut Bolts are G.I /

TECHNICAL SPECIFICATIONS M&E

M.S/ Stainless Steel material. Closing Caps are made up of LLDPE / HDPE /M.S. Nylon cap to protect from rain and dust. Powder Coating: The Equipment shall be Powder coated of at least 30-50 microns thickness using AkzoNobel /Berger /Prime make or equivalent and PU Paint.

17) FRP MINI WAVE SLIDE HT 0.9 MTR



Ground Space: 2.2 Mtr x 0.61 Mtr

Safe Play Area: 4.4 Mtr x 1.8 Mtr

Structure, ladder & Platform: The centre pipe is of 80 NB B Class GI pipe. Ladder frame duly bend is of 25 NB & 20 NB GI B Class pipe. Platform is made of 14 SWG GI sheet with Anti-Skid design for firm foot grip. Triangular Steps are of 16 SWG GI sheet. Slide Chute: Deluxe Slide Chute is made from 6-7 mm thick fibber Reinforced Plastic (FRP) material. Caps, Nut Bolts: All Nut Bolts are G.I / M.S/ Stainless Steel material. Closing Caps are made up of LLDPE / HDPE /M.S. Nylon cap to protect from rain and dust. Powder Coating: The Equipment shall be Powder coated of at least 30-50 microns thickness using AkzoNobel /Berger /Prime make or equivalent.

18) CIRCULAR SWING



Ground Space: 1.7 Mtr x 1.5 Mtr

Safe Play Area: 2.7 Mtr x 2.7 Mtr

TECHNICAL SPECIFICATIONS M&E

Structure: The main pipe is of 40 NB B Class GI pipe & Top bar is of 50 NB B Class GI Pipe & the frames of swing is made of 25 NB B Class GI Pipe & 15 NB B Class GI Pipe. The main pipe & top bar pipe is attached with junction box which is made of 4mm MS plate with GI plating. Seat: The swing contains two seat which is made of moulded plastic in ROTO /FRP moulding process. The platform for keeping foot is made of aluminium chequered plate and bearing assembly shall be made. Caps, Nut Bolts: All Nut Bolts are G.I / M.S/ Stainless Steel material. Closing Caps are made up of LLDPE / HDPE /M.S. Nylon cap to protect from rain and dust. Powder Coating: The Equipment shall be Powder coated of at least 30-50 microns thickness using AkzoNobel /Berger /Prime make or equivalent.

19) SINGLE SWING ECO



Ground Space: 1.5 Mtr x 2.6 Mtr

Safe Play Area: 2.7 Mtr x 5.0 Mtr

Structure: The main pipe is of 40 NB B Class GI pipe & Top bar is of 50 NB B Class GI Pipe. The main pipe & top bar pipe is attached with junction box which is made of 4mm MS plate with GI plating. Clamps, Chain, Rubber Belt: The swing Seat is made of 10mm thick Anti-Skid chequered reinforced rubber or moulded seat with SS side inserts to fix the SS hooks. Swing Clamps are made from Nylon 6 material with special SS Hook that holds the bearing and is locked with pin & circlip. Chains are Tested link MS chains which are Plated & coated with Plastisol rubber coating to save it from rusting. Caps, Nut Bolts: All Nut Bolts are G.I / M.S/ Stainless Steel material. Closing Caps are made up of LLDPE / HDPE /M.S. Nylon cap to protect from rain and dust. Powder Coating: The Equipment shall be Powder coated of at least 30-50 microns thickness using AkzoNobel /Berger /Prime make or equivalent.

20) FRP ROLLER SLIDE 1.5 MTR



REC. AGE: - 4 – 12 YRS.

THE AREA: - 5.2 M X 4.2 M

SAFE PLAY AREA: - 6.7 M X 5.7 M

HEIGHT: - 1.5 M

Structure, ladder & Platform: The centre pipe is of 80 NB B Class GI pipe & Landing pipe is of 25 NB B Class GI Pipe. Ladder frame duly bend is of 25 NB & 20 NB GI B Class pipe. Platform is made of 14 SWG GI sheet with Anti-Skid design for firm foot grip. Triangular Steps are of 16 SWG GI sheet. Slide Chute: Slide Chute is made from 6-7 mm thick fiber Reinforced Plastic (FRP) material. plastic rollers. The rollers shall be made of High-Density Polyethylene Plastic (HDPE) with UV stabilized. Roller's rod shall be made of 12mm Dia bright rod & also nylon bush is fitted in roller for smooth rotation. Caps, Nut Bolts: All Nut Bolts are G.I / M.S/ Stainless Steel material. Closing Caps are made up of LLDPE / HDPE /M.S. Nylon cap to protect from rain and dust. Powder Coating: The Equipment shall be Powder coated of at least 30-50 microns thickness using AkzoNobel /Berger /Prime make or equivalent.

21) FRP ROLLER SLIDE 2.1 MT



REC. AGE: - 4 – 12 YRS.

THE AREA: - 5.2 M X 4.2 M

SAFE PLAY AREA: - 6.7 M X 5.7 M

TECHNICAL SPECIFICATIONS M&E

HEIGHT: - 2.1 M

Structure, ladder & Platform: The centre pipe is of 80 NB B Class GI pipe & Landing pipe is of 25 NB B Class GI Pipe. Ladder frame duly bend is of 25 NB & 20 NB GI B Class pipe. Platform is made of 14 SWG GI sheet with Anti-Skid design for firm foot grip. Triangular Steps are of 16 SWG GI sheet. Slide Chute: Slide Chute is made from 6-7 mm thick fibber Reinforced Plastic (FRP) material. plastic rollers. The rollers shall be made of High-Density Polyethylene Plastic (HDPE) with UV stabilized. Roller's rod shall be made of 12mm Dia bright rod & also nylon bush is fitted in roller for smooth rotation. Caps, Nut Bolts: All Nut Bolts are G.I / M.S/ Stainless Steel material. Closing Caps are made up of LLDPE / HDPE /M.S. Nylon cap to protect from rain and dust. Powder Coating: The Equipment shall be Powder coated of at least 30-50 microns thickness using AkzoNobel /Berger /Prime make or equivalent.

22) FRP / ROTO SPIRAL SLIDE HT.1.5 MTR



Ground Space: 4.2 Mtr x 2.0 Mtr

Safe Play Area: 6.4 Mtr x 3.2 Mtr

Structure, ladder & Platform: The platform structure pipes are of 80 NB B Class GI pipe. Ladder frame duly bend is of 25 NB B Class GI pipe. Platform is made of FRP 6-7mm thick with Anti-Skid design for firm foot grip. Triangular Steps are of 16 SWG GI sheet. FRP / Roto slide centre support is made of 80 NB B class GI pipe. Roto railing support made from 20 NG B class GI pipe. FRP / Roto Slide Chute- The slide is made by FRP / ROTO with the wall thickness of 3/5mm. LLDPE material used is FOOD GRADE and meets the requirement for standard IS:10146 added with UV stabilizer and antioxidants to protect it from UV rays and oxidization, respectively. Weight of Roto /FRP Slide – The weight of slide chute is 70 Kg. Clamps, Roto railing: Clamps for railing are made of Nylon 6 material. Railing is made from LLDPE material used is FOOD GRADE and meets the requirement for standard IS:10146 added with UV stabilizer and antioxidants to protect it from UV rays and oxidization, respectively. Caps, Nut Bolts: All Nut Bolts are G.I / M.S/ Stainless Steel material. Closing Caps are made up of LLDPE / HDPE /M.S. Nylon cap to protect from rain and dust. Powder Coating: The Equipment shall be Powder coated of at least 30-50 microns thickness using AkzoNobel /Berger /Prime make or equivalent.

TECHNICAL SPECIFICATIONS M&E

23) WIDE SLIDE HT 1.2 MTR (S.S.)



Ground Space: 3.9 Mtr x 0.9 Mtr

Safe Play Area: 6.1 Mtr x 2.1 Mtr

Structure, ladder & Platform: The centre pipe is of 40 NB B Class GI pipe & Landing pipe is of 25 NB B Class GI Pipe. Ladder frame duly bend is of 25 NB & 20 NB GI B Class pipe. Platform is made of 14 SWG GI sheet with Anti-Skid design for firm foot grip. Triangular Steps are of 16 SWG GI sheet. Slide Chute: Slide Chute is supported by 40 x 5 MS angles & the chute is made of SS Sheet. The stainless-steel sheet used is SS 304 Grade. Caps, Nut Bolts: All Nut Bolts are G.I / M.S/ Stainless Steel material. Closing Caps are made up of LLDPE / HDPE /M.S. Nylon cap to protect from rain and dust. Powder Coating: The Equipment shall be Powder coated of at least 30-50 microns thickness using AkzoNobel /Berger /Prime make or equivalent.

24) FRP TRIPPLE WAVE SLIDE HT 1.5 MTR



Ground Space: 5.5 Mtr x 2.5 Mtr

Safe Play Area: 6.5 Mtr x 3.5 Mtr

Structure, ladder & Platform: The platform structure pipes are of 80 NB B Class GI pipe. Ladder frame duly bend is of 25 NB B Class GI pipe. Platform is made of FRP 6-7mm thick with Anti-Skid design for firm foot grip. Triangular Steps are of 16 SWG GI sheet. Roto slide centre support is made of 80 NB B class GI pipe. Roto railing support made from 20 NG B

TECHNICAL SPECIFICATIONS M&E

class GI pipe. Slide Chute- The Slide Chute is made from 6-7 mm thick fibber Reinforced Plastic (FRP) material. Clamps, Roto railing, Caps & Nut Bolts: Clamps for railing are made of Nylon 6 material. Railing is made from LLDPE material used is FOOD GRADE and meets the requirement for standard IS:10146 added with UV stabilizer and antioxidants to protect it from UV rays and oxidization, respectively. All Nut Bolts are Stainless Steel material. Closing Caps are made up of LLDPE / HDPE /M.S. Nylon cap to protect from rain and dust. Caps, Nut Bolts: All Nut Bolts are G.I / M.S/ Stainless Steel material. Closing Caps are made up of LLDPE / HDPE /M.S. Nylon cap to protect from rain and dust. Powder Coating: The Equipment shall be Powder coated of at least 30-50 microns thickness using AkzoNobel /Berger /Prime make or equivalent.

25) FRP TRIPPLE WAVE SLIDE HT 2.1 MTR



Ground Space: 5.6 Mtr x 2.5 Mtr

Safe Play Area: 7.8 Mtr x 3.7 Mtr

Structure, ladder & Platform: The platform structure pipes are of 80 NB B Class GI pipe. Ladder frame duly bend is of 25 NB B Class GI pipe. Platform is made of FRP 6-7 mm thick with Anti-Skid design for firm foot grip. Triangular Steps are of 16 SWG GI sheet. Roto slide centre support is made of 80 NB B class GI pipe. Roto railing support made from 20 NG B class GI pipe. Slide Chute- The Slide Chute is made from 6-7 mm thick fibber Reinforced Plastic (FRP) material. Clamps, Roto railing: Clamps for railing are made of Nylon 6 material. Railing is made from LLDPE material used is FOOD GRADE and meets the requirement for standard IS:10146 added with UV stabilizer and antioxidants to protect it from UV rays and oxidization, respectively. Caps, Nut Bolts: All Nut Bolts are G.I / M.S/ Stainless Steel material. Closing Caps are made up of LLDPE / HDPE /M.S. Nylon cap to protect from rain and dust. Powder Coating: The Equipment shall be Powder coated of at least 30-50 microns thickness using AkzoNobel /Berger /Prime make or equivalent.

26) STANDARD SEE – SAW



Ground Space: 2.1 Mtr x 0.5 Mtr

Safe Play Area: 3.1 Mtr x 1.5 Mtr

Structure: The horizontal support of the see saw shall is made of 40 NB B Class GI pipe and handle is made of 20 NB B Class GI pipe. Stand made from 50 NB B Class GI pipe with lubricating bush system Seat, Bearing & Pin: Seat of See-Saw is made of FRP/ roto moulding process with the wall thickness of 3/5mm. Bearing 6006ZZ used Housing 70 x 50 mm Seamless Pipe. Centre Pin is 32 mm of SAE8620 material. Caps, Nut Bolts: All Nut Bolts are G.I / M.S/ Stainless Steel material. Closing Caps are made up of LLDPE / HDPE /M.S. Nylon cap to protect from rain and dust. Powder Coating: The Equipment shall be Powder coated of at least 30-50 microns thickness using AkzoNobel /Berger /Prime make or equivalent.

27) PUPPY SEE SAW



Ground Space: 1.9 Mtr x 0.8 Mtr

Safe Play Area: 2.9 Mtr x 1.8 Mtr

Structure: The lever support of the Seesaw shall is made of 80 NB and handle is made of 20 NB GI Pipe. Stand made for 50 NB Pipe Angle Frame for Foundation with Lubricating Bush System. Caps, Nut Bolts, Seat, Bearing & Pin: There Shall be M.S Plate of Size 150 x 200 x 6mm Welded on 80 mm Pipe. Puppy Seat of See-Saw is made of roto moulding process with the wall thickness of 3/5mm. Bearing 6006ZZ used Housing 70 x 50 mm Seamless Pipe. Centre Pin is 32 mm of SAE8620 material. Caps, Nut Bolts: All Nut Bolts are G.I / M.S/ Stainless Steel material. Closing Caps are made up of LLDPE / HDPE /M.S. Nylon cap to protect from rain and dust. Powder Coating: The Equipment shall be Powder coated of at least 30-50 microns thickness using AkzoNobel /Berger /Prime make or equivalent.

TECHNICAL SPECIFICATIONS M&E

28) WE SEE SAW



Ground Space: 1.9 Mtr x 0.8 Mtr

Safe Play Area: 2.9 Mtr x 1.8 Mtr

Structure: The horizontal support of the see saw shall be made of 50 NB B Class GI pipe and handle is made of 20 NB B Class GI pipe. Stand made from 50 NB B Class GI pipe with lubricating bush system. Seat, Bearing & Pin: Seat of See-Saw is made of FRP/ roto moulding process with the wall thickness of 3/5mm. Bearing 6006ZZ used Housing 70 x 50 mm Seamless Pipe. Centre Pin is 32 mm of SAE8620 material. Caps, Nut Bolts: All Nut Bolts are G.I / M.S/ Stainless Steel material. Closing Caps are made up of LLDPE / HDPE /M.S. Nylon cap to protect from rain and dust. Powder Coating: The Equipment shall be Powder coated of at least 30-50 microns thickness using AkzoNobel /Berger /Prime make or equivalent.

29) Four-seater MGR



Ground Space: 2.0 Mtr Dia

Safe Play Area: 3.5 Mtr Dia

Structure: The Bucket Seat MGR is Structure made of 40 NB B Class GI Pipe. Mounted stand is made of 80 NB B Class GI Pipe & footrest pipes is made of 20 NB B Class GI Pipe. Structure support fabricated pipe is made of 25 NB B Class GI Pipe. Seat, Base Plate & Bearings: The seats are made of FRP/LLDPE type. LLDPE material used is FOOD GRADE and meets the requirement for standard IS:10146 added with UV stabilizer and antioxidants to protect it from UV rays and oxidization, respectively. Mounted main base plate thickness is 12 mm & housing with seamless pipe Dia of 104 mm & Centre Support Base Plate 16 mm Thick and Centre Rod 50 mm Thick. The Bearing used in this Item is of dual Heavy-Duty Ball Bearing 6209 Taper Bearing 32209 of SKF, Tata & FAG Which is Permanently Lubricated and is With Water Sealant. Caps, Nut Bolts: All Nut Bolts are G.I / M.S/ Stainless Steel

TECHNICAL SPECIFICATIONS M&E

material. Closing Caps are made up of LLDPE / HDPE /M.S. Nylon cap to protect from rain and dust. Powder Coating: The Equipment shall be Powder coated of at least 30-50 microns thickness using AkzoNobel /Berger /Prime make or equivalent.

30) GARDEN SWING



Ground Space: 1.7 Mtr x 2.0 Mtr

Safe Play Area: 5.0 Mtr x 3.2 Mtr

Structure: The main pipe is of 40 NB B Class GI pipe & Top bar is of 50 NB B Class GI Pipe & the seat frames is made of 20 NB B Class GI Pipe. Clamps, Chain, Seat & Roof: The seat of the swing made of FRP/LLPDE with 4-5mm thickness. It is provided with FRP/PVC roof. The swing is fixed on 6mm thick GI chain. The swing is made of 10mm thick Anti-Skid chequered reinforced rubber or moulded seat which is suspended with Plastisol coated short link chain with 6 mm GI chain. Caps, Nut Bolts: All Nut Bolts are G.I / M.S/ Stainless Steel material. Closing Caps are made up of LLDPE / HDPE /M.S. Nylon cap to protect from rain and dust. Powder Coating: The Equipment shall be Powder coated of at least 30-50 microns thickness using AkzoNobel /Berger /Prime make or equivalent.

31) DELUXE SWING



Ground Space: 1.7 Mtr x 2.0 Mtr

Safe Play Area: 5.0 Mtr x 3.2 Mtr

TECHNICAL SPECIFICATIONS M&E

Structure: The main pipe is of 40 NB B Class GI pipe & Top bar is of 50 NB B Class GI Pipe & the seat frames is made of 20 NB B Class GI Pipe. Clamps, Chain, Seat & Roof: The seat of the swing made of FRP/LLPDE with 4-5mm thickness. It is provided with PVC roof. The swing is fixed on 6mm thick GI chain. The swing is made of 10mm thick Anti-Skid chequered reinforced rubber or moulded seat which is suspended with Plastisol coated short link chain with 6 mm GI chain. Caps, Nut Bolts: All Nut Bolts are G.I / M.S/ Stainless Steel material. Closing Caps are made up of LLDPE / HDPE /M.S. Nylon cap to protect from rain and dust. Powder Coating: The Equipment shall be Powder coated of at least 30-50 microns thickness using AkzoNobel /Berger /Prime make or equivalent.

32) GARDEN BENCH WITH ARM



(I) The area: - 1.5x 0.6 m

(ii) Capacity: - 3 adults.

FRP section: - the seating portion and backrest portion shall be made up of 9 nos. FRP trip 2 to 3 mm thick. C section FRP channel strip of thickness up to 3mm and 1500mm long with wooden finish bolted to both the side frame. The Bench strip consist of nylon end caps provided at the two ends of strips for covering the end. 2. **Cast Iron section-** The Frame and arm shall be made up of cast iron in casting process. The weight shall be 42 kg with arm and 37 kg. without arm. 3. **MS support-** MS flat of size 40X5 mm is to be provided at Two nos. width wise and one no. lengthwise cross support at seat and one no. at back rest. 4. This bench shall comfortably accommodate 3 adults on it. The paint given to the bench shall increase the life of the product.

33) GARDEN BENCH WITHOUT ARM



I) The area: - 1.5x 0.6 m

(ii) Capacity: - 3 adults.

FRP section: - the seating portion and backrest portion shall be made up of 9 nos. FRP trip 2 to 3mm thick. C section FRP channel strip of thickness up to 3mm and 1500mm long with wooden finish bolted to both the side frame. The Bench strip consist of nylon end caps provided at the two ends of strips for covering the end. 2. **Cast Iron section-** The Frame and arm shall be made up of cast iron in casting process. The weight shall be 42 kg with arm and 37 kg. without arm. 3. **MS support-** MS flat of size 40X5 mm is to be provided at Two nos. width wise and one no. lengthwise cross support at seat and one no. at back rest. 4. This bench shall comfortably accommodate 3 adults on it. The paint given to the bench shall increase the life of the product

34) UMBRELLA TABLE



THE AREA: - 3 M X 3 M

CAPACITY: - 4 ADULTS.

This bench shall comfortably accommodate 4 adults on it. Its seats shall be made out of 4 mm thick FRP (fibber Reinforced Plastic) / LLDPE (Low linear Density Poly Ethylene). The centre pole shall be of 80 NB GI pipes. The seat frame shall be made out of 25 NB powder coated GI pipes. The back rest shall be made of 3 mm FRP (fibber Reinforced Plastic)

TECHNICAL SPECIFICATIONS M&E

/LLDPE (Low linear Density Poly Ethylene) / roto for strength. The structure comprises of 50 x 5 Ms flat and the platform of 5 mm thickness. The table shall be made out of FRP (fibber Reinforced Plastic) / LLDPE (Low linear Density Poly Ethylene) with 4 mm thick, while the top tilt able umbrella shall be made out of coloured nylon cloth. This table protects from sun as it has an umbrella.

35) A TO B Net SCRAMBLER



REC. AGE: - 3-8 YEARS

THE AREA: - 4.5M X 2.0M

SAFE PLAY AREA: - 5.5M X 3.0M

It shall consist of a frame of alphabet shape 'A' and 'B' which shall be made from 25 mm NB "B" Class G.I. Pipe. It shall have spacers of mm NB "B" Class G.I. pipe of tread 385 mm and riser 200 mm. It also shall consist of a ladder placed between 'A' and 'B' made from 20- and 25-mm NB "B" Class G.I. pipe. The whole item shall be powder coated to avoid rusting of the pipes and for aesthetic look. The net climber shall be made up of nylon rope of 18 mm diameter which shall be attached by specially designed nylon ball clamps. These ropes shall be provided with pipe frame fabricated from 25 mm NB "B" Class G.I. pipe the rope shall be attached to "U" hooks welded to the frame.

36) NET ROCK SCRAMBLER 1.5 MTR



TECHNICAL SPECIFICATIONS M&E

Safe Play Area: 2.8 Mtr x 4.6 Mtr

Structure & Platform: The main frame is made from 40 NB B Class GI Pipe. The rock n net climber is a combination of both rock and net climber. The platform of the rock climber is made up of 4 mm thick FRP (fibber Reinforced Plastic) / LLDPE (Low linear Density Poly Ethylene)). The rocks shall be bolted on same platform, with a gradient of 65 degree from the ground. The main pipe is attached with junction box which is made of 4mm MS plate with GI plating. **Rope, Net & Clamps:** The net climber is made from 18 mm diameter nylon rope attached by specially designed nylon clamps. These ropes shall be attached to the pipe frame fabricated from 40 NB powder coated B class GI pipe with 'U' hooks. **Caps, Nut Bolts:** All Nut Bolts are G.I / M.S/ Stainless Steel material. Closing Caps are made up of LLDPE / HDPE /M.S. Nylon cap to protect from rain and dust. **Powder Coating:** The Equipment shall be Powder coated of at least 30-50 microns thickness using AkzoNobel /Berger /Prime make or equivalent.

37) NET ROCK SCRAMBLER 2.1 MTR



Ground Space: 1.6 Mtr x 2.5 Mtr

Safe Play Area: 2.8 Mtr x 4.9 Mtr

Structure & Platform: The main frame is made from 40 NB B Class GI pipe. The rock n net climber is a combination of both rock and net climber. The platform of the rock climber is made up of 4 mm thick FRP (fibber Reinforced Plastic) / LLDPE (Low linear Density Poly Ethylene)). The rocks shall be bolted on same platform, with a gradient of 65 degree from the ground. **Rope, Net & Clamps:** The net climber is made from 18 mm diameter nylon rope attached by specially designed nylon clamps. These ropes shall be attached to the pipe frame fabricated from 40 NB powder coated B Class GI Pipe with 'U' hooks. **Caps, Nut Bolts:** All Nut Bolts are G.I / M.S/ Stainless Steel material. Closing Caps are made up of LLDPE / HDPE /M.S. Nylon cap to protect from rain and dust. **Powder Coating:** The Equipment shall be Powder coated of at least 30-50 microns thickness using AkzoNobel /Berger /Prime make or equivalent.

38) RAINBOW CLIMBER HT 1.5 MTR

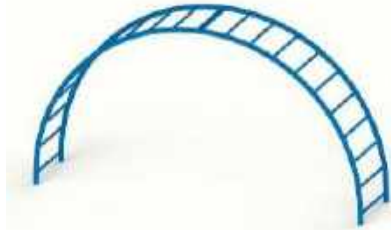

Area: 3.0 mtr x 0.6 mtr

Safe Play Area: 4.0 mtr x 1.2 mtr

Structure: rainbow ladder shall be made up of 40 mm NB 'B' class GI pipe. And the pipes used for steps shall be 20 mm NB 'B' class GI pipe. Caps, Nut Bolts: All Nut Bolts are G.I / M.S/ Stainless Steel material. Closing Caps are made up of LLDPE / HDPE /M.S. Nylon cap to protect from rain and dust. Powder Coating: The Equipment shall be Powder coated of at least 30-50 microns thickness using AkzoNobel /Berger /Prime make or equivalent.

39) RAINBOW CLIMBER HT 2.1 MTR

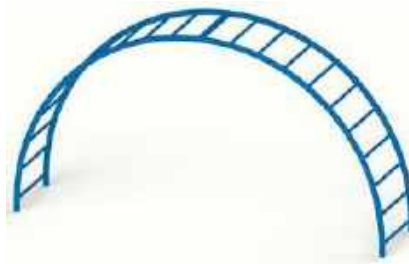

Area: 4.5 mtr x 0.6 Mtr

Safe Play Area: 5.5 mtr x 1.2 mtr

Structure: rainbow ladder shall be made up of 40 mm NB 'B' class GI pipe. And the pipes used for steps shall be 20 mm NB 'B' class GI pipe. Caps, Nut Bolts: All Nut Bolts are G.I / M.S/ Stainless Steel material. Closing Caps are made up of LLDPE / HDPE /M.S. Nylon cap to protect from rain and dust. Powder Coating: The Equipment shall be Powder coated of at least 30-50 microns thickness using AkzoNobel /Berger /Prime make or equivalent.

40) S BRIDGE LADDER SCRAMBLER



Ground Space: 4.5 Mtr x 2.5 Mtr

Safe Play Area: 5.7 Mtr x 4.9 Mtr

Structure: The 'S' bridge ladder is fabricated from 25 NB and 20 NB GI pipes. The vertical supports are made from 40 NB GI pipes with powder coating. Caps, Nut Bolts: All Nut Bolts are G.I / M.S/ Stainless Steel material. Closing Caps are made up of LLDPE / HDPE /M.S. Nylon cap to protect from rain and dust. Powder Coating: The Equipment shall be Powder coated of at least 30-50 microns thickness using AkzoNobel /Berger /Prime make or equivalent.

41) SPIRAL SCRAMBLER 1.5 MTR

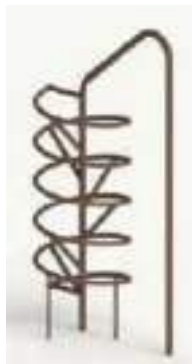

REC. AGE :- 4 - 12 YRS.

THE AREA :- 1.1 M X 0.6 M

SAFE PLAY AREA :- 2.1 M X 1.6 M

HEIGHT :- 1.5 M

The coil shall be fabricated out from 25 mm NB 'B' class GI pipe. The spiral structure shall be suitably bent and shall be kept standing with vertical pipe support of 40 mm NB 'B' class GI pipe. All pipes, flat shall be powder coated to avoid rusting.

42) SPIRAL SCRAMBLER 2.1 MTR



REC. AGE: - 4 - 12 YRS.

THE AREA: - 1.1 M X 0.6 M

SAFE PLAY AREA: - 2.1 M X 1.6 M

HEIGHT: - 2.1 M

The coil shall be fabricated out from 25 mm NB 'B' class GI pipe. The spiral structure shall be suitably bent and shall be kept standing with vertical pipe support of 40 mm NB 'B' class GI pipe. All pipes, flat shall be powder coated to avoid rusting.

43) MINI SUN SET SCRAMBLER



REC. AGE: - 4 - 12 YRS.

THE AREA: - 2.4 M X 2.4 M

SAFE PLAY AREA: - 3.4 M X 3.4 M

HEIGHT: - 1.2 M

Structure: This structure shall be fabricated out of GI pipes of 22 OD. These pipes shall be assembled using 4 mm thick MS plates of 150 mm dia. duly electroplated with powder coating and bent to suit the shape of the product. The whole structure shall be supported on 40 NB B Class GI Pipe. Caps, Nut Bolts: All Nut Bolts are G.I / M.S/ Stainless Steel material. Closing Caps are made up of LLDPE / HDPE /M.S. Nylon cap to protect from rain and dust.

TECHNICAL SPECIFICATIONS M&E

Powder Coating: The Equipment shall be Powder coated of at least 30-50 microns thickness using AkzoNobel /Berger /Prime make or equivalent.

44) DISC BUCKET SWING



Ground Space: 2.5 Mtr x 1.2 Mtr

Safe Play Area: 3.7 Mtr x 5 Mtr

Structure: The main pipe is of 40 NB B Class GI pipe & Top bar is of 50 NB B Class GI Pipe. Clamps, Chain: The swing is fixed on 6mm thick GI chain. The swing is made of 10mm thick Anti-Skid chequered reinforced rubber or moulded seat which is suspended with Plastisol coated short link chain with 6 mm GI chain. Seat is made of rubber with Non-Skid surface with Nylon lining pattern. Caps, Nut Bolts: All Nut Bolts are G.I / M.S/ Stainless Steel material. Closing Caps are made up of LLDPE / HDPE /M.S. Nylon cap to protect from rain and dust. Powder Coating: The Equipment shall be Powder coated of at least 30-50 microns thickness using AkzoNobel /Berger /Prime make or equivalent.

45) SPRING RIDER DUCK



Ground Space: 0.63 Mtr x 0.35 Mtr

Safe Play Area: 1.6 Mtr x 1.0 Mtr

Structure, Handles, & Spring: The handles provided for gripping shall be made up of 16 NB B Class GI Pipes. The duck shall be mounted on a big single spring. Also, a GI flat shall be provided for foot rest. The spring shall be mounted on 5 mm thick plate and the stand for

TECHNICAL SPECIFICATIONS M&E

support shall be made from 40 NB B Class G. I pipe. Duck: Duck shall be made out from FRP/LLDPE (Low linear Density Poly Ethylene) with 3-5 mm thickness made of rotational moulding process. LLDPE material used is FOOD GRADE and meets the requirement for standard IS:10146 added with UV stabilizer and antioxidants to protect it from UV rays and oxidization, respectively. Caps, Nut Bolts: All Nut Bolts are G.I / M.S/ Stainless Steel material. Closing Caps are made up of LLDPE / HDPE /M.S. Nylon cap to protect from rain and dust. Powder Coating: The Equipment shall be Powder coated of at least 30-50 microns thickness using AkzoNobel /Berger /Prime make or equivalent.

46) SPRING RIDER JUMBO



Ground Space: 0.7 Mtr x 0.46 Mtr

Safe Play Area: 1.7 Mtr x 1.46 Mtr

Structure, Handles, & Spring: The handles provided for gripping shall be made up of 16 NB B Class GI Pipes. The duck shall be mounted on a big single spring. Also, a GI flat shall be provided for foot rest. The spring shall be mounted on 5 mm thick plate and the stand for support shall be made from 40 NB B Class G.I pipe. Jumbo: Jumbo shall be made out from FRP (fibber Reinforced Plastic) / LLDPE (Low linear Density Poly Ethylene) with 3-5 mm thickness. Caps, Nut Bolts: All Nut Bolts are G.I / M.S/ Stainless Steel material. Closing Caps are made up of LLDPE / HDPE /M.S. Nylon cap to protect from rain and dust. Powder Coating: The Equipment shall be Powder coated of at least 30-50 microns thickness using AkzoNobel /Berger /Prime make or equivalent.

47) SPRING RIDER PONY



Ground Space: 0.65 Mtr x 0.32 Mtr

Safe Play Area: 1.6 Mtr x 1.0 Mtr

Structure, Handles, & Spring: The handles provided for gripping shall be made up of 16 NB B Class GI Pipes. The duck shall be mounted on a big single spring. Also, a GI flat shall be provided for foot rest. The spring shall be mounted on 5 mm thick plate and the stand for support shall be made from 40 NB B Class G.I pipe. Pony: Pony shall be made out from FRP (fibber Reinforced Plastic) / LLDPE (Low linear Density Poly Ethylene) with 3-5 mm thickness. Caps, Nut Bolts: All Nut Bolts are G.I / M.S/ Stainless Steel material. Closing Caps are made up of LLDPE / HDPE /M.S. Nylon cap to protect from rain and dust. Powder Coating: The Equipment shall be Powder coated of at least 30-50 microns thickness using AkzoNobel /Berger /Prime make or equivalent.

48) WALKING BARREL



Ground Space: 1.5 Mtr x 0.6 Mtr

Safe Play Area: 2.7 Mtr x 3.0 Mtr

Structure: The vertical support shall be made up of 80 NB B Class GI Pipe with handles of 20 NB B Class GI Pipe for holding at the sides. Drum & Bearing: - - The Drum is made by rotational moulding process with the wall thickness of 56mm. LLDPE material used is FOOD GRADE and meets the requirement for standard IS:10146 added with UV stabilizer and

TECHNICAL SPECIFICATIONS M&E

antioxidants to protect it from UV rays and oxidization, respectively. The drum shall revolve with use of Bearing UCP210 with 40NB B Class GI Pipe. Caps, Nut Bolts: All Nut Bolts are G.I / M.S/ Stainless Steel material. Closing Caps are made up of LLDPE / HDPE /M.S. Nylon cap to protect from rain and dust. Powder Coating: The Equipment shall be Powder coated of at least 30-50 microns thickness using AkzoNobel /Berger /Prime make or equivalent.

49) HOPPING PAD (5PCS)



Ground Space: 2.0 Mtr x 0.32 Mtr

Safe Play Area: 4.0 Mtr x 2.5 Mtr

Hopping Pad & Structure: - The hopping pad is made by rotational moulding process with the wall thickness of 4-5mm. LLDPE material used is FOOD GRADE and meets the requirement for standard IS:10146 added with UV stabilizer and antioxidants to protect it from UV rays and oxidization, respectively or shall be made from FRP with 4-5mm thickness. The same shall be fixed to a 5mm thick round welded plate welded to 40 NB B Class GI Pipe of different lengths. Caps, Nut Bolts: All Nut Bolts are G.I / M.S/ Stainless Steel material. Closing Caps are made up of LLDPE / HDPE /M.S. Nylon cap to protect from rain and dust. Powder Coating: The Equipment shall be Powder coated of at least 30-50 microns thickness using AkzoNobel /Berger /Prime make or equivalent.

50) CRYSTAL MAZE



Ground Space: 4.4 Mtr x 4.4 Mtr

Safe Play Area: 6.8 Mtr x 6.8 Mtr

Structure: This globular structure shall be fabricated out of GI pipes of 22 OD. These pipes shall be assembled using 4 mm thick MS plates of 150 mm dia. duly electroplated with

TECHNICAL SPECIFICATIONS M&E

powder coating and bent to suit the shape of the product. The whole structure shall be supported on 40 NB B Class GI Pipe. Caps, Nut Bolts: All Nut Bolts are G.I / M.S/ Stainless Steel material. Closing Caps are made up of LLDPE / HDPE /M.S. Nylon cap to protect from rain and dust. Powder Coating: The Equipment shall be Powder coated of at least 30-50 microns thickness using AkzoNobel /Berger /Prime make or equivalent.

51) CRAWL TUBE

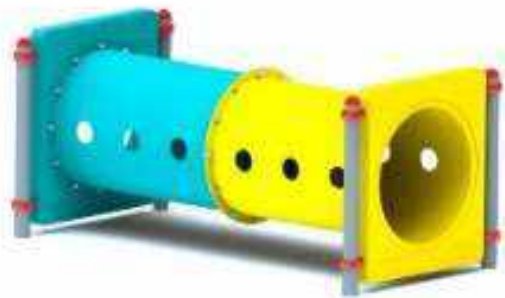

Ground Space: 1.4 Mtr x 1.3 Mtr

Safe Play Area: 3.8 Mtr x 2.52 Mtr

Structure: - The frame of the crawl tube shall be made from 20 NB B Class & 80 NB GI B class pipe. Tunnel, Entry & Clamps: - The Tunnel & its Entry panel made of rotational moulding process with the wall thickness of 3-5mm for the tunnel. LLDPE material used is FOOD GRADE and meets the requirement for standard IS:10146 added with UV stabilizer and antioxidants to protect it from UV rays and oxidization, respectively or FRP material with 6-7 mm thickness. The sides of the tunnel shall be provided with slots for outside view for the children while crawling. The clamps used to fix the tunnel are made from Nylon 6 material. Caps & Nut Bolts: All Nut Bolts are G.I / M.S/ Stainless Steel material. Closing Caps are made up of LLDPE / HDPE /M.S. Nylon cap to protect from rain and dust. Powder Coating: The Equipment shall be Powder coated of at least 30-50 microns thickness using AkzoNobel /Berger /Prime make or equivalent.

52) ARC NET SCRAMBLER WITH SWING SET 4



TECHNICAL SPECIFICATIONS M&E

Ground Space: 3.8 Mtr x 3.8 Mtr

Safe Play Area: 8 Mtr x 8 Mtr

Structure, Rope and Clamps: The arch shaped side frame of are made up of 80 NB GI pipe & horizontal circle is made up of 80 NB GI pipe. 16mm polyester rope galvanized steel wire inside. Height of the frame will be 2.1 Mtr. Rope end fastener is of high strength aluminium and fixed with T connector or Bar clamp made of nylon 6/ metal. Rope cross-over connector made with nylon 6/ metal. Rope end connector made from nylon 6/ metal. Seat, Chain & Hooks: Swing is fitted with special design clamps assembly. Platisol coated short link chain of 6 mm dia. Seat used is rubber with Non-Skid surface with nylon lining pattern. Triangular hook are moulded in belt in such a way that it would not project from the top surface of the belt Seats. Caps & Nut Bolts: All Nut Bolts are G.I/M. S/Stainless Steel material. Closing Caps are made up of LLDPE / HDPE /M.S. Nylon cap to protect from rain and dust. Powder Coating: The Equipment shall be Powder coated of at least 30-50 microns thickness using AkzoNobel /Berger /Prime make or equivalent.

53) We saw



Product Area: 2.00m x 0.50m x 1.05m (6ft x 1.5ft x 3.15ft)

Safe Play Area: 3.0m x 2.00m (9ft x 6ft)

Age Group: 5-12 yrs.

Friends at a time: 2

Technical Specification: postframe all steel are Galvanized conforming to GB/T 13793-2008 with thickness of 2mm.Dimension in 114mmseatLLDPE plastic UT and Bolts: Galvanized/ S.S./Allen Bolt/Button Head Allen Bolt & Nuts / Nylon Lock Nuts are used with PVC Bolt Caps. All open ends of pipe been closed by GI / PVC caps for user safety against entrapment. Certificate: ISO9001:2008,TrueColor: As per Arahant PLAY catalogue Packaging: Safety 3-layer packaging like 1st EPE Foam 2nd HDPE Film and 3rd is Stretch wrap.

54) SKY ROCKER



Ground Space: 2.1 Mtr x 0.3 Mtr

Safe Play Area: 3.3 Mtr x 2.7 Mtr

Structure & Bush: This item shall be made up of 40 NB B Class GI Pipe. The main frame support shall be made from 80 NB B Class GI Pipe. The top pipe shall be inserted into a nylon bush which gives the rider a swinging experience. Caps & Nut Bolts: All Nut Bolts are G.I / M.S/ Stainless Steel material. Closing Caps are made up of LLDPE / HDPE /M.S. Nylon cap to protect from rain and dust. Powder Coating: The Equipment shall be Powder coated of at least 30-50 microns thickness using AkzoNobel /Berger /Prime make or equivalent.

55) TURBO TOWER



Ground Space: 1.8 Mtr x 1.8 Mtr

Safe Play Area: 3.8 Mtr x 3.8 Mtr

Structure & Loop: In this the centre support shall be made up of 80 NB B Class GI Pipes the loop given to the turbo towers shall be made up of 15 NB B Class GI Pipe. The rings of the turbo tower shall be made up of 20 NB B Class GI Pipe. The bend pipes shall be made in 25 NB B Class GI Pipe. There shall be sufficient distance between the rings for the children

TECHNICAL SPECIFICATIONS M&E

climbing on it. Caps& Nut Bolts: All Nut Bolts are G.I / M.S/ Stainless Steel material. Closing Caps are made up of LLDPE / HDPE /M.S. Nylon cap to protect from rain and dust. Powder Coating: The Equipment shall be Powder coated of at least 30-50 microns thickness using AkzoNobel /Berger /Prime make or equivalent.

56) MULTI PURPOSE SCRAMBLER SET 1

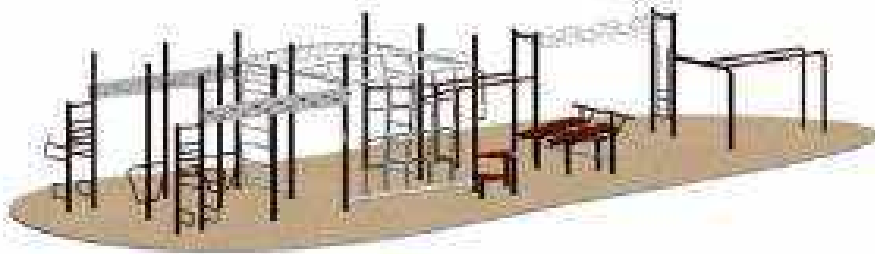

Product Area: 14.650 X 4.150 Mtr

Safe Play Area: 17.650 X 7.150 Mtr

Structure: - The main frame of all scramblers shall be made from 80 NB B Class GI Pipe.

Parallel Bars pipes used shall be of 40 NB B Class GI Pipe.

Serpent Trek is made of using 40 NB & 20 NB B Class GI Pipe. The ladder used shall be designed to the side support pipe itself.

Triangular Steps Platform shall be made of FRP with anti-skid Gel coat finished surface & M. S. Angle frame 40 x 40 x 5. Vertical Support 80mm GI Pipes Entire triangular deck is joined with Nut Bolts.

Loop Scrambler Top pipe is made of using 50 NB B Class G I Pipe. Triangular loops made from 16 NB B Class GI pipe, which shall be welded to the top pipe of the frame.

Vertical Rubber Net Scrambler is made of using 50 NB B Class GI Pipe. Rubber net diameter is 30mm inbuilt 6mm tested chain.

Vertical Arch Shape Scrambler is made of using 20 NB & 32 NB B Class GI Pipe. Top and Bottom pipe is made of using 50 NB B Class G I Pipe.

Cliff hanger Horizontal frame is made of square pipe 50 mm X 50 mm X 3 mm and 3000 mm x 300 mm x 5 mm MS plate with 25 NB GI Pipe for hanger. Cliff hanger MS sheet welded on square pipe frame.

The Horizontal bars Horizontal pipes used shall be of 25 NB B Class GI Pipe.

Pull Up Bar The main frame Pipe is of 80 NB made from B Class G.I. Pipe. The handle frame are of 25 NB B Class GI pipe.

ABS Board The main frame Pipe is of 40 and 25 NB B Class G.I. Pipe. The bottom support is of M.S. round plate of DIA 250 mm & 10mm thick. fibre Reinforced Plastic sheet of 3mm thickness is Bounded on 25 NB B class G.I. pipe of main frame Knee Hip Riser The handle frame is of 25 NB & 32 NB B class GI pipe. The bottom support is of M.S. round plate of DIA 250 mm & 10mm thick. Pull Up Bar The handle frame is of 25 NB & 50 NB B class GI pipe. Caps, Nut Bolts, Bearing & stopper: All Nut Bolts are M.S/S.S. material. Closing Caps are made up of LLDPE / HDPE /M.S. Nylon cap to protect from rain and dust. Powder Coating:

TECHNICAL SPECIFICATIONS M&E

The Equipment shall first be coated with using AkzoNobel /Berger /Prime make or its equivalent primer powder coating of at least 30-40 microns followed by Polyester Powder Coating of at least 30-50 microns thickness using AkzoNobel /Berger /Prime make or equivalent. Powder coating colour is TGTC & Lead free & passes the 1000-hour salt spray test & MEK solvent resistance rub test – ASTM D5402.

57) MULTI PURPOSE SCRAMBLER SET 2

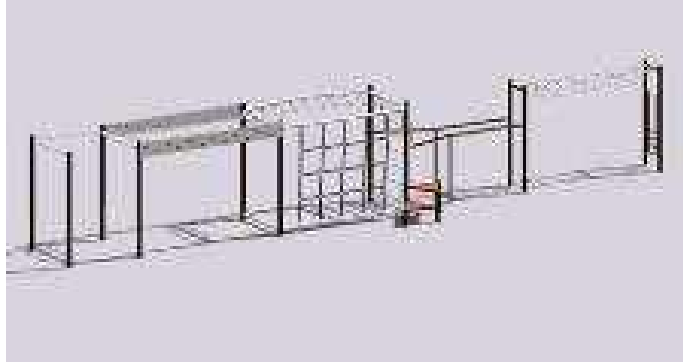

Product Area:13.225 X 2.467 Mtr

Safe Play Area:16.225 X 5.467 Mtr

Structure & Loop: - The main frame of all scramblers shall be made from 80 NB B Class GI Pipe.

Parallel Bars pipes used shall be of 40 NB B Class GI Pipe.

Serpent Trek is made of using 40 NB & 20 NB B Class GI Pipe. The ladder used shall be designed to the side support pipe itself.

Triangular Steps Platform shall be made of FRP with anti-skid Gel coat finished surface & M. S. Angle frame 40 x 40 x 5. Vertical Support 80mm GI Pipes Entire triangular deck is joined with Nut Bolts. Loop Scrambler Top pipe is made of using 50 NB B Class G I Pipe. Triangular loops made from 16 NB B Class GI pipe, which shall be welded to the top pipe of the frame. Vertical Rubber Net Scrambler is made of using 50 NB B Class GI Pipe. Rubber net diameter is 30mm inbuilt 6mm tested chain Vertical Arch Shape Scrambler is made of using 20 NB & 32 NB B Class GI Pipe. Top and Bottom pipe is made of using 50 NB B Class G I Pipe. Cliff hanger Horizontal frame is made of square pipe 50 mm X 50 mm X 3 mm and 3000 mm x 300 mm x 5 mm MS plate with 25 NB GI Pipe for hanger. Cliff hanger MS sheet welded on square pipe frame.

The Horizontal bars Horizontal pipes used shall be of 25 NB B Class GI Pipe Pull Up Bar The main frame Pipe is of 80 NB made from B Class G.I. Pipe. The handle frame is of 25 NB B Class GI pipe Caps, Nut Bolts, Bearing & stopper: All Nut Bolts are M.S/S.S. material. Closing Caps are made up of LLDPE / HDPE /M.S. Nylon cap to protect from rain and dust.

Powder Coating: The Equipment shall first be coated with using AkzoNobel /Berger /Prime make or its equivalent primer powder coating of at least 30-40 microns followed by Polyester Powder Coating of at least 30-50 microns thickness using AkzoNobel /Berger /Prime make or equivalent. Powder coating colour is TGTC & Lead free & passes the 1000-hour salt spray test & MEK solvent resistance rub test – ASTM D5402.

58) MULTI PURPOSE SCRAMBLER SET 3

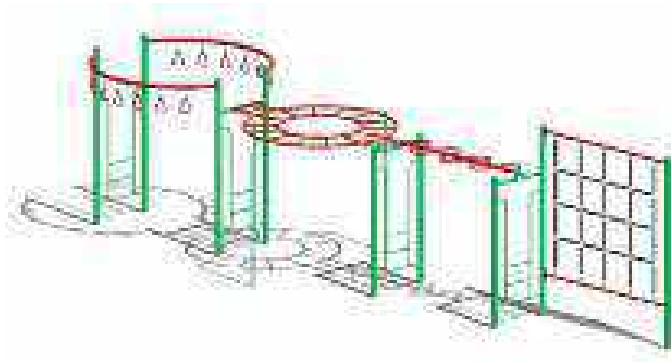

Ground Space: 10.563 Mtr x 2.696 Mtr

Safe Play Area: 13.563 Mtr x 5.696 Mtr

Structure & Loop: The main frame of all scramblers shall be made from 80 NB B Class GI Pipe. Curve loop scrambler, spider scrambler is made of using 50 NB B Class GI Pipe, orbit scrambler is made of using 20 NB & 25 NB B Class GI Pipe & Vertical Rubber Net scrambler is made of using 40 NB B Class GI Pipe.

Rubber net & Clamps: - The clamps shall be made of LLDPE. The climber is made from 18 mm diameter Rubber Net Scrambler is made of using 50 NB B Class GI Pipe. Rubber net diameter is 30mm inbuilt 6mm tested chain.

Caps, Nut Bolts: All Nut Bolts are M.S / Stainless Steel material. Closing Caps are made up of LLDPE /HDPE /M.S. Nylon cap to protect from rain and dust. Powder Coating: The Equipment shall first be coated with using AkzoNobel /Berger /Prime make or its equivalent primer powder coating of at least 30-40 microns followed by Polyester Powder Coating of at least 30-50 microns thickness using AkzoNobel /Berger /Prime make or equivalent. Powder coating colour is TGTC & Lead free & passes the 1000-hour salt spray test & MEK solvent resistance rub test – ASTM D5402.

59) MULTI PURPOSE SCRAMBLER SET 4



Ground Space: 11 Mtr x 2.0 Mtr

Safe Play Area: 14.4 Mtr x 5.7 Mtr

TECHNICAL SPECIFICATIONS M&E

Structure & Loop: - The main frame of all scramblers shall be made from 80 NB B Class GI Pipe. Serpent trek, Twisting Hover Beam & vertical rope net scrambler is made of using 40 NB B Class GI Pipe, ring scrambler is made of using 50 NB B Class GI Pipe, & Cliff hanger main frame is made of using 80 NB B Class GI Pipe & Horizontal frames is made of square pipe which contains 50mm x 50mm x 3mm with MS plate 6mm welded.

Rope & Clamps: The clamps shall be made of LLDPE. The climber is made from 18 mm diameter nylon rope attached by specially designed nylon ball clamps. These ropes shall be attached to the pipe frame fabricated from 40 NB powder coated B Class GI Pipe with 'U' hooks. Caps, Nut Bolts, Bearing & stopper: All Nut Bolts are M.S / Stainless Steel material.

Closing Caps are made up of LLDPE / HDPE /M.S. Nylon cap to protect from rain and dust.

Powder Coating: The Equipment shall first be coated with using AkzoNobel /Berger /Prime make or its equivalent primer powder coating of at least 30-40 microns followed by Polyester Powder Coating of at least 30-50 microns thickness using AkzoNobel /Berger /Prime make or equivalent. Powder coating colour is TGTC & Lead free & passes the 1000-hour salt spray test & MEK solvent resistance rub test – ASTM D5402.

60) RUBBER MATT PER SQ MTR Without PCC

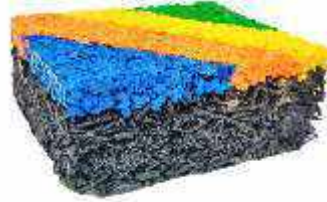

The 3 1/4 "Playground Tiles shall be in solid form or with a "waffle" shaped bottom and in accordance with ASTM F1292-95 qualifies for a fall height of nine (9) feet. This certified tile shall be used where a fall height rating shall be required, for example, beneath playground equipment. The 30 mm bottom SBR & top layer 6 mm EPD solid Playground Tiles have a solid bottom, and shall be used in areas of the playground where cuts shall be required, and or areas that do not call for a fall height rating. Standard colours include black, terracotta, Grey, green and blue.

61) RUBBER MATT PER SQ with PCC



Proving and fixing rubber flooring: 36 mm consist of rubber crumb:

TECHNICAL SPECIFICATIONS M&E

30 mm granules (Rubber Crumbs) 6mm epdm rubber flooring epdm rubber (ethylene propylene diene monomer (m class rubber) having following Technical data: Density 780 g/cm³ Tolerance ±10, Hardness 65 Shore A Tolerance ±5, Tensile Strength >5.5 Map, Elongation at break >580%, Colour Stability 4-5 Grey Scale, EPDM Content 22% Tolerance ±0.5%, Base Polymer is Ethylene Propylene Diene Rubber (EPDM).

62) ARTIFICIAL GRASS 35 MM without PCC - per sq.mtr



4 TONE PE (CROWN SHAPE) + PP CURL 35 MM + 1 MM 3/8
16 STITCHES / 10 CM + 3% 7600 DETEX
DENSITY: 16800 PER SQM
BACKING: PP CLOTH + MESH + SBR LATEX

63) ARTIFICIAL GRASS 35 MM with PCC (100 mm) - Per Sq. Mtr



4 TONE PE (CROWN SHAPE) + PP
CURL 35 MM + 1 MM 3/8
16 STITCHES / 10 CM + 3% 7600 DETEX
DENSITY: 16800 PER SQM
BACKING: PP CLOTH + MESH + SBR LATEX

"Ground surface required under Artificial Grass

1. Excavation for foundation in earth, soil of all types, sand, gravel and soft murum up to 0.50-meter depth including elsewhere,) preparing the bed for the foundation and necessary backfilling, ramming, watering complete excluding shoring and strutting.
2. Providing dry trap/ rubber stone soling 15 cm to 20 cm thick including hand packing and compacting etc. Complete.

Rs. /- Per Sq. Mtr.

TECHNICAL SPECIFICATIONS M&E

3. Proving and laying in situ plain cement concrete 1:1 1/2: 3 (m- 20) of trap metal for foundation and bedding including bailing out water manually, form work, compacting and curing.
4. proving second class burnt brick masonry with conventional / is. Type brick in cement mortar 1: 6 in foundation and plinth of inner walls/ in plinth of external walls including bailing out water manually, striking joints on unexposed faces racking out joints on exposed faces and watering completing.
5. proving external cement plaster 20mm thick in one coat in cement mortar 1: 4 to concrete or brick surface or stone surface in all positions and curing complete.

64) SQUARE DECK HT. 0.9 MTR. (MAPS)

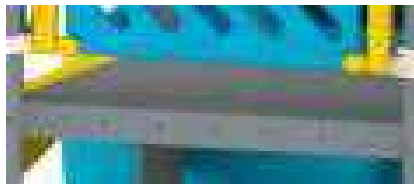

The platform shall be made up of FRP (fiber Reinforced Plastic) / LLDPE (Low linear Density Poly Ethylene) 5 to 6 mm thickness with anti-skid surface. Platform of each side should be equal in length 1.16m x 1.16m. The platform support shall be with 80 mm NB GI 'B' Class pipe. Braising square frame shall be made from 40 x 40 x 5 mm thickness MS angle. Top Canopy shall be made of FRP (fiber Reinforced Plastic) / LLDPE (Low linear Density Poly Ethylene) with thickness of 2-3 mm. Canopy 's clamp shall be specially designed 80 mm NB in nylon. Total area required for square deck 0.9 x 0.9 Mtr. All pipes, frames, and flats shall be powder coated to avoid rusting.

65) SQUARE DECK HT. 1.5 MTR. (MAPS)

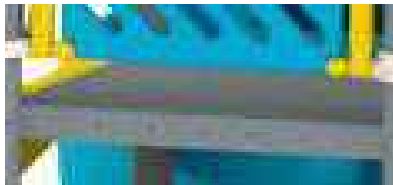

The platform shall be made up of FRP (fiber Reinforced Plastic) / LLDPE (Low linear Density Poly Ethylene) 5 to 6 mm thickness with anti-skid surface. Platform of each side should be equal in length 1.16m x 1.16m. The platform support shall be with 80 mm NB GI 'B' Class pipe. Braising square frame shall be made from 40 x 40 x 5 mm thickness MS angle. Top Canopy shall be made of FRP (fiber Reinforced Plastic) / LLDPE (Low linear Density Poly Ethylene) with thickness of 2-3 mm. Canopy 's clamp shall be specially designed 80 mm NB in nylon. Total area required for square deck 1.5 x 1.5 Mtr. All pipes, frames, and flats shall be powder coated to avoid rusting.

TECHNICAL SPECIFICATIONS M&E

66) SQUARE DECK HT. 2.1 MTR. (MAPS)



The platform shall be made up of FRP (fiber Reinforced Plastic) / LLDPE (Low linear Density Poly Ethylene) 5 to 6 mm thickness with anti-skid surface. Platform of each side should be equal in length 1.16m x 1.16m. The platform support shall be with 80 mm NB GI 'B' Class pipe. Braising square frame shall be made from 40 x 40 x 5 mm thickness MS angle. Top Canopy shall be made of FRP (fiber Reinforced Plastic) / LLDPE (Low linear Density Poly Ethylene) with thickness of 2-3 mm. Canopy 's clamp shall be specially designed 80 mm NB in nylon. Total area required for square deck 2.1 x 2.1 Mtr. All pipes, frames, and flats shall be powder coated to avoid rusting.

67) SQUARE DECK HT. 2.7 MTR. (MAPS)



The platform shall be made up of FRP (fiber Reinforced Plastic) / LLDPE (Low linear Density Poly Ethylene) 5 to 6 mm thickness with anti-skid surface. Platform of each side should be equal in length 1.16m x 1.16m. The platform support shall be with 80 mm NB GI 'B' Class pipe. Braising square frame shall be made from 40 x 40 x 5 mm thickness MS angle. Top Canopy shall be made of FRP (fiber Reinforced Plastic) / LLDPE (Low linear Density Poly Ethylene) with thickness of 2-3 mm. Canopy 's clamp shall be specially designed 80 mm NB in nylon. Total area required for square deck 2.7 x 2.7 Mtr. All pipes, frames, and flats shall be powder coated to avoid rusting.

68) HEX DECK HT. 0.9 MTR. (MAPS)

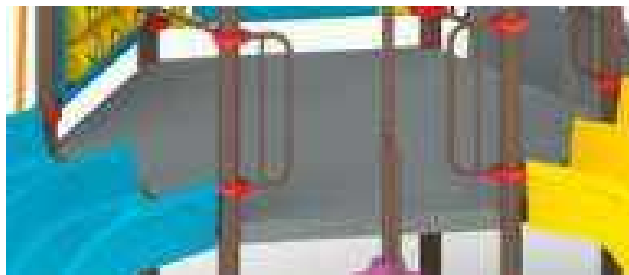

TECHNICAL SPECIFICATIONS M&E

The platform shall be made up of FRP (fiber Reinforced Plastic) / LLDPE (Low linear Density Poly Ethylene) 5 to 6 mm thickness with anti-skid surface. Platform of each side should be equal in length 1.16m x 1.16m. The platform support with 80 mm NB GI 'B' Class pipe. Braising hexagonal frame shall be made from 40 x 40 x 5 mm thickness MS angle. Top Canopy shall be made of FRP (fiber Reinforced Plastic) / LLDPE (Low linear Density Poly Ethylene) with thickness of 2-3 mm. Canopy 's clamp shall be specially design 80 mm NB in nylon. Total area required for square deck 2.7 x 2.7 Mtr. Platform support pipe and Braising frame shall be powder coated to avoid rusting.

69) HEX DECK HT. 1.5 MTR. (MAPS)

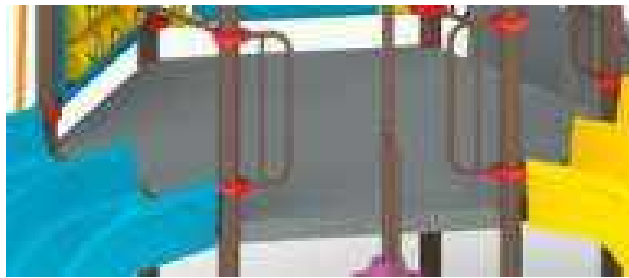

The platform shall be made up of FRP (fiber Reinforced Plastic) / LLDPE (Low linear Density Poly Ethylene) 5 to 6 mm thickness with anti-skid surface. Platform of each side should be equal in length 1.16m x 1.16m. The platform support with 80 mm NB GI 'B' Class pipe. Braising hexagonal frame shall be made from 40 x 40 x 5 mm thickness MS angle. Top Canopy shall be made of FRP (fiber Reinforced Plastic) / LLDPE (Low linear Density Poly Ethylene) with thickness of 2-3 mm. Canopy 's clamp shall be specially design 80 mm NB in nylon. Total area required for square deck 2.7 x 2.7 Mtr. Platform support pipe and Braising frame shall be powder coated to avoid rusting.

70) HEX DECK HT. 2.1 MTR. (MAPS)

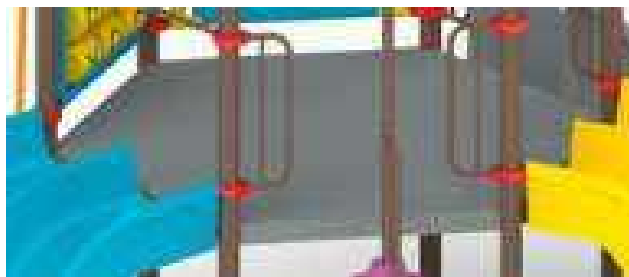

The platform shall be made up of FRP (fiber Reinforced Plastic) / LLDPE (Low linear Density Poly Ethylene) 5 to 6 mm thickness with anti-skid surface. Platform of each side should be equal in length 1.16m x 1.16m. The platform support with 80 mm NB GI 'B' Class pipe. Braising hexagonal frame shall be made from 40 x 40 x 5 mm thickness MS angle. Top

TECHNICAL SPECIFICATIONS M&E

Canopy shall be made of FRP (fiber Reinforced Plastic) / LLDPE (Low linear Density Poly Ethylene) with thickness of 2-3 mm. Canopy 's clamp shall be specially design 80 mm NB in nylon. Total area required for square deck 2.7 x 2.7 Mtr. Platform support pipe and Braising frame shall be powder coated to avoid rusting.

71) HEX DECK HT. 2.7 MTR. (MAPS)

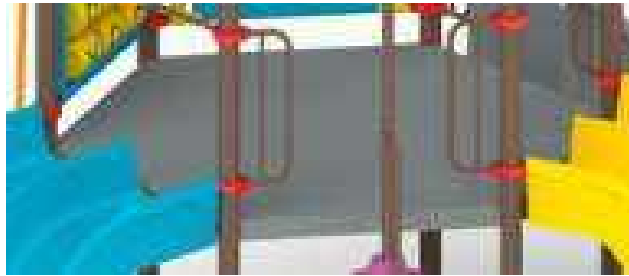

The platform shall be made up of FRP (fiber Reinforced Plastic) / LLDPE (Low linear Density Poly Ethylene) 5 to 6 mm thickness with anti-skid surface. Platform of each side should be equal in length 1.16m x 1.16m. The platform support with 80 mm NB GI 'B' Class pipe. Braising hexagonal frame shall be made from 40 x 40 x 5 mm thickness MS angle. Top Canopy shall be made of FRP (fiber Reinforced Plastic) / LLDPE (Low linear Density Poly Ethylene) with thickness of 2-3 mm. Canopy 's clamp shall be specially design 80 mm NB in nylon. Total area required for square deck 2.7 x 2.7 Mtr. Platform support pipe and Braising frame shall be powder coated to avoid rusting.

72) OCTAGONAL DECK HT. 0.9 MTR. (MAPS)



The platform shall be made up of FRP (fiber Reinforced Plastic) / LLDPE (Low linear Density Poly Ethylene) 5 to 6 mm thickness with anti-skid surface. Platform of each side should be equal in length 1.16m x 1.16m. The platform support with 80 mm NB GI „B“ Class pipe. Braising hexagonal frame shall be made from 40 x 40 x 5 mm thickness MS angle. Top Canopy shall be made of FRP (fiber Reinforced Plastic) / LLDPE (Low linear Density Poly Ethylene) with thickness of 2-3 mm. Canopy's clamp shall be specially design 80 mm NB in nylon. Total area required for square deck 0.9 x 0.9 Mtr. Platform support pipe and Braising frame shall be powder coated to avoid rusting.

73) OCTAGONAL DECK HT. 2.7 MTR. (MAPS)



The platform shall be made up of FRP (fiber Reinforced Plastic) / LLDPE (Low linear Density Poly Ethylene) 5 to 6 mm thickness with anti-skid surface. Platform of each side should be equal in length 1.16m x 1.16m. The platform support with 80 mm NB GI „B“ Class pipe. Braising hexagonal frame shall be made from 40 x 40 x 5 mm thickness MS angle. Top Canopy shall be made of FRP (fiber Reinforced Plastic) / LLDPE (Low linear Density Poly Ethylene) with thickness of 2-3 mm. Canopy's clamp shall be specially design 80 mm NB in nylon. Total area required for square deck 2.7 x 2.7 Mtr. Platform support pipe and Braising frame shall be powder coated to avoid rusting.

74) STAIRCASE 0.9 MTR. HT (WITH RAILING) (MAPS)



The staircase shall be made up of FRP (fiber Reinforced Plastic) / LLDPE (Low linear Density Poly Ethylene) with a conservative thickness of 4 mm. Step should have reinforcement to maintain strength and avoid bending. The top surface of the step should be such that it should not deserve any kind of skiddy movement. Railing shall be made up of 20 mm NB and 25 mm NB „B“ class GI pipe. All railing pipe shall be powder coated to avoid rusting.

75) FRP PLAIN BRIDGE 2.4 MTR LENGTH (MAPS)

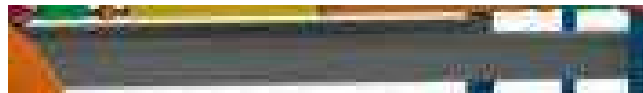

The Platform of plain bridge shall be made of FRP (fiber Reinforced Plastic) / LLDPE (Low linear Density Poly Ethylene) of 4 mm thick with railing attached to it. The railing shall be made from FRP (fiber Reinforced Plastic) / LLDPE (Low linear Density Poly Ethylene) and

TECHNICAL SPECIFICATIONS M&E

shall be supported by 20 mm NB „B” class GI pipe and clamped with 80 mm NB and 80 (mm) x 20(mm) nylon clamp. All pipes shall be powder coated to avoid rusting.

76) TUNNEL 2.4 MTR LENGTH (MAPS)

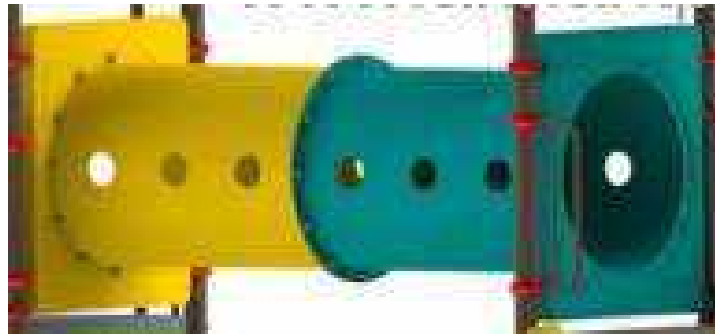

Tunnel landing module shall be made of FRP (fiber Reinforced Plastic) / LLDPE (Low linear Density Poly Ethylene) of 4 mm thickness and top cover shall be made transparent FRP (fiber Reinforced Plastic) / LLDPE (Low linear Density Poly Ethylene) of 3 mm thickness.

77) SWINGING BRIDGE WITH RAILING (2.4M) LENGTH (MAPS)



The swinging bridge frame shall be made of 80 mm NB „B” class GI pipe and 50 x 10 MS flat. And 25 mm thickness wooden (Sal wood) planks attached together with the help of nuts bolts and shall be suspended with 7 mm GI chains. The railing shall be made from FRP (fiber Reinforced Plastic) / LLDPE (Low linear Density Poly Ethylene) and shall be supported by 20 mm NB „B” class GI pipe and clamped with 80 MM NB and 80 (mm) x 20(mm) nylon clamp.

All pipes, MS flat shall be powder coated to avoid rusting.

78) CURVE BRIDGE WITH RAILING (2.4 M): (MAPS)



The bridge shall be made from FRP (fiber Reinforced Plastic) / LLDPE (Low linear Density Poly Ethylene) with 4 mm thick. The railing provided shall be made from FRP (fiber Reinforced Plastic) / LLDPE (Low linear Density Poly Ethylene) and supported by 20 mm NB

TECHNICAL SPECIFICATIONS M&E

'B' class GI pipe and clamped with 80 mm NB and 80 (mm) x 20(mm) nylon clamp. All pipes shall be powder coated to avoid rusting.

79) BOWL SLIDE (MAPS).

The bowl slide shall be made of FRP (fibber Reinforced Plastic) / LLDPE (Low linear Density Poly Ethylene) of 4 mm thick. The bowl shape should be in such a manner that it will not give any jerk or bump to the rider. The chute has its end such as it causes safe landing of the child. The landing portion should be in horizontal with respect to the ground. „H" support shall be made from 25 mm NB „B" class GI pipe and 25 x 10 MS flat. All pipes shall be powder coated to avoid rusting.

80) CROSS-N-ZERO (MAPS)

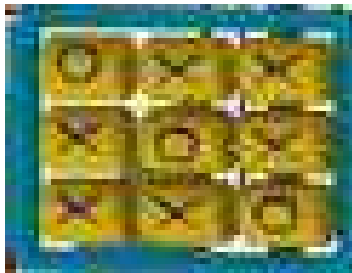

This item provides Brain washing experience to the children and enhances their tactical strength by providing them a intelligent game. The prisms for the "X" and "O" and frame of this item shall be made of FRP (fibber Reinforced Plastic) / LLDPE (Low linear Density Poly Ethylene). Attached "X" and "O" character on prisms shall be made from 3 mm thickness ABS sheet. "X" and "O" drum's pipe shall be made in 15 NB (mm) GI „B" Class pipe and Clamping with 20 NB (mm) GI" B" class pipe. Attached railing with 80 mm NB and 80 (mm) x 20 (mm) nylon clamp. All pipes shall be powder coated to avoid rusting.

81) DOUBLE SWING WITH BELT ASSEMBLY :(MAPS)



The leg support of this item shall be made up of 40 mm NB GI" B" class pipe while the top bar shall be of 50 mm NB GI" B" class pipe. Leg pipe and top bar shall be attached with junction box which shall be made of 4 mm MS plate with GI plating. The two swings shall be

TECHNICAL SPECIFICATIONS M&E

made from 10 mm thick anti-skid chequered reinforced rubber or molded seat, which shall be suspended with rubber coated 6 dia. GI chain. The ball bearings shall be mounted inside a specially designed nylon clamp. The GI pipes shall be powder coated to avoid rusting

82) SINGLE SWING WITH BELT ASSEMBLY: (MAPS)



The leg support of this item shall be made up of 40 mm NB GI" B" class pipe while the top bar shall be of 50 mm NB GI" B" class pipe. Leg pipe and top bar shall be attached with junction box which shall be made of 4 mm MS plate with GI plating. The two swings shall be made from 10 mm thick anti-skid chequered reinforced rubber or molded seat, which shall be suspended with rubber coated 6 dia. GI chain. The ball bearings shall be mounted inside a specially designed nylon clamp. The GI pipes shall be powder coated to avoid rusting

83) WAVE SLIDE 1.5 MTR HT. (MAPS)



The wave slide shall be made of FRP (fiber Reinforced Plastic) / LLDPE (Low linear Density Poly Ethylene) of 4 mm thick. The Wave shape should be in such a manner that it will not give any jerk or bump to the rider. The chute has its end such as it causes safe landing of the child. The landing portion should be in horizontal with respect to the ground. There should be Sliding „H" support shall be made from 25 mm NB „B" class GI pipe and 25 x 10 MS flat. All pipes shall be powder coated to avoid rusting.

84) WAVE SLIDE 2.1 MTR HT. (MAPS)



The wave slide shall be made of FRP (fibre Reinforced Plastic) / LLDPE (Low linear Density Poly Ethylene) of 4 mm thick. The Wave shape should be in such a manner that it will not give any jerk or bump to the rider. The chute has its end such as it causes safe landing of the child. The landing portion should be in horizontal with respect to the ground. There should be Sliding „H“ support shall be made from 25 mm NB „B“ class GI pipe and 25 x 10 MS flat. All pipes shall be powder coated to avoid rusting.

85) SPIRAL SLIDE 1.5 MTR HT. (MAPS)



Spiral slide shall be chute made of FRP (fibre Reinforced Plastic) / LLDPE (Low linear Density Poly Ethylene) having thickness of 4mm. Slide Centre support shall be 80 mm NB „B“ class GI pipe Landing module shall be supported by 20 mm NB „B“ class GI pipe. Slide extension platform shall be made from FRP (fibre Reinforced Plastic) / LLDPE (Low linear Density Poly Ethylene). The railing shall be made from 15- and 20-mm NB „B“ class GI pipe. All pipes shall be powder coated to avoid rusting.

86) SPIRAL SLIDE 2.1 MTR HT. (MAPS)



Spiral slide shall be chute made of FRP (fibre Reinforced Plastic) / LLDPE (Low linear Density Poly Ethylene) having thickness of 4mm. Slide Centre support shall be 80 mm NB „B” class GI pipe Landing module shall be supported by 20 mm NB „B” class GI pipe. Slide extension platform shall be made from FRP (fibre Reinforced Plastic) / LLDPE (Low linear Density Poly Ethylene). The railing shall be made from 15- and 20-mm NB „B” class GI pipe. All pipes shall be powder coated to avoid rusting.

87) SPIRAL SLIDE 2.7 MTR HT. (MAPS)



Spiral slide shall be chute made of FRP (Fibber Reinforced Plastic) / LLDPE (Low linear Density Poly Ethylene) having thickness of 4mm. Slide Center support shall be 80 mm NB „B” class GI pipe Landing module shall be supported by 20 mm NB „B” class GI pipe. extension platform shall be made from FRP (Fiber Reinforced Plastic) / LLDPE (Low linear Density Poly Ethylene). The railing shall be made from 15- and 20-mm NB „B” class GI pipe. All pipes shall be powder coated to avoid rusting.

88) CURVE SLIDE 1.5 MTR HT. (MAPS)



Curve slide shall be made of FRP (Fiber Reinforced Plastic) / LLDPE (Low linear Density Poly Ethylene) having thickness of 4mm. „H” support shall be made from 25 mm NB „B” class GI pipe and 25 x 10 MS flat. All pipes and flat shall be powder coated to avoid rusting.

89) MINI TUBE SLIDE 1.5 MTR. (MAPS)



Tube slide shall be made up 4 mm thick FRP (Fiber Reinforced Plastic) / LLDPE (Low linear Density Poly Ethylene) having smooth finishing. Cross section slide shall be 750 mm Diameter. It shall have a transparent cover so that light can pass through it. Slide shall be supported with „T” support made up 80 mm NB „B” class GI pipe. Specially designed MS Flange of 10 mm thick shall be used for fixing „T” support with slide. All pipes and Flange shall be powder coated to avoid rusting.

90) ROLLER SLIDE 1.5 MTR. HT. (MAPS)



The chute of this slide consists of plastic rollers. The rollers shall be made up of High-Density Polyethylene Plastic (HDPE) with UV stabilized. Roller's rod shall be made from 12 mm die bright rod and nylon bush fitted in Rollers for smooth rotation. The main frame shall be made up of M.S angle 50 x 50 x 5. and MS flat 50 X 3. The handrail shall be made in 25 mm NB GI „B” class pipe. The triangular steps provided shall be made out of 16 SWG GI sheet for firm grip and safety. 'H" support shall be made from 25 mm NB „B” class GI pipe and 25 x 10 MS flat. All pipes, angle and flat shall be powder coated.

91) ROLLER SLIDE 2.1 MTR. HT (MAPS)



The chute of this slide consists of plastic rollers. The rollers shall be made up of High-Density Polyethylene Plastic (HDPE) with UV stabilized. Roller's rod shall be made from 12 mm die bright rod and nylon bush fitted in Rollers for smooth rotation. The main frame shall be made up of M.S angle 50 x 50 x 5. and MS flat 50 X 3. The handrail shall be made in 25 mm NB GI „B” class pipe. The triangular steps provided shall be made out of 16 SWG GI sheet for firm grip and safety. 'H" support shall be made from 25 mm NB „B” class GI pipe and 25 x 10 MS flat. All pipes, angle and flat shall be powder coated.

92) MINI WAVE SLIDE 0.9 Mtr (MAPS)



- (i) REC. AGE: - 3 - 8 YRS.
- (ii) THE AREA: - 2.2 M X 0.6 M
- (iii) SAFE PLAY AREA: - 3.7 M X 2.1M
- (iv) HEIGHT: - 0.9M

In this product the canter support shall be made up of 50 mm NB pipe. The slide portion shall be made in Fiberglass reinforced plastic. The thickness of the mini slide shall be 4mm with proper reinforcement to support the module. The triangular steps of the slide shall be of SWG and ladder frame shall be made in 20 mm NB powder coated "B" Class G.I. pipe. The landing support shall be made up of 25 mm NB "B" Class G.I. Pipe. The ladder shall be designed in such a way there won't be entrapment of child's foot while playing. All the sharp edges and corners properly grinded to give smooth finish so that children shall not hurt while playing the pure polyester powder coating done on the pipes extends the life of equipment's.

93) DOUBLE ROLLER SLIDE (MAPS) 1.5 Mtr



- (i) REC. AGE: - 4 – 12 YRS.
- (ii) THE AREA: - 5.2 M X 4.2 M
- (iii) SAFE PLAY AREA: - 6.7 M X 5.7 M
- (iv) HEIGHT: - 1.5 M

TECHNICAL SPECIFICATIONS M&E

The main frame shall be made up of FRP (Fiber Reinforced Plastic) / LLDPE (Low linear Density Poly Ethylene) 3 mm thickness. Rollers shall be made up of HDPE with UV stabilized pigment. The trapezium platform of the slide shall be made up of the fibreglass reinforced plastic of 5 mm thickness. The vertical platform support pipes used shall be of 80 mm NB powder coated "B" Class G.I. Pipe. The railing shall be made in rotational moulding. The slide entry shall be made up of 20 mm NB powder coated "B" Class G.I. Pipe. The slide entry shall be mounted on 80 mm NB and 80 x 20 mm NB nylon clamp. The ladder frame shall be made in 20 mm NB and 25 mm NB powder coated "B" Class G.I. Pipe. The triangular steps shall be made in 16 SWG G.I. sheets.

94) DOUBLE ROLLER SLIDE 2.1 M (MAPS)



- (i) REC. AGE: - 4 – 12 YRS.
- (ii) THE AREA: - 5.2 M X 4.2 M
- (iii) SAFE PLAY AREA: - 6.7 M X 5.7 M
- (iv) HEIGHT: - 2.1 M

The main frame shall be made up of FRP (Fiber Reinforced Plastic) / LLDPE (Low linear Density Poly Ethylene) 3 mm thickness. Rollers shall be made up of HDPE with UV stabilized pigment. The trapezium platform of the slide shall be made up of the fibreglass reinforced plastic of 5 mm thickness. The vertical platform support pipes used shall be of 80 mm NB powder coated "B" Class G.I. Pipe. The railing shall be made FRP (Fiber Reinforced Plastic) / LLDPE (Low linear Density Poly Ethylene). The slide entry shall be made up of 20 mm NB powder coated "B" Class G.I. Pipe. The slide entry shall be mounted on 80 mm NB and 80 x 20 mm NB nylon clamp. The ladder frame shall be made in 20 mm NB and 25 mm NB powder coated "B" Class G.I. Pipe. The triangular steps shall be made in 16 SWG G.I. sheets.

95) SINGLE ROLLER SLIDE (MAPS) 1.5 Mtr



- (i) REC. AGE: - 4 – 12 YRS.
- (ii) THE AREA: - 5.2 M X 1 M
- (iii) SAFE PLAY AREA: - 6.2 M X 2.0 M
- (iv) HEIGHT: - 1.5 M

The exciting roller slide shall be made up of FRP (Fiber Reinforced Plastic) / LLDPE (Low linear Density Poly Ethylene). The most attractive and enjoyable of its kind, the chute shall consist of moulded plastic rollers spreader over the length. Rollers shall be made up of HDPE with UV stabilized pigment. The square platform of the slide shall be made up of the Fiberglass reinforced plastic. The vertical platform support pipes used shall be of 80 NB powder coated GI pipes. The railing shall be made in FRP (Fiber Reinforced Plastic) / LLDPE (Low linear Density Poly Ethylene). The ladder frame shall be made in 20- and 25-mm NB "B" Class G.I. Pipe. The triangular steps shall be made in 16 SWG GI sheet.

96) SINGLE ROLLER SLIDE 2.1 M (MAPS)



- (i) REC. AGE: - 4 – 12 YRS.
- (ii) THE AREA: - 5.2 M X 1 M
- (iii) SAFE PLAY AREA: - 6.2 M X 2.0 M
- (iv) HEIGHT: - 2.1 M

TECHNICAL SPECIFICATIONS M&E

The exciting roller slide shall be made up of FRP (Fiber Reinforced Plastic) / LLDPE (Low linear Density Poly Ethylene). The most attractive and enjoyable of its kind, the chute of this slide consists of moulded plastic rollers spreader over the length. Rollers shall be made up of HDPE with UV stabilized pigment or FRP (Fiber Reinforced Plastic) / LLDPE (Low linear Density Poly Ethylene). The square platform of the slide shall be made up of the Fiberglass reinforced plastic. The vertical platform support pipes used shall be of 80 NB powder coated GI pipes. The railing shall be made in FRP (Fiber Reinforced Plastic) / LLDPE (Low linear Density Poly Ethylene). The ladder frame shall be made in 20- and 25-mm NB "B" Class G.I. Pipe. The triangular steps shall be made in 16 SWG GI sheets.

97) STRAIGHT CURVE SLIDE (MAPS)

- (i) REC. AGE: - 3-12 Yrs.
- (ii) THE AREA: - 4.7M X 0.8M
- (iii) SAFE PLAY AREA: - 5.7 M X 1.8 M
- (iv) HEIGHT: - 2.1M

In this interesting product the full slide shall be made in FRP (Fiber Reinforced Plastic) / LLDPE (Low linear Density Poly Ethylene). The edges of the slide shall be made in a smooth finish giving it a mirror image and also ensures safety so that the child does not hurt itself while sliding. The steps shall be also made in FRP (Fiber Reinforced Plastic) / LLDPE (Low linear Density Poly Ethylene) in such a way that it won't entrap the foot of the child while climbing and also giving it a smooth finish. This product gives the child full enjoyment while playing and also it is a good exercise for children.

98) DOUBLE ARC SWING (MAPS)



As the name suggests two children can enjoy the swing at one time. The arched shaped side frame shall be made of 80 mm NB „B” class GI pipe and top pipe shall be made up of 50 mm NB „B” class GI pipe. The frame shall be powder coated to give an aesthetic look. The swings shall be made up of 10 mm thick anti-skid rubber top the rubber belt seat shall be suspended on 6 mm rubber coated GI chain. The ball bearings shall be mounted inside a specially designed nylon clamp.

99) SPIRAL CLIMBER 1.5 MTR (MAPS)

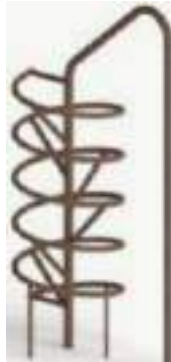

- (i) REC. AGE: - 4 - 12 YRS.
- (ii) THE AREA: - 1.1 M X 0.6 M
- (iii) SAFE PLAY AREA: - 2.1 M X 1.6 M
- (iv) HEIGHT: - 1.5 M

The completely new and attractive item of its kind, provides children an exercising device. The coil shall be fabricated from 25 mm NB „B“ class powder coated GI pipe. The spiral structure shall be suitably bent and shall be kept standing with vertical support of 40 mm NB „B“ class powder coated GI pipe.

100) SPIRAL CLIMBER 2.1 MTR (MAPS)



- (i) REC. AGE - 4 - 12 YRS.
- (ii) THE AREA: - 1.1 M X 0.6 M
- (iii) SAFE PLAY AREA: - 2.1 M X 1.6 M
- (iv) HEIGHT: - 2.1 M

Same as per Item no. 223

101) ROCK CLIMBER 1.5 MTR. HT (MAPS)



Rock climber platform shall be made up of 4 mm thick FRP (Fiber Reinforced Plastic) / LLDPE (Low linear Density Poly Ethylene). Rocks shall be bolted on same platform and ground support for the platform 25 mm NB „B” class GI pipe 50 x 10 MS flat shall be used. All pipes, flat shall be powder coated to avoid rusting.

102) ROCK CLIMBER 2.1 MTR. HT (MAPS)



Rock climber platform shall be made up of 4 mm thick FRP (Fiber Reinforced Plastic) / LDPE (Low linear Density Poly Ethylene). Rocks shall be bolted on same platform and ground support for the platform 25 mm NB „B” class GI pipe 50 x 10 MS flat shall be used. All pipes, flat shall be powder coated to avoid rusting.

103) FRP LADDER 1.5 MTR. HT (MAPS)



The ladder shall be made from FRP (Fiber Reinforced Plastic) / LLDPE (Low linear Density Poly Ethylene) of 4 mm thickness, self-pigmented. Ladder should have reinforcement to maintain strength and avoid bending. The top surface of the ladder should be such that it should not deserve any kind of skiddy movement. Ladder stand shall be made from of 25 mm NB „B” class GI pipe and 50 x 10 MS flat. All pipes, flat shall be powder coated to avoid rusting.

104) FRP LADDER 2.1 MTR. HT(MAPS)



The ladder shall be made from FRP (Fiber Reinforced Plastic) / LLDPE (Low linear Density Poly Ethylene) of 4 mm thickness, self-pigmented. Ladder should have reinforcement to maintain strength and avoid bending. The top surface of the ladder should be such that it should not deserve any kind of skiddy movement. Ladder stand shall be made from of 25 mm NB „B” class GI pipe and 50 x 10 MS flat. All pipes, flat shall be powder coated to avoid rusting.

105) SPLIT LEVEL LADDER (MAPS)



This split-level ladder shall be made out of FRP (Fiber Reinforced Plastic) / LLDPE (Low linear Density Poly Ethylene) of 4mm thick. The purpose of this ladder shall be to combine suitably two different sized decks.

106) RAINBOW LADDER (1.5 Mtr Ht.) (MAPS)

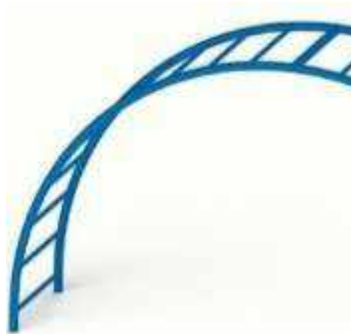

The Rainbow shaped ladder shall be made up of Powder coated GI Pipe. The frame shall be made from 50 x 10 MS flat and 25 mm NB GI „B“ Class pipe with 20 mm NB GI „B“ Class pipe for support. The top surface of the ladder should be such that it should not deserve any kind of skiddy movement. The side railing shall be of Fancy Curve shape. All pipes and flat shall be powder coated to avoid rusting.

107) RAINBOW LADDER (2.1 Mtr Hit) (MAPS)

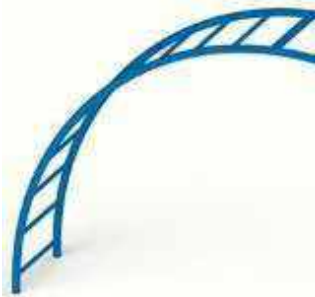

The Rainbow shaped ladder shall be made up of Powder coated GI Pipe. The frame shall be made from 50 x 10 MS flat and 25 mm NB GI „B” Class pipe with 20 mm NB GI „B” Class pipe for support. The top surface of the ladder should be such that it should not deserve any kind of skiddy movement. The side railing shall be of Fancy Curve shape. All pipes and flat shall be powder coated to avoid rusting.

108) NET CLIMBER (0.9 Mtr Ht.) (MAPS)

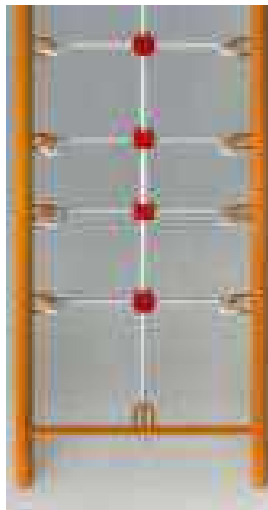

The climber providing exercise, shall be made up of 18 mm diameter Nylon rope attached by specially designed Nylon Ball clamps. These ropes shall be provided with pipe frame fabricated from 25 mm NB GI „B” Class with 12 mm die M.S hooks. 50 x 10 MS flat welded with hook for clamping net purpose. The frame shall be grouted to the ground using standard angle of 25 x 25 x 5 mm thick.

109) NET CLIMBER (1.5Mtr Ht.) (MAPS)

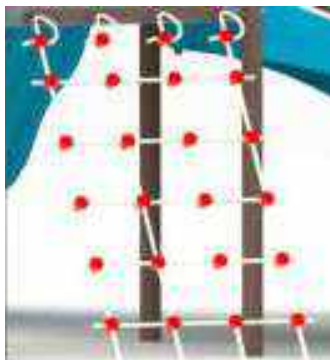

The climber providing exercise, shall be made up of 18 mm diameter Nylon rope attached by specially designed Nylon Ball clamps. These ropes shall be provided with pipe frame fabricated from 25 mm NB GI „B“ Class with 12 mm die M.S hooks. 50 x 10 MS flat welded with hook for clamping net purpose. The frame shall be grouted to the ground using standard angle of 25 x 25 x 5 mm thick.

110) NET CLIMBER (2.1 Mtr Ht.) (MAPS)



The climber providing exercise, shall be made up of 18 mm diameter Nylon rope attached by specially designed Nylon Ball clamps. These ropes shall be provided with pipe frame fabricated from 25 mm NB GI „B“ Class with 12 mm die M.S hooks. 50 x 10 MS flat welded with hook for clamping net purpose. The frame shall be grouted to the ground using standard angle of 25 x 25 x 5 mm thick.

111) SKY ROCKER (MAPS)



Ground Space: 2.1 Mtr x 0.3 Mtr

Safe Play Area: 3.3 Mtr x 2.7 Mtr

Structure & Bush: This item shall be made up of 40 NB B Class GI Pipe. The main frame support shall be made from 80 NB B Class GI Pipe. The top pipe shall be inserted into a nylon bush which gives the rider a swinging experience.

112) MULTI SEATER SEE SAW (MAPS)



REC. AGE: - 3 - 10 Yrs.

THE AREA: - 3 M X 0.5 M

SAFE PLAY AREA: - 4 M X 1.5 M

This item shall be a good entertainment for the children. The lever of the see-saw shall be made from 80 mm NB "B" Class G.I. Pipe. See saw seat shall be made of FRP (Fiber Reinforced Plastic) / LLDPE (Low linear Density Poly Ethylene) 2 mm thickness. The lever shall be fitted on 50 mm NB "B" Class G.I. Pipe and Bush Bearing shall be made from simless pipe fitted in 80 mm NB "B" Class G.I. Pipe. See saw lever shall be welded with 200 x 150 x 5 MS plate for Nut bolting with stand. All pipes, flat shall be powder coated to avoid rusting.

TECHNICAL SPECIFICATIONS M&E

113) STANDARD SEE – SAW(MAPS)



Ground Space: 2.1 Mtr x 0.5 Mtr

Safe Play Area: 3.1 Mtr x 1.5 Mtr

Structure: The horizontal support of the see saw shall is made of 40 NB B Class GI pipe and handle is made of 20 NB B Class GI pipe. Stand made from 50 NB B Class GI pipe with lubricating bush system.

Seat, Bearing & Pin: Seat of See-Saw is made of FRP/ roto moulding process with the wall thickness of 3/5mm. Bearing 6006ZZ used Housing 70 x 50 mm Seamless Pipe. Centre Pin is 32 mm of SAE8620 material.

Caps, Nut Bolts: All Nut Bolts are G.I / M.S/ Stainless Steel material. Closing Caps are made up of LLDPE / HDPE /M.S. Nylon cap to protect from rain and dust.

Powder Coating: The Equipment shall be Powder coated of at least 30-50 microns thickness using AkzoNobel /Berger /Prime make or equivalent.

114) CONICAL PAD LADDER (0.9 M) (MAPS)

The Pads of this Ladder shall be made from FRP (Fiber Reinforced Plastic) / LLDPE (Low linear Density Poly Ethylene) 3 mm thickness. The ladder shall be supported by 40 mm NB GI" B" class pipe. The pipe shall be grounded by C channel of 75x40x5 mm thick. The Pad shall be fixed to the pipe on a circular plate of 5 mm thick with the help of Nut Bolts. All metal shall be powder coated to avoid rusting.

115) SLIDE ENTRY (MAPS)



The slide entry module shall be made up of 3 mm thick of FRP (Fiber Reinforced Plastic) / LLDPE (Low linear Density Poly Ethylene) with self-pigmented. It should be specially

TECHNICAL SPECIFICATIONS M&E

designed in such a manner, no any sharp edge at any site of entrance, it causes safe of the child. It shall be supported by platform with 20 mm NB GI "B" class pipe and 80 mm NB and 80 (mm) x 20(mm) nylon clamp. All pipes shall be powder coated to avoid rusting.

116) CURVE BRIDGE WITH RAILING (2.4 M): (MAPS)



The bridge shall be made from FRP (Fiber Reinforced Plastic) / LLDPE (Low linear Density Poly Ethylene) with 4 mm thick. The railing provided shall be made from FRP (Fiber Reinforced Plastic) / LLDPE (Low linear Density Poly Ethylene) and supported by 20 mm NB „B" class GI pipe and clamped with 80 mm NB and 80 (mm) x 20(mm) nylon clamp. All pipes shall be powder coated to avoid rusting.

117) FIRE MAN POLE (MAPS)

Main vertical structure of this item shall be made of 40 mm NB GI "B" class pipe and horizontal structure shall be made of 25 mm NB GI "B" class pipe. All pipes shall be powder coated to avoid rusting

118) PLATFORM EXT. FOR SPIRAL SLIDE (MAPS)

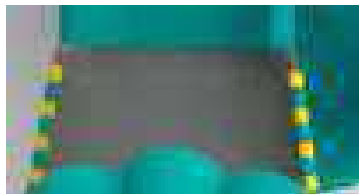

The extension for spiral slide shall be made from fibre reinforced plastic of 4 mm thick. It shall be used to connect the platform to the slide. It shall have a FRP (Fiber Reinforced Plastic) / LLDPE (Low linear Density Poly Ethylene) railing for safety. Railing shall be made up of FRP (Fiber Reinforced Plastic) / LLDPE (Low linear Density Poly Ethylene) and shall be supported by 20 mm NB GI "B" Class pipe clamped to the vertical support pipe.

119) SPIRAL SLIDE'S EXTENTION LANDING (MAPS)



The spiral slide's landing extension shape should be given in such a manner that it will not give any jerk or bump to the rider. The chute has its end such as it causes safe landing of the child. The landing portion should be in horizontal with respect to the ground. The landing support used shall be made up of 25 B Class GI pipes. The pure polyester powder coating shall be done on the pipes.

120) SPIRAL SLIDE'S UMBRELLA (MAPS)



UMBRELLA them shall be attractive, it shall be made of FRP (Fiber Reinforced Plastic) / LLDPE (Low linear Density Poly Ethylene) with thickness of 2 mm. Character. Attached this teaming on Deck pipe anywhere for specially children attraction.

121) EAGAL (MAPS)



EGAL them shall be attractive, it shall be made of FRP (Fiber Reinforced Plastic) / LLDPE (Low linear Density Poly Ethylene) Character of this teaming attached on Deck for specially children attraction.

122) ARC FRAME (CANOPY) (MAPS)

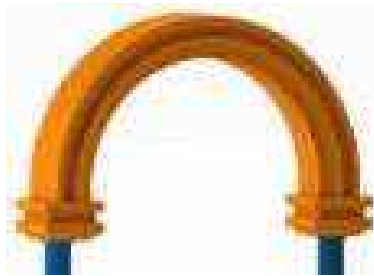

This item shall be completely made with FRP (Fiber Reinforced Plastic) / LLDPE (Low linear Density Poly Ethylene) of 2-3 mm thickness.

123) FRP WIND MILL (MAPS)

This item shall be completely made with FRP (Fiber Reinforced Plastic) / LLDPE (Low linear Density Poly Ethylene) of 3- 4 mm thickness.

124) FRP FAN (MAPS)

This item shall be completely made with FRP (Fiber Reinforced Plastic) / LLDPE (Low linear Density Poly Ethylene) of 3-4 mm thickness.

125) Plain Bridge Railing – MAPS



The railing is made from low density polymer in rotomolding. It has thickness of 4/5mm. And is supported by 20 NB GI pipes clamped to the vertical support pipe.

126) 0.9 Mtr Straight tube Slide with Slide Entry



The Straight tube slide is made up by bi-axial rotational molding process with the wall thickness of 4/5mm with UV stabilized Linear Low Density Polyethylene. Material which gives it a attractive look. And the landing support is made up of 25NB GI pipe. The Straight tube slide Entry support is made up of 20NB GI pipe.

127) 1.5 Mtr Straight tube Slide with Slide Entry



TECHNICAL SPECIFICATIONS M&E

The Straight tube slide is made up by bi-axial rotational moulding process with the wall thickness of 4/5mm with UV stabilized Linear Low Density Polyethylene. Material which gives it a attractive look. And the landing support is made up of 25NB GI pipe. The Straight tube slide Entry support is made up of 20NB GI pipe.

128) 2.1 Mtr Straight tube Slide with Slide Entry



The Straight tube slide is made up by bi-axial rotational moulding process with the wall thickness of 4/5mm with UV stabilized Linear Low Density Polyethylene. Material which gives it a attractive look. And the landing support is made up of 25NB GI pipe. The Straight tube slide Entry support is made up of 20NB GI pipe.

129) 2.7 Mtr Straight tube Slide with Slide Entry



The Straight tube slide is made up by bi-axial rotational moulding process with the wall thickness of 4/5mm with UV stabilized Linear Low Density Polyethylene. Material which gives it a attractive look. And the landing support is made up of 25NB GI pipe. The Straight tube slide Entry support is made up of 20NB GI pipe.

130) 1.5 Mtr Straight Slide with Slide Entry



The Straight slide entry is made up by bi-axial rotational moulding process with the wall thickness of 4/5mm with UV stabilized Linear Low Density Polyethylene. Material which gives it a attractive look. And the landing support is made up of 25NB GI pipe. And the slide Entry support is made up of 20NB GI pipe.

131) 1.5 Mtr Spiral tube Slide with Slide Entry



The spiral tube slide is made up by bi-axial rotational moulding process with the wall thickness of 4/5mm with UV stabilized LLDPE material which gives it a attractive look. The supports for the slide are designed by keeping in mind the strength and as well as the aesthetics of the slide. The main support is made up of 50 NB GI pipe. And The Spiral tube slide Entry support is made up of 20NB GI pipe.

132) 2.1 Mtr Spiral tube Slide with Slide Entry



The spiral tube slide is made up by bi-axial rotational moulding process with the wall thickness of 4/5mm with UV stabilized LLDPE material which gives it a attractive look. The supports for the slide are designed by keeping in mind the strength and as well as the aesthetics of the slide. The main support is made up of 50 NB GI pipe. And The Spiral tube slide Entry support is made up of 20NB GI pipe.

133) 1.5 Mtr Spiral Slide with Slide Entry



The slide is completely made up of one piece rotational molding process with the wall thickness of 4/5mm with UV stabilized Linear Low Density Polyethylene. The material is mixed with UV stabilized food grade to make it UV resistance. The entry module of the slide is different from the other as it looks like as if going through a tunnel and then sliding through the slide. And the landing support is made up of 25NB GI pipe.

134) 1.5 Mtr Wave Slide with Slide Entry



The Wave slide & Slide entry is made up by bi-axial rotational molding process with the wall thickness of 4/5mm with UV stabilized Linear Low Density Polyethylene. Material which gives it a attractive look. And the landing support is made up of 25NB GI pipe. And the slide Entry support is made up of 20NB GI pipe. Landing support is made up of 25NB GI pipe.

135) VERTICAL LOOP CLIMBER 0.9 MTR. (MAPS)

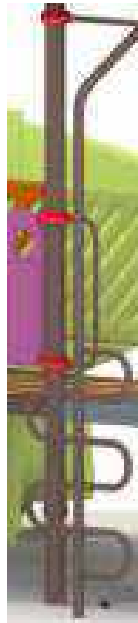

The vertical loop climber shall be made of 25 NB GI pipe supported with 40 NB GI center support pipe with powder coating done on it. The climber is attached to the platform with a GI coating plate of 25x10 mm thick on it with the help of bolts.

136) VERTICAL LOOP CLIMBER 1.5 MTR. (MAPS)



The vertical loop climber shall be made of 25 NB GI pipe supported with 40 NB GI center support pipe with powder coating done on it. The climber is attached to the platform with a GI coating plate of 25x10 mm thick on it with the help of bolts.

137) VERTICAL LOOP CLIMBER 2.1 MTR. (MAPS)



TECHNICAL SPECIFICATIONS M&E

The vertical loop climber shall be made of 25 NB GI pipe supported with 40 NB GI center support pipe with powder coating done on it. The climber is attached to the platform with a GI coating plate of 25x10 mm thick on it with the help of bolts.

138) TRIANGULAR DECK -2.1 (MAPS)



The platform is made up of Fiberglass Reinforced Plastic 4/5mm th with anti-skid surface. The top the vertical supports of the platform are made up of 80 NB GI pipes.

139) OCTAGONAL DECK - 1.5 (MAPS)



The platform is made up of Fiberglass Reinforced Plastic 4/5mm th with anti-skid surface. The top the vertical supports of the platform are made up of 80 NB GI pipes.

140) OCTAGONAL DECK-2.1 (MAPS)



The platform is made up of Fiberglass Reinforced Plastic 4/5mm th with anti-skid surface. The top the vertical supports of the platform are made up of 80 NB GI pipes.

141) MULTI ACTIVITY PLAY SYSTEMS – VERTICAL NET ASSEMBLY 1.5 MTR

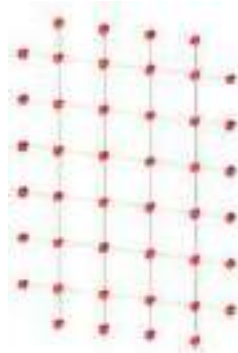

The climber providing exercise, shall be made up of 18 mm diameter Nylon rope attached by specially designed Nylon Ball clamps. These ropes shall be provided with pipe frame fabricated from 25 mm NB GI „B“ Class pipe with 12 mm dia M.S hooks. 50 x 10 MS flat welded with hook for clamping net purpose. The frame shall be grouted to the ground using standard angle of 25 x 25 x 5 mm thick.

142) MULTI ACTIVITY PLAY SYSTEMS – VERTICAL NET ASSEMBLY 2.1 MTR

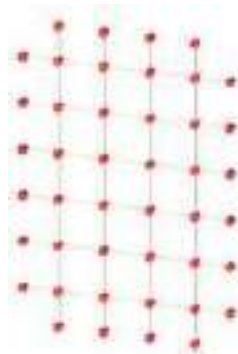

The climber providing exercise, shall be made up of 18 mm diameter Nylon rope attached by specially designed Nylon Ball clamps. These ropes shall be provided with pipe frame fabricated from 25 mm NB GI „B“ Class pipe with 12 mm dia M.S hooks. 50 x 10 MS flat welded with hook for clamping net purpose. The frame shall be grouted to the ground using standard angle of 25 x 25 x 5 mm thick

143) MULTI ACTIVITY PLAY SYSTEMS – VERTICAL NET ASSEMBLY 3 MTR

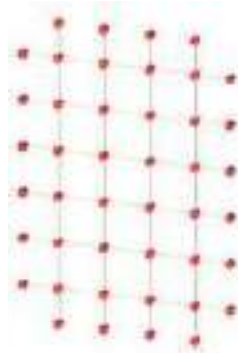

The climber providing exercise, shall be made up of 18 mm diameter Nylon rope attached by specially designed Nylon Ball clamps. These ropes shall be provided with pipe frame fabricated from 25 mm NB GI „B” Class pipe with 12 mm die M.S hooks. 50 x 10 MS flat welded with hook for clamping net purpose. The frame shall be grouted to the ground using standard angle of 25 x 25 x 5 mm thick

144) ROTO / FRP RAILING (MAPS)



The railing shall be made from FRP (Fiber Reinforced Plastic) / LLDPE (Low linear Density Poly Ethylene) and shall be supported by 20 mm NB „B” class GI pipe and clamped with 80 mm NB and 80 (mm) x 20(mm) nylon clamp. All pipes shall be powder coated to avoid rusting.

145) MULTI ACTIVITY PLAY SYSTEMS –FRP/ ROTO RAILING SLIM



The railing shall be made from FRP (Fiber Reinforced Plastic) / LLDPE (Low linear Density Poly Ethylene) and shall be supported by 20 mm NB „B“ class GI pipe and clamped with 80 mm NB and 80 (mm) x 20(mm) nylon clamp. All pipes shall be powder coated to avoid rusting.

146) MULTI ACTIVITY PLAY SYSTEMS –FRP/ ROTO RAILING SMALL



The railing shall be made from FRP (Fiber Reinforced Plastic) / LLDPE (Low linear Density Poly Ethylene) and shall be supported by 20 mm NB „B“ class GI pipe and clamped with 80 mm NB and 80 (mm) x 20(mm) nylon clamp. All pipes shall be powder coated to avoid rusting.

147) MULTI ACTIVITY PLAY SYSTEMS – FRP / ROTO GEOMATRICAL RAILING

The railing shall be made from FRP (Fiber Reinforced Plastic) / LLDPE (Low linear Density Poly Ethylene) and shall be supported by 20 mm NB „B“ class GI pipe and clamped with 80 mm NB and 80 (mm) x 20(mm) nylon clamp. All pipes shall be powder coated to avoid rusting.

148) RAINDEER HEAD (MAPS)



Deer head"stheaming are to be attractive design, it shall be made of FRP (Fiber Reinforced Plastic) / LLDPE (Low linear Density Poly Ethylene) with thickness of 2 mm. This theaming shall be attached on Canopy,,s Top. Deer Head's height - 600 mm, length - 600 mm and Width - 540 mm. i.e. (600 x 600 x 540) mm.

149) CIRCULAR SWING (MAPS)



Ground Space: 1.7 Mtr x 1.5 Mtr

Safe Play Area: 2.7 Mtr x 2.7 Mtr

Structure: The main pipe is of 40 NB B Class GI pipe & Top bar is of 50 NB B Class GI Pipe & the frame of swing is made of 25 NB B Class GI Pipe & 15 NB B Class GI Pipe. The main pipe & top bar pipe is attached with junction box which is made of 4mm MS plate with GI plating. Seat : The swing contains two seat which is made of moulded plastic in ROTO /FRP moulding process. The platform for keeping foot is made of aluminium chequered plate and bearing assembly shall be made. Caps, Nut Bolts: All Nut Bolts are G.I / M.S/ Stainless Steel material. Closing Caps are made up of LLDPE / HDPE /M.S. Nylon cap to protect from rain and dust. Powder Coating: The Equipment shall be Powder coated of at least 30-50 microns thickness using Akzonobel /Berger /Prime make or equivalent.

150) MULTI ACTIVITY PLAY SYSTEMS – CONECTING SLANT LADDER

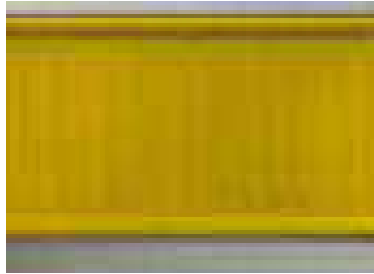

The Platform of plain bridge shall be made of FRP (Fiber Reinforced Plastic) / LLDPE (Low linear Density Poly Ethylene) of 4 mm thick with railing attached to it. The railing shall be made From GI pipe and shall be supported by 20 mm NB „B” class GI pipe and clamped with 80 mm NB and 80 (mm) x 20(mm) nylon clamp. All pipes shall be powder coated to avoid rusting

151) MULTI ACTIVITY PLAY SYSTEMS – CONECTING SLANT LADDER RAILING



The Platform of plain bridge shall be made of FRP (Fiber Reinforced Plastic) / LLDPE (Low linear Density Poly Ethylene) of 4 mm thick with railing attached to it. The railing shall be made from GI Pipe and shall be supported by 20 mm NB „B” class GI pipe and clamped with 80 mm NB and 80 (mm) x 20(mm) nylon clamp. All pipes shall be powder coated to avoid rusting

152) MULTI ACTIVITY PLAY SYSTEMS –SNAKE LADDER 1.5 MTR



The Snake ladder shall be made up of Powder coated GI Pipe. The frame shall be made from 50 x 10 MS flat and 25 mm NB GI „B” Class pipe with 20 mm NB GI „B” Class pipe for support. The top surface of the ladder should be such that it should not deserve any kind of skiddy movement. The side railing shall be of Fancy Curve shape. All pipes and flat shall be powder coated to avoid rusting.

153) MULTI ACTIVITY PLAY SYSTEMS –SNAKE LADDER 2.1 MTR



The Snake ladder shall be made up of Powder coated GI Pipe. The frame shall be made from 50 x 10 MS flat and 25 mm NB GI „B” Class pipe with 20 mm NB GI „B” Class pipe for support. The top surface of the ladder should be such that it should not deserve any kind of skiddy movement. The side railing shall be of Fancy Curve shape. All pipes and flat shall be powder coated to avoid rusting.

154)MULTI ACTIVITY PLAY SYSTEMS – RUBBER NET CLIMBER



The climber providing exercise, shall be made up of 18 mm diameter Nylon rope and GI chain and 15 NB GI pipe ,Rubber coating attached by specially designed Nylon Ball clamps. These ropes shall be provided with pipe frame fabricated from 25 mm NB GI „B” Class pipe with 12 mm dia M.S hooks. 50 x 10 MS flat welded with hook for clamping net purpose. The frame shall be grouted to the ground using standard angle of 25 x 25 x 5 mm thick

155) MULTI ACTIVITY PLAY SYSTEMS – FRP /ROTO ROCK SCRAMBLER 1.5 MTR



Ground Space: 1.5 Mtr x 2.2 Mtr

Safe Play Area: 2.8 Mtr x 4.6 Mtr

Structure & Platform: The main frame is made from 40 NB B Class GI Pipe. The rock climber is a combination of both rock climber. The platform of the rock climber is made up of 4 mm thick FRP (Fiber Reinforced Plastic) / LLDPE (Low linear Density Poly Ethylene). The rocks shall be bolted on same platform, with a gradient of 65 degree from the ground. The main pipe is attached Caps, Nut Bolts: All Nut Bolts are G.I / M.S material. Closing Caps are made

TECHNICAL SPECIFICATIONS M&E

up of LLDPE / HDPE /M.S. to protect from rain and dust. Powder Coating: The Equipment shall be Powder coated of at least 30-50 microns thickness using Akzonobel /Berger /Prime make or equivalent.

156) MULTI ACTIVITY PLAY SYSTEMS – FRP /ROTO STRAIGHT JOINING SLIDE 1.5 MTR



The Straight joining slide shall be made of FRP (Fiber Reinforced Plastic) / LLDPE (Low linear Density Poly Ethylene) of 4 mm thick. The Wave shape should be in such a manner that it will not give any jerk or bump to the rider. The chute has its end such as it causes safe landing of the child. The landing portion should be in horizontal with respect to the ground. There should be Sliding „H” support shall be made from 25 mm NB „B” class GI pipe and 25 x 10 MS flat. All pipes shall be powder coated to avoid rusting.

157) MULTI ACTIVITY PLAY SYSTEMS – FRP /ROTO DELUXE PLAIN SLIDE 1.5 MTR



The Deluxe plain slide shall be made of FRP (Fiber Reinforced Plastic) / LLDPE (Low linear Density Poly Ethylene) of 4 mm thick. The Wave shape should be in such a manner that it will not give any jerk or bump to the rider. The chute has its end such as it causes safe landing of the child. The landing portion should be in horizontal with respect to the ground. There should be Sliding „H” support shall be made from 25 mm NB „B” class GI pipe and 25 x 10 MS flat. All pipes shall be powder coated to avoid rusting.

158) MULTI ACTIVITY PLAY SYSTEMS – FRP /ROTO DELUXE PLAIN SLIDE 2.1 MTR



The Deluxe plain slide shall be made of FRP (Fiber Reinforced Plastic) / LLDPE (Low linear Density Poly Ethylene) of 4 mm thick. The Wave shape should be in such a manner that it will not give any jerk or bump to the rider. The chute has its end such as it causes safe landing of the child. The landing portion should be in horizontal with respect to the ground. There should be Sliding „H“ support shall be made from 25 mm NB „B“ class GI pipe and 25 x 10 MS flat. All pipes shall be powder coated to avoid rusting.

159) MULTI ACTIVITY PLAY SYSTEMS – FRP /ROTO DELUXE WAVE SLIDE 1.5 MTR



The Deluxe Wave slide shall be made of FRP (Fiber Reinforced Plastic) / LLDPE (Low linear Density Poly Ethylene) of 4 mm thick. The Wave shape should be in such a manner that it will not give any jerk or bump to the rider. The chute has its end such as it causes safe landing of the child. The landing portion should be in horizontal with respect to the ground. There should be Sliding „H“ support shall be made from 25 mm NB „B“ class GI pipe and 25 x 10 MS flat. All pipes shall be powder coated to avoid rusting.

TECHNICAL SPECIFICATIONS M&E

160) MULTI ACTIVITY PLAY SYSTEMS – FRP /ROTO DELUXE WAVE SLIDE 2.1 MTR



The Deluxe Wave slide shall be made of FRP (Fiber Reinforced Plastic) / LLDPE (Low linear Density Poly Ethylene) of 4 mm thick. The Wave shape should be in such a manner that it will not give any jerk or bump to the rider. The chute has its end such as it causes safe landing of the child. The landing portion should be in horizontal with respect to the ground. There should be Sliding „H“ support shall be made from 25 mm NB „B“ class GI pipe and 25 x 10 MS flat. All pipes shall be powder coated to avoid rusting.

161) PAINTING:

SprayPainting:

The items shall be scrapped properly. The old paint shall be removed completely, and one coat of red oxide shall be applied and the dent if any shall be removed and filled with best quality putti. Finally, two coats of best quality approved shade of enamel paint or powder coating shall be applied in perfect manner..

PLAY APPARATUS WORK PROCESS GENERAL MATERIAL SPECIFICATION:

1) MATERIALS:

All materials shall be of first grade quality as per specified standards. The company should follow all the procedures of ISO 2000: 9001 standards in attempt to get certification.

(i) G.I. PIPES:

The G.I. Pipe quality and approved make of Tata / Jindal / Bushan / Kalinga / Louts /Siddhartha of I 1239 (Part I) 1979.

(ii) M.S. ANGLE: All M.S. Angle shall be as per No.226 of 1975 (latest) approved make shall be standard specifies sufficient strength to hold all kinds of assembly of Playground Equipment's wherever it applicable.

TECHNICAL SPECIFICATIONS M&E

(iii) **ELECTRICAL WELDING RODS:**Electrical welding rods shall be CITO 5 manufactured by Advani Oerliken or Sunarc equivalent. The welding rods shall not be kept in open environment much before in use as it may get affected by water vapour from the air which may result in priority defect in the weld. Thus it reduces the weld strength.

(iv) **NUT BOLTS & OTHER FASTENERS :**Galvanized iron nuts, bolts, and other fasteners must be used for all moving and non-moving type of play Equipments. All the Fasteners used shall be standard ones.

2) JOINTING:

The joining work shall be done by Metal Inert Gas (MIG) welding process where Carbon Dioxide (CO₂) used as the inert gas. There shall not be any longitudinal joint to make up the length in any member of the apparatus, unless otherwise stated or permitted. The welded joints shall be ground with electric surface grinder and finally polished the ground surface shall be then finished with epoxy sealant of m-seal brand. utmost care taken while welding to ensure that won't be any under cuts or foreign particles entrapment or hydrogen embrittlement in the welded joints.

3) BENDING:

During bending operation it ensured that there won't be any deformations in the diameter of the pipe more than 1.2 times the dia. This shall be achieved by use of slip gauges, and the usage of special bending dies suitable for different diameters. All the bending shall be done by using mechanical bending machine, to give the perfect curves. Other non-standard and complicated curves shall be formed manually by using special pipe holding fixtures which shall be capable to give a wide range of shapes to the pipes.

4) DRILLING:

All the holes shall be drilled by the use of specially designed hardened drilling fixtures to ensure repeatability and interchangeability of the components.

5) CUTTING:

All the cutting shall be done by the use of bend saw machine and cross cutting machines to ensure linearity in cutting and exact length.

6) PLATING:

All the plated parts shall be of hot dipped galvanized or electro galvanized which shall be passivated and thickness of all plating shall be ensured to be a minimum of 10 microns.

7) F.R.P MATERIAL:

All the Fibre reinforced Plastics FRP (Fiber Reinforced Plastic) / LLDPE (Low linear Density Poly Ethylene) material shall be processed by the hand laid process which considered to be the best of its type in the wherein the process as follows:

(i) After the preparation of the mould done a layer of gel coat applied which of N.P.G which duly mixed with U.V stabilized pigment to give the required colour to the product.

(ii) Then a coat of G.P resin applied above the surface of the gel coat after it becomes tack free.

TECHNICAL SPECIFICATIONS M&E

(iii) The constitutive layers of C.S.M (chopped strand matt), glass fiber shall be laid down along with resin to the required extend to build up the required thickness in sandwich pattern.

(iv) The back side coating of the resin done to give a smooth finish.

(v) The moulds shall be kept open to dry for a specified duration. The procedure strengthened the F.R.P.

(vi) After the mould completely cured for the specified duration the FRP (Fiber Reinforced Plastic) / LLDPE (Low linear Density Poly Ethylene) removed from the mould. Then all the corners and edges of it shall be ground to make them smooth and harmless from the strands of the glass wool.

8) PAINTING PROCESS:

All the items that to be painted shall be first made free from any burr and welding spots shall be ground to finish and cleaned with degusting chemical solutions and phosphating done, than all the welded joints shall be applied with epoxy sealant to avoid any exposure to atmosphere so that further corrosion will not take place. Besides the sealing process a parts smooth and better aesthetics to the product. The powder sprayed onto the substrate by means of static electric gun at 8000 volts, ensure uniform powder thickness all over. The thickness maintained a minimum of 60 to 80 microns. (Dry films thickness). The coated product then cured in oven at 200 degree Celsius for twenty minutes.

9) INSPECTION:

All the raw materials and parts shall be inspected for any defects like scratches, dents, cracks and similar shortcomings. The in-inspected while working on them by the skilled operators themselves and by the supervisors for matching ability and conformance to the desired dimensions. The Company carries out 100% inspection of the final goods produced for the conformation with specifications. All the part assemblies shall be checked for their matching with corresponding parts and their interchangeability.

10) PACKING:

All the Equipments manufactured, painted and tested for quality shall be then packed to make them ready for dispatch. The packing material generally used shall be of HDP type or it called as Bubble packing. The packing facility provides shock absorbing capacity and damage proofing to the packed product. Many times sample plastic packing used to wrap and tie the product in order to provide dirt and scratch proofing.

TECHNICAL SPECIFICATIONS M&E

SP-ME-TS-48 EPABX

- The equipment shall be electronic type. It shall have microprocessor / micro controller based on Stored Program Control Technique. It shall employ PCM/TDM, 100% non-blocking, digital switching technology.
- The system should be built on a universal slot architecture and modular in design to enable seamless growth, by adding the desired necessary cards as and when required. Any peripheral card can be inserted in any slot of the platform, whereby it is possible to increase or decrease the trunk lines or subscriber lines of the system as per the requirement in future as per mentioned maximum requirement.
- The architecture of the System shall be capable of seamless migration to its maximum capacity by simply adding peripherals cards in the same chassis without compromising function/features of the system. The architecture should be non-stackable eliminating individual power supply for each chassis.
- The system shall have multiple port interfaces such as analog extension lines, digital key phone, IP Extension, C.O. Line, GSM/3G, PRI/E1 and VoIP. All interfaces shall be in the form of expansion cards and can be plugged into the universal slots of the system as and when require in the future.
- It should have set of hybrid cards such as 2 PSTN (Public switched telephone network) +6 Extensions, 2 Digital Extesnion+6 Extensions, 2 PSTN+2 Digital Extension +4 Extensions to save on the resources of universal slots and investment only on the required number of ports.
- The system should retain traditional networks (CO, ISDN,) along with access to VoIP and GSM networks in single platform just by adding expansion cards.
- It should be suitable for DTMF as well as the FSK type of telephone instruments.
- System power supply should be inbuilt and SMPS type, it shall also work on 230 VAC supply.
- The system should support Rack mount, wall mount, and table top mount.
- The system shall have an ISDN Digital platform and shall be compatible with ISDN PRI line of Local Service Provider.
- The system shall have multiple port interfaces such as analog extension lines, digital key phone, IP Extension, C.O. Line, GSM/3G, PRI/E1 and VoIP. All interfaces shall be in the form of expansion cards and can be plugged into the universal slots of the system as and when require in the future.
- Multiple systems at different locations should be able to connect with each other without any link licenses.
- System should have built-in one number of public address port and external music port.
- System should be license-free to use third party SIP phones.

TECHNICAL SPECIFICATIONS M&E

- It should have built-in 15 participant's conference. i.e. 3 conferences of five parties each or 1 conference of 15 parties shall be offered built-in with the platform.
- The system shall have the inbuilt auto attendant facility and shall be able to answer minimum 5 calls simultaneously and should support dial-by-name.
- The offered exchange should be an ISDN & VoIP ready switch. The system platform should always be ready for ISDN & VoIP and only the necessary in skin ISDN & VoIP cards need to be added for functionality.
- The system should support SMPP protocol to send/receive SMS using in-skin GSM SIMs within System. Any software required to send/receive SMS shall also to quote separately.
- The system shall have at least 1 RS232 port for SMDR/ PMS/ CAS Interface.
- The system can be programmed through Analog telephone, Digital key phone, and Ethernet without any external devices.
- The system shall have a built-in remote maintenance facility. The system can be programmed remotely over the internet without any modem required on the PBX side.
- The call ringing sequence would be programmable and have options such as simultaneous, hunting off, round robin and delayed simultaneous.
- Caller line identification (CLI) on Analog and digital/PRI trunks shall be built-in for both DTMF and FSK telephone instrument.
- Detail reports of all system parameters should be generated through the SMDR port of System. External third party Billing software shall not be required for basic report generation. Reports shall be directly saved in PDF format.
- Each port of the system shall be programmable. It shall have programmable features port-wise/extension-wise.
- The system shall support flexible numbering for extensions such as it may have extensions with 1 digit, 2 digits and up to 6 digits numbers as well as in combination of all.
- The system shall have built-in web based software programming tool for system administration.
- Access codes, system timers and access to features shall be programmable.
- Storage of outgoing, incoming and internal call reports shall be generated on SMDR port of the system. It shall also be available online through Ethernet Port.
- The system should have built-in outgoing Call, incoming call and internal call logs.
- System should support dial form the directory. There shall be minimum 900 numbers possible and shall also possible to dial it as an abbreviated number.
- Features given to an extension shall be accessed from any other extension by dialing the secret codes.

TECHNICAL SPECIFICATIONS M&E

- System features shall have class of service, night service, conference, auto diagnostic etc. Class of service shall be unrestricted. STD restricted and semi restricted
- SNTP client should be inbuilt in System
- The system shall have features as CLI based routing, call duration control, least cost routing i.e. time, number or combination of both.
- Extension features shall have an extension to extension call, extension to central office, extension to operator, automatic call back, call transfer, call forward, follow me, executive/secretary, do not disturb, barge-in, raid, Boss ring, Priority, emergency reporting etc.
- The system shall have a conversational recording in the mail box should be available with voice mail system card of System. Conversation recording should be possible on Analog/Digital/IP as well as mobile SIP Smartphone (Android/ iPhone).
- The system must support following features of IP telephony: Dynamic DNS, Registrar Server, Proxy Server, Presence Server, NAT and STUN, VoIP codec G.711u, G.711a, G.723, G.729, G.722.
- The system shall provide IP functionality to support IP extensions and trunks over SIP protocol. It should be possible to support IP Trunks and Extension with the single VoIP expansion card further expansion of VoIP channels shall be possible with an expansion card.
- Varied type of open SIP IP Terminals such as IP Phone, SIP soft phone and Mobile SIP Client shall be supported.
- The VoIP card should have 16/8 channels per card and such multiple cards shall be used to increase the number of VoIP channels.
- IP functionality of the system shall be in the form of in-skin interface card and can be inserted in the any slots on the platform.
- The system shall integrate in-skin voice mail card with 72 hours of storage capacity and dedicated mailbox for each extension. It shall support Expandable storage capacity up to 500 hours.
- The system shall have a conversational recording in the mail box should be available with voice mail system card of System. Conversation recording should be possible on Analog/Digital/IP as well as Mobile SIP Smartphone (Android/ iPhone).
- IP phone operational functionality should be same as Digital Extension of PBX system shall support SNMP System shall support video conferencing over ISDN PRI/BRI System should have capability to support Video call Over IP System should be Fully operational between Temperature -10°C to +50°C (14°F to122°F)
- System should have in-skin Voice Mail System with following features:
- Attend as much as 16 calls simultaneously with flexibility of routing callers to desired extension or delivering information depend upon the selection

TECHNICAL SPECIFICATIONS M&E

- Dial-by-Name to reach the intended user directly without knowing/ remembering extension number
- Selectively allocate voicemails to users with the flexibility of customizable mailbox size and greetings for All/Selective users
- Message wait indication via ring, change in dial-tone, voice message or message wait lamp

TELEPHONE CABLES:

- The telephone cables shall be of approved make and the conductor of all the cables shall be tinned copper of 0.5 mm dia. in size.
- The cables shall be laid in PVC Casing-N-Caping or PVC conduit of MMS (Medium Mechanical Strength) of appropriate size inside cabins and rooms / on the locations as directed and as per the approved cable layout at the site. The rates for the same shall be paid separately as per FME items. The Jelly filled armoured cables shall be laid on the wall fixing the same in perfect manner with the help of saddle and screws in sufficient quantity so as to properly support the cable on the wall. The metallic glands shall be provided at the end of the armoured cable and at the entry of the junction box. The cables to be laid underground shall be jelly filled armoured.
- While laying the underground cable the ground (concrete/asphalted/soft soil) shall be excavated upto a depth of 0.75 meter deep. After laying the cable in approved manner the trenches shall be filled up and reinstated to match the surrounding surface/road. The cost of the same is not included in the rate of cables.
- At the road crossing, the underground cable shall be laid in „B” class G.I. Pipe of appropriate size in the trench to protect the cable from heavy vehicular load. The cost of the same shall be paid separately.

TECHNICAL SPECIFICATIONS M&E

- At floor crossing the cable/cables shall be laid in B class G.I. Piping or in a suitable 18 swg G.I. channel covering firmly secured to the walls as per the direction of site engineer. The height of covering shall be of 2 meter from the floor level for pipe or for G.I. channel. All the holes in the Slab/Wall shall be filled up properly and made good. The T.W.jumpers shall be provided at all points of cable crossing. Casing & capping joints to P.V.C. pipe connected to M.S. Junction boxes shall be through suitable size P.V.C. flexible pipe, properly connected on either side. The cost of the same shall be paid separately.
- The 2 pair PVC cable shall be laid from the extension (provided on table) to the wall through the Aluminum channel of approximate size of 12 mm x 6 mm & thickness of 16 SWG over the floor.



TECHNICAL SPECIFICATIONS M&E

SP-ME-TS-49 SWITCH BOX POINT FOR COMPUTERS THROUGH CASING-CAPPING:

- a) Scope of work includes providing & fixing of PVC switch box. This switch box shall comprise/ consist of eight (8) module PVC box, cover plate, one (1) no. of indicator, one (1) no. of 15Amp. switch & three (3) nos. of five (5) pin - 5/6 Amp. sockets and its internal wiring. Switch box shall be made of Poly Vinyl Chloride (PVC). Switch box shall be fixed to the wall /cabin-partition by self threaded metallic screws & PVC / wooden rawl-plugs for firm support.

Switch box shall be connected with 2 wires of size 4.00sqmm plus one wire of size 2.5sq mm for earthing wire. Wires shall be of 1100 V grade laid through the suitable sized casing capping of approved makes.

Casing-N-Capping and accessories shall be of same make and as per BS 4678 Part IV and I.S. 14927 Part I. The casing-n- capping shall be ISI marked. All the dimensions and thickness shall be as per IS 14927 (Part I & 2).

In casing-N-capping wires, shall be laid in one length without any joint. Casing-N – Capping shall have minimum joints. Instead of internal working sizes, all external dimensions shall be included in specifications.

- b) PVC box, as a access point for both LAN as well as telephone, shall be fixed on the wall by self threaded screws & PVC/wooden rawl-plugs for firm support. This PVC access box shall be of minimum 75mm X 75mm X 35mm deep, with suitable PVC cover plate with provision of RJ11-I/O socket as well as RJ-45-I/O socket. Both RJ11-I/O & RJ-45-I/O modules shall also be fitted in this socket. Telephone cable shall be terminated in the RJ/11-I/O module while LAN or CAT-5E/6 cable shall be terminated in the RJ-45-I/O module, with proper croning.

ALUMINIUM CHANNEL 16 SWG:

Aluminium channel of approximate size of $\frac{3}{4}$ " x $\frac{3}{4}$ " x 1meter long & thickness of 16 SWG over the floor.

EPABX: M. S. Junction Box:

The metallic epoxy powder coated junction boxes of thickness 18 SWG shall be provided with Dual Krone connectors of 10 P & 20 P etc. as per site requirement, having hinged cover with rubber gasket and lockable with panel key. The junction boxes shall have smooth entry holes, so as to affix metal gland for armoured cables and rubber bush for unarmoured PVC cables. The junction boxes connected with underground armoured jelly filled cable shall be properly grounded by providing proper earthing.

TECHNICAL SPECIFICATIONS M&E

SP-ME-TS-50 PROVIDING & FIXING OF CASING-CAPPING LAYING:

Providing & fixing of Casing-n-Capping and accessories shall be done with neatly to suit aesthetic / surrounding. Casing-n-Capping and accessories shall be of same make and as per BS 4678 Part IV and I.S. 14927 Part I. All the dimensions and thickness shall be as per IS 14927 (Part I & 2)

Casing-N-Capping shall have minimum joints. Instead of internal working sizes, all external dimensions shall be included in specifications. The sizes for casing-n-capping shall be used as per following: - width : (i) 20mm (ii) 25mm (iii) 12 mm and height - 12mm & thickness - 1.2 mm. These shall be screwed to the wall / ceiling, at a distance of 30 cms to 45 cms. The accessories shall be in conjunction with casing-n-capping.



PROVIDING & FIXING OF CASING-CAPPING LAYING

TECHNICAL SPECIFICATIONS M&E

SP-ME-TS-51 PROVIDING & FIXING OF PVC CONDUIT LAYING:

Providing & Fixing of only rigid PVC conduit pipes conforming to IS: 9537 (Part-III) marked 'Medium' shall be used for surface mounting wiring & PVC conduits marked 'Heavy' shall be used for concealed wiring. All PVC accessories shall be conforming to I. S. 3419.

The PVC conduit pipes shall be ISI marked. All the dimensions and thickness shall be conforming to relevant IS. The wires shall be laid through these conduits, wherever required. Conduits shall have minimum joints. Instead of internal working sizes, all external dimensions shall be included in specifications.

PVC conduit of appropriate size on the locations as directed and as per the approved layout. The PVC conduit shall be of Precision, Asian or Diamond make. The PVC conduit shall run on wall in perfect manner with proper jointing at the corner. The necessary jointing pieces e.g. bend, tees, PVC flexible pipe, PVC glands/rubber bush (at the cable entry of junction box) & teakwood jumpers at (cable crossings) etc. shall be provided as per the site condition.

The conduits shall be used as per following: - (i) 20mm (ii) 25mm (iii) 12 mm The conduits shall be fixed with GI saddles & GI spacers which shall be properly screwed to the wall / ceiling, at a distance of 30 cms. to 45 cms., by self threaded metallic screws & PVC/wooden rawl-plugs for firm support.



PVC CONDUIT

SP-ME-TS-52 Public Address System:

Amplifiers

- Power output: 160W RMS at 10% THD /220W RMS Max.
- Input Channels: Mic. : 5xMic 0.65mV/4.7k Ω
- Aux : 2xAux 100mV/470k Ω
- 1x Line 1V/50k Ω
- Freq.Resp : 50-15,000Hz \pm 3db
- Tone controls : Bass : \pm 10db at 100 Hz
- Speaker output : 4 Ω , 8 Ω , 70V&100V

Ceiling & Wall Speakers :

- Input Power : 6W RMS
- Power Taps : 6/3/1.5W on 100V
- Freq. Resp. : 60-15,000 Hz
- SPL(1W/1m) : 92db
- Dim.(mm) : Apprx.W262xH262xD128mm
- Wt. : 1.5 kg

Microphone Stand :

- Type : Floor Stand
- Height: Appr.920-1500mm
- Base dia.: Appr. 230Mm
- Weight: As min. as 4.41 kg

Microphones :

All purpose PA microphone reproducing intelligible, crisp and a bright sound. Suitable for multi-purpose PA installations.

Supplied with quick detachable holder with 3-pin professional XLR connector & 6 mtrs.

Shielded low noise cable.

TECHNICAL SPECIFICATIONS M&E

Conference System:

Central Amplifier -1 Unit,

Delegate Unit -1 Unit,

Chairman Unit -1 Unit.

The conference system shall provide the much required sound reinforcement at meetings while eliminating problems of poor intelligibility and acoustic feedback. The system shall be ideal for use in a variety of applications in Boardrooms, Large conference Halls as well as open conferencing in convention centers.

The system shall have following:

- Highly sensitive 16" long goose neck microphone for comfortable sharing by two delegates.
- Bright and clear ring LED indicator.
- Compact and attractive die cast aluminium cabinet in a unique profile.
- Headphone output available for each unit.
- Automatic Mic off feature in Delegates unit.
- Unique send / Return facility through a stereo jack.
- Chairman Unit shall have Priority Switch.
- Record & Playback the messages with the Secretary Unit.
- AC Mains & 24 V DC operation.
- Central Amplifier shall be 19" rack mountable.
- Three mic inputs and one Aux. Input for the various user applications.
- 50W PA Amplifier for adequate sound reinforcement.
- System expansion possible through the Conference Expansion Unit .
- Conference System can be installed in a bus bar arrangement by using Junction Boxes .

Ceiling speaker :-

- Input Power: 6W RMS
- Power taps: 6/3/1, 5W on 100V
- Freq. Resp. : 60/15,000Hz.
- SPL (1W/1m) : 92dB

TECHNICAL SPECIFICATIONS M&E

SP-ME-TS-53 Projector:

Native Resolution	WXGA (1280 x 800)
Brightness	3300AL
Contrast Ratio	13000:1
Display Color	1.07 Billion Colors
Lens	F=2.56-2.68, f=22-24.1 mm
Aspect Ratio	Native 16:10 (5 aspect ratio selectable)
Throw Ratio	1.55-1.7 (87"@2.9m)
Image Size (Diagonal)	60"~300"
Zoom Ratio	1.1:1
Lamp Type	190W
Lamp Mode (Normal/ Eco/ SmartEco/ LampSave)	4500/6000/6500/10000 hours
Keystone Adjustment	1D, Vertical +/- 40 degrees
Projection Offset	100% ±5%
Resolution Support	VGA(640 x 480) to WUXGA_RB(1920X1200) *RB=Reduced blanking
Horizontal Frequency	15~102KHz
Vertical Scan Rate	23~120Hz
Compatibility	HDTV Compatibility: 480i, 480p, 576i, 576p, 720p, 1080i, 1080p
	Video Compatibility: NTSC, PAL, SECAM
	Frame Sequential: Up to 720p Frame Packing: Up to 1080p Side by Side: Up to 1080i/p Top Bottom: Up to 1080p

TECHNICAL SPECIFICATIONS M&E

Interface	Computer in (D-sub 15pin) x 2 Monitor out (D-sub 15pin) x 1 Composite Video in (RCA) x 1 S-Video in (Mini DIN 4pin) x 1 HDMI x 1 Audio in (Mini Jack) x 1 Audio out (Mini Jack) x 1 Speaker 2W x 1 USB (Type mini B) x 1 DB-9 pin (RS232) x 1 IR Receiver x1 (Front)
Power	AC100 to 240 V, 50 to 60 Hz
Power Consumption	Normal 270W, Eco 220W, Standby<0.5W
Operating temperature (Operating humidity)	0°C to 35°C / 32°F to 95°F (20% to 80%; no condensation)



Projector

SP-ME-TS-54 CLOSE CIRCUIT TELEVISION SYSTEM (CCTV)

1) DIGITAL VIDEO RECORDER WITH SOFTWARE :-

Features:

- Support HD/Analog/IP Video input
- All channel 1080N/720P Real time Recording
- H.264 dual-stream Video Compression
- HDMI / VGA Simultaneous Video Output
- Support min 4 SATA HDD up to max.16TB, 2 USB2.0
- Detailed Specifications:
- Processor : Embedded processor
- Operating System : Embedded LINUX
- Two-way Talk : Reuse audio input/output channel 1
- User Interface: GUI
- Video Input: 4 channel or 8 channel or 16 channel, BNC
- Video Output: 1 HDMI, 1 VGA
- Video Standard: Analog: NTSC/PAL and 1080P/720P HD Camera.
- Video Compression: H.264 / G.711
- Video Resolution: 1920 × 1080, 1280 × 1024, 1280 × 720, 1024 × 768, 800×600
- Video Recording:
- Main Stream: 1*1080N/720P(1~25/30fps)+15*(1~12/15fps)
960H/D1/HD1/BCIF/CIF/QCIF
- (1~25/30fps), Extra Stream: CIF/QCIF(1~7fps)
- Video Display Split: 1/4/8/9/16
- Privacy Masking: 4 rectangular zones (each camera)
- Audio Input: 4 channel, RCA
- Audio Output:1 channel, RCA
- Motion Detection: supports
- Video Loss: supports
- Alarm Input: 8/16 channel
- Alarm Output: 3 channel
- Hard Disk: 4 SATA port, up to 16TB

TECHNICAL SPECIFICATIONS M&E

- Trigger Events: Recording, PTZ, Tour, Video Push, Email, FTP, Spot, Buzzer & Screen tips
- Recording Mode: Manual, Schedule(Regular(Continuous), MD), Stop
- Search Mode: Time/Date, MD & Exact search (accurate to second)
- Playback: Play, Pause, Stop, Rewind, Fast play, Slow play, Next file, Previous file, Next camera, Previous camera, Full screen, Repeat, Shuffle, Backup, selection, Digital zoom
- Backup Mode : USB Device/Internal SATA burner/Network
- Interface Ports : 1 HDMI, 1 VGA, 2 USB2.0, 1 RS485
- Max User Account : 128 users
- Record Interval : 1~60 min (default: 60 min), Pre-record: 1~30 sec, Post-record: 10~300 sec
- Smart Phone: iPhone, iPad, Android, Windows Phone
- Protocols :HTTP, IPv4/IPv6, TCP/IP, UPNP, RTSP, UDP, SMTP, NTP, DHCP, DNS,
- PPPOE, DDNS, FTP, IP Filter, SNMP, P2P, ONVIF Version 2.4 conformance
- Ethernet: RJ-45 port (10/100M)
- Power Supply : DC12V/4A
- Working Temp: -10 ~+55°C / 10~90%RH / 86~106kpa

2) Analog HD PTZ CCTV Camera

Features:

- 1/3" CMOS Image sensor Minimum 20x Optical and 12x Digital zoom
- WDR, Day/Night(ICR), Ultra DNR
- Up to 255 Presets, 8 Tour, 4 Pattern, 4 Auto scan
- Max 240°/s pan speed, 360° endless pan rotation
- IR Range of 100 Mtr.
- Built-in 2/1 alarm in/out, IP66

Detailed Specification:

Parameter	Requirement
Image Sensor	1/3" CMOS
Effective Pixels	1280(H) x 960(V)
Video Output	1 channel BNC HDCVI high definition video

TECHNICAL SPECIFICATIONS M&E

	output
S/N Ratio	More than 50dB
Minimum Illumination	Color: 0.05Lux@F1.4, B/W: 0.005Lux@F1.4, 0Lux (IR on)
Focal Length	4.7mm~94mm
White Balance	Auto, ATW, Indoor, Outdoor, Manual
Focus Control	Auto / Manual
Close Focus Distance	100mm~ 1000mm
Angle of View	H: 54.1° ~ 3.2°
Electronic Shutter	1/1 ~ 1/30,000s
AGC control	Auto / Manual
Back Light Compensation	BLC / HLC / DWDR
Optical Zoom	20x Minimum
Digital Zoom	12x Minimum
Pan Travel	360° endless, Pan Speed: 0.1° ~ 160°/sec
Tilt Travel	-15° ~ 90°, Tilt Speed: 0.1° ~120°/sec
Presets	255
Preset Speed	Pan: 240° /s; Tilt: 200° /s
Special Features	IR Range upto 100m, Up to 255 Presets, 8 Tour, 4Pattern, 4 Auto scan
Privacy Masking	Up to 24 areas
Power up Action	Auto restore to previous PTZ and lens status after power failure
Time Task	Auto activation of Prese/ Pan/ Scan/ Tour/ Pattern by preset-time
Idle Motion	Activate Preset/ Pan/ Scan/ Tour/ Pattern if

TECHNICAL SPECIFICATIONS M&E

	there is no command in the specified period
Day/Night: IR Cut Filter	Auto(ICR) / Color / B/W

3) Infrared Analog HD Dome camera/ Analog HD Outdoor Bullet camera

Features:

- 1/3" 1.3 MP HQIS Pro Image Sensor
- Max 25/30fps@1.3MP
- DWDR, Day/Night(ICR), AWB, AGC, BLC
- 3.6mm fixed lens (2.8mm, 6mm & Upto 12mm optional lens)
- IR Range of 20 Mtrs.
- OSD Menu, control over coaxial cable, 2D-DNR
- HD and SD switchable
- IP67
- Detailed Specifications:
- Image Sensor : 1/3" 1.3 MP HQIS Pro Image Sensor
- Minimum Illumination: 0.05Lux/F2.0, 0Lux IR on
- Shutter Speed: 1/50s~1/100,000s
- Back Light Comp: WDR
- Lens: 3.6mm (2.8mm, 6mm & Upto 12mm optional lens)
- Video Streaming: 1.3MP@25 fps
- Video Output:1-channel BNC high definition video output/ CVBS standard definition video output (Can switch)
- ICR : Auto(ICR)/Color/B/W
- IR: IR Range of 20 Mtr.
- Operating Temperature: -40°C~+60°C / Less than 95%RH (no condensation)
- Power Source: DC12V±25%
- Power Consumption: Max 2.8W
- Weatherproof Standard : IP67

TECHNICAL SPECIFICATIONS M&E

4) IP Dome/ Fixed Box Camera

Parameter	Requirement
Image Sensor :	1/2.8" Progressive Scan CMOS
Min. Illumination :	0.01Lux @(F1.2,AGC ON), 0.014 Lux @(F1.4,AGC ON), 0 Lux with IR
Shutter Speed :	1/3 s ~ 1/100,000 s
Slow Shutter :	Support
Lens :	2.8 - 12 mm @ F1.4, motorized lens (-Z), angle of view: 106°~35°
Day & Night :	IR cut filter with auto switch
WDR :	120dB
Compression Standard	
Video Compression :	H.264/MJPEG/H.264+
H.264 Type :	Main Profile
Video Bit Rate :	32 Kbps – 16 Mbps
Audio (-S) :	G.711/G.722.1/G.726/MP2L2, 64Kbps(G.711) / 16Kbps(G.722.1) / 16Kbps(G.726) / 32-128Kbps(MP2L2)
Image	
Min. Resolution :	1920 × 1080
Max Frame Rate :	50Hz: Main stream: 25fps(1920 × 1080, 1280 × 960, 1280 × 720); Sub stream: 25fps(352×288), 25fps(640×360)
Image Setting :	Rotate Mode, Saturation, Brightness, Contrast, Sharpness adjustable by client software or web browser
Day/Night Switch :	Auto/ Schedule/ Triggered by Alarm In
Network	

TECHNICAL SPECIFICATIONS M&E

Alarm Trigger :	Tampering alarm, Network disconnect, IP address conflict, Storage exception
Protocols :	TCP/IP, UDP, ICMP, HTTP, HTTPS, FTP, DHCP, DNS, DDNS, RTP, RTSP, RTCP, PPPoE, NTP, UPnP, SMTP, SNMP, IGMP, 802.1X, QoS, IPv6,
General Function :	One-key reset, Anti-flicker, heartbeat, mirror, password protection, privacy mask, watermark, IP address filtering, anonymous access
Standard :	ONVIF (PROFILE S, PROFILE G)
General	
Interface :	1 RJ45 10M/100M Ethernet interface, 1Vp-p composite output (75 Ω/BNC)
Operating Conditions :	-30 °C – 60 °C (-22 °F – 140 °F), Humidity 95% or less (non-condensing)
Power Supply :	12V DC±25%, PoE (802.3af, Class 3), Max. 5.5 W
Ingress Protection :	IP67
IR Range :	20~30 meters

5) IP PTZ camera

- Image Sensor: 1/2.8" CMOS
- Effective Pixels: 1920(H) x 1080(V), 2 Megapixels Minimum
- S/N Ratio: More than 55dB
- Minimum Illumination: Color: 0.05Lux@F1.6; 0Lux@F1.6 (IR on)
- Focal length: 20x optical zoom, 16X Digital zoom
- White Balance: Auto, ATW, Indoor, Outdoor, Manual
- Focus Control: Auto / Manual
- AGC Control: Auto / Manual
- Back Light Compensation: BLC / HLC / WDR(120dB)
- Pan Travel: 0°~360° endless, Pan Speed: 0.1° ~ 300°/sec
- Tilt Travel: -15° ~ 90° auto flip 180°, Tilt Speed: 0.1° ~200°/sec
- Manual Speed: Pan: 0.1° ~300° /s; Tilt: 0.1° ~200° /s

TECHNICAL SPECIFICATIONS M&E

- Presets: 300
- Day/Night IR Cut Filter: Auto(ICR) / Color / B/W
- Video Compression: H.265/H.264 / MJPEG
- Video Streaming: Main stream: 1080P/720P/1.3M(1 ~ 50/60fps) , Sub stream1: D1/CIF(1 ~ 25/30fps) , Sub stream2: 1080P/1.3M/720P/D1/ CIF (1 ~ 25/30fps)
- Networking: RJ-45 (10/100Base-T)
- Protocols: IPv4/IPv6,HTTP,HTTPS,SSL,TCP/IP, UDP, UPnP, ICMP,IGMP,SNMP,RTSP,RTP, SMTP, NTP,DHCP, DNS,PPPOE,DDNS,FTP, IP Filter, QoS ,802.1x, ONVIF, PSIA, CGI
- Alarm: 2/1 channel In/Out
- Operating Temperature: -40°C ~ 70°C
- Weatherproof Standard: IP66
- Power Source: AC24V/3A(±10%), PoE+(802.3at)
- Power Consumption: 13W,23W (IR on)
- Memory: Upto 128GB

6) 16/ 32 & 64 channel 1080P NVR

Features:

- Up to 16/ 32/ 64 channel IP camera input
- Max 320Mbps incoming bandwidth
- H.265/H.264/MJPEG/MPEG4 codec decoding
- Up to 12Mp resolution preview and playback
- Support 8 SATA HDDs up to 48TB, 4 USB(2 USB3.0, 2USB2.0), Support RAID 0/1/5/6/10
- 2 HDMI / VGA simultaneous video output
- Support Multi-brand network cameras

Detailed Specifications:

- Processor: Quad-core embedded processor
- Operating System: Embedded LINUX or Latest windows 10 compatible
- IP Camera Input: 16/ 32/ 64 channel
- Two-way Talk: 1 channel Input, 1 channel Output, RCA
- User Interface: GUI
- Video Output: 2 HDMI (1 HDMI up to 3840x2160, Different Source) , 1 VGA

TECHNICAL SPECIFICATIONS M&E

- Compression: H.265/H.264/MJPEG/MPEG4
- Video Resolution: 1920× 1080, 1280× 1024, 1280× 720, 1024× 768
- Alarm Input: 16 Channel, Low Level Effective, Green Terminal Interface
- Alarm Output: 4 Channel, NO/NC Programmable, Green Terminal Interface
- Hard Disk: 8 SATA III Ports, up to 48TB, 1 eSATA port
- RAID: single, Raid 0/ 1/ 5/ 6/ 10
- Recording Mode: Manual, Schedule(Regular(Continuous), MD, Alarm), Stop
- Search Mode: Time /Date, Alarm, MD and Exact Search (accurate to second)
- Playback: Play, Pause, Stop, Rewind, Fast play, Slow Play, Next File, Previous File, Next Camera, Previous Camera, Full Screen, Repeat, Shuffle, Backup Selection, Digital Zoom
- Backup Mode: USB Device/ Network/ Internal SATA burner/ eSATA Device
- Interface Ports: 2 HDMI, 1 VGA, 4 ports (2 Rear USB3.0,2 Front USB2.0), 1 eSATA port, 1 RS485, 1 RS232, 2 RJ45
- Record Interval: 1~120 min (default: 60 min), Pre-record: 1~30 sec, Post-record: 10~300 sec
- Max User Account: 128 users
- Ethernet: 2 RJ-45 port (10/100/1000Mbps), 2 Ethernet Ports Joint Working or 2 Independent 1000Mbps Ethernet Ports
- Protocols: HTTP, TCP/IP, IPv4/IPv6, UPNP, RTSP, UDP, SMTP, NTP, DHCP, DNS, IP Filter, PPPOE, DDNS, FTP, Alarm Server, IP Search, ONVIF
- Power Supply: single, AC 100~240V, 50/60 Hz
- Power Consumption: <16.7W (without HDD)
- Working Temp: -10 ~+55°C / 10~90%RH / 86~106kpa

7) UPS.

- At least 2KVA
- 2 Hour backup (SMF Battery 12 v 65 Ah 6 nos for 120min battery backup and Rack & Link For 65 Ah 6 nos battery)
- The input voltage range shall be 180 V to 260 V AC
- The output voltage 230 V AC
- The batteries shall be sealed maintenance free of reputed make

8) VIDEO CO-AXIAL CABLES

TECHNICAL SPECIFICATIONS M&E

Co-axial cable of the following minimum specification shall be used indoor in conduits, trunking and cable trays.

Type :RG 6/RG 11/

Impedance :75 Ohms

Conductor (dia) :20 AWG Solid Bare Copper

Insulation :Cellular Polyethylene

Nominal O.D. :0.242"

Shielding :95% Bare Copper Braid

Jacket :Black Flame Retardant PVC

6) CABLE IDENTIFICATION:

(i) All cables are to be clearly marked at each terminated end indicating the camera to which the cable belongs. At intervals of not less than 5 meters, the cable is to be marked "CCTV"

(ii) A cable diagram is to be provided, superimposed on the appropriate floor plan, showing the route taken for each cable. This diagram is to include the locations for camera power supplies and ancillary devices.

(iii) Exposed cables, in back of house areas, are to be enclosed & secured to prevent tampering. Where cables are enclosed in fire rated areas, such as fire stairs and exits, the enclosure is to be similarly fire rated.

Additional items: A

S & i of 16CH NVR with 2 HDD bays:-

Supply and installation of 16CH NVR with 2 HDD bays for connecting to 16 IP cameras stand alone NVR with two slots for Hard disk. The hard disk shall be of 2TB with compatible to window & Mac operating system with USB port for connection.

Supply & inst of 2 TB Hard Disk Drive:-

The hard disk shall be of 2TB with compatible to window & Mac operating system with USB port for connection.

Supply & inst of 18.5" LED Monitor:-

The LED Monitor shall be 18.5 inch in size and flat type with 1920X1080 resolution with aspect ratio

TECHNICAL SPECIFICATIONS M&E

of 16:9. The Monitor shall be provided with USB/HDMI port. The typical brightness shall be 200cd/square meter with color support of 15-18M. The operating voltage shall be 100-230V AC.

Providing voice point:-

Approved make strong box made of either PVC / ABS material, as an access point for both LAN and/or Telephone, shall be fixed on the wall by self threaded screws & PVC/wooden rawl-plugs for firm support. It consists of dust proof shutter. This PVC access box shall have suitable PVC cover plate with provision of 2 Nos of I/O sockets for either RJ-11 and/or RJ-45. Both RJ11-I/O & RJ-45-I/O modules shall also be fitted in this socket, as per requirement. Telephone cable shall be terminated in the RJ/11-I/O module while LAN or CAT-5E/6 cable shall be terminated in the RJ-45-I/O module, with proper croning.

Providing data point:-

Approved make strong box made of either PVC / ABS material, as an access point for both LAN and/or Telephone, shall be fixed on the wall by self threaded screws & PVC/wooden rawl-plugs for firm support. It consists of dust proof shutter. This PVC access box shall have suitable PVC cover plate with provision of 2 Nos of I/O sockets for either RJ-11 and/or RJ-45. Both RJ11-I/O & RJ-45-I/O modules shall also be fitted in this socket, as per requirement. Telephone cable shall be terminated in the RJ/11-I/O module while LAN or CAT-5E/6 cable shall be terminated in the RJ-45-I/O module, with proper croning.

Providing 100 pair MDF :-

Main distribution frame (MDF) /junction box for telephone distribution network shall be rectangular type of box made of min. 0.5 mm thick Aluminum sheet. It shall be designed to accommodate 10 nos of 10-pair PVC krone modules with 1 back mount frame and earthing. The Telephone MDF Box shall have robust lock and key arrangement. Wall mounting arrangement along with necessary providing and fixing of screws/nut bolts, rawl plug, drilling shall be done for its proper installation.

Additional items: B

Access Control System :

Providing & laying UPVC 25mm thk pipes:-

Providing & laying UPVC 25mm thick pipes with screwed sockets, joints, and necessary pvc fittings such as socket, elbows, bends, tees etc., including making/ drilling holes in walls/ slabs and remaking good the damages in original conditions

Supply and fixing of PVC 50mm thk Pipe:

Supplying and fixing of PVC 50mm thick Pipe of SWR Grade of approved company including all necessary fitting fixed with GI Clamp making necessary holes in valets, refilling the same with concrete making good the damaged portions with matching plaster complete in all respects.

Supply & fixing of Open Gate Valve:-

Supply & fixing of Open Gate Valve to be provided only at the entry point of plumbing lines within the toilets or toilet outside shaft reachable area. The gate valve shall be of ISI mark of bronze of 25/40/50mm size. The gate valve shall be threaded type. The wheel shall be of cast iron and spindle & gland nut shall be of bronze.

TECHNICAL SPECIFICATIONS M&E

P and f Angle cock at the below Sink:-

Providing and fixing Angle cock at the below Sink or washbasin rate to be including heavy duty C.P. Water connectors for pillar cock all complete. The angle cock shall be of gun metal of 25/40/50mm size as per IS 318. The angle cock shall be threaded type. The body test pressure shall be 200 PSI.

P and f of heavy duty bottle trap all:-

The bottle trap shall be of 50mm made of brass with chrome plating.

P and fi of heavy duty 4" Waste coupling:-

The waste coupling shall be heavy duty type of 4inch made of brass with chrome plating.

Providing and fixing of Providing and fixing of WC-1 no , Unrinal-1 No & Wash Basin-1 for toilet. WC(Water Closet)::The water closet shall be made of ceramic and shall be floor mounted type. The WC shall be provided with seat cover. The WC shall be provided with water flush system. Urinal Pot::The Urinal pot shall be made of ceramic and shall be wall mounted type. The urinal pot shall be provided with valve type flushing system. Wash Basin::The wash basin shall be made of ceramic and shall be wall mounted type with over flow slot. The wash basin shall be provided with water tap. WC-1 no:-

S&I of SS304 work bech 600 x 600x750 mm :-

Supply & Installation of SS 304 work bench with SS 304 Work Top having 1D 2 S with 1 no. adjustable and removable shelf, body constructed in 1 mm thick SS 304 and door in 0.8 mm thick SS 304 along with Electrical trunking for fixing of switch & socket. The hinges, handles used in table shall be SS 304 grade Size- 600 x 600 x 750 mm HT.

S&I of SS304 work bech 525 x 600 x 750mm:-

Supply & Installation of SS 304 work bench with SS 304 Work Top having 1D 2 S with 1 no. adjustable and removable shelf, body constructed in 1 mm thick SS 304 and door in 0.8 mm thick SS 304 along with Electrical trunking for fixing of switch & socket. The hinges, handles used in table shall be SS 304 grade

Size- 525 x 600 x 750 mm HT.

S&I of SS304 work bech 648 x 600 x 750mm:-

Supply & Installation of SS 304 work bench with SS 304 Work Top having 1D 2 S with 1 no. adjustable and removable shelf, body constructed in 1 mm thick SS 304 and door in 0.8 mm thick SS 304 along with Electrical trunking for fixing of switch & socket. The hinges, handles used in table shall be SS 304 grade

Size- 648 x 600 x 750 mm HT.

S&I of SS304 work bech 585 x 600 x 750mm:-

Supply & Installation of SS 304 work bench with SS 304 Work Top having 1D 2 S with 1 no. adjustable and removable shelf, body constructed in 1 mm thick SS 304 and door in 0.8 mm thick SS 304 along with Electrical trunking for fixing of switch & socket. The hinges, handles used in table shall be SS 304 grade

TECHNICAL SPECIFICATIONS M&E

Size- 585 x 600 x 750 mm HT.

S&I of SS304 work bech 950 x 950 x 750mm:-

Supply & Installation of SS 304 corner unit with SS 304 Work Top having 1 S with 1 no. adjustable and removable shelf, body constructed in 1 mm thick SS 304 and door in 0.8 mm thick SS 304 along with Electrical trunking for fixing of switch & socket. The hinges, handles used in table shall be SS 304 grade

S&I of GI Powder coated work bench:-

Supply & Installation of GI Powder coated work bench (Top Granite) with 1 drawer 2 shutter with 1 no. adjustable and removable shelf body 1 mm and door 0.8 mm with Electrical trunking and switch & socket. Supply & fixing of GI Powder coated work bench with 1D (drawer) 2S (shutter) with 1 no. adjustable and removable shelf, body constructed in 1 mm thick GI powder coated and door in 0.8 mm thick GI powder coated. The table shall be of mat finish with top granite of thickness 18mm

Size- 637 x 600 x 750 mm HT.

S&I of SS 304 Garment Cub with 4 nos :-

Supply & fixing of SS 304 garment cubical with 4 nos of shelf and toughened glass. It consist of 4 nos. nylon type bush at bottom with exhaust system and body constructed in 1 mm thick SS 304 . The hinges, handles used in garment cubical shall be SS 304 grade and table shall be of mat finish. The exhaust system shall be Circular/Cabinet type Inline fan of capacity 200 cfm.

Size-1200 x 450 x 2000 mm ht.

S&I of SS 304 wash basin sink and tap:-

Supply and Installation of wash basin sink in SS 304 construction and same shall be made in 1 mm thickness and with necessary accessories like Tap , Sink .Size- Size-650 x 600 mm

S&I of SS 304 work bech (SS Work Top):-

Supply & Installation of SS 304 work bench with SS 304 Work Top having 1D 2 S with 1 no. adjustable and removable shelf, body constructed in 1 mm thick SS 304 and door in 0.8 mm thick SS 304 along with Electrical trunking for fixing of switch & socket. The hinges, handles used in table shall be SS 304 grade Size- 750 x 600 x 750 mm HT.



CCTV

TECHNICAL SPECIFICATIONS M&E

SP-ME-TS-55 Network Accessories

1) 24 Port Fiber Optic Switch

24 Port +4 10G SFP+ Fiber Optic Switch must have following features or better

- (i) 24 port Giga Ethernet Layer 3 Switch supporting 1000 Base T / ZX/SX/LH
- (ii) must be stackable; Min 9 switches in stack
- (iii) Must support 128Gbps switching fabric
- (iv) Must have min.16Mb
- (v) Must be configurable up to 68K MAC addresses
- (vi) Must support DHCP auto configuration
- (vii) Must support auto negotiating on all ports for full duplex or half duplex
- (x) Must support LACP (Link Aggregation Control Protocol)
- (xi) Must support DHCP Relay
- (xii) IEEE 802.3z 1000BASE-SX, 1000BASE-LX/LH, 1000BASE-ZX, 1000BASE-T
Compliant
- (xiii) Must support Per-VLAN Rapid spanning Tree
- (xiv) Must support Equal cost routing for load balancing and redundancy
- (xv) Advanced IP unicast routing protocols (Open Shortest Path First [OSPF])
- (xvi) Must have Port Based Security, IEEE 802.1x with VLAN assignment. IEEE 802.1x
with voice VLAN Port-based ACLs for Layer 2 interfaces, Dynamic ARP Inspection
- (xvii) Vendor must configure the ports appropriately for the successful commissioning-
- (xviii) System must support and must be configurable on rack. AU accessories and
hardware necessary for configuration on rack must be supplied.
- (xix) Rack must be supplied and the switch must be configured on Rack
- (xx) 3 years on-site Warranty with 98 percent uptime commitment

2) Fiber optic Cable

Fiber Optic Cable must have following features or better.

- (i) 6 Core outdoor armoured.
- (ii) Core Diameter 7.2 ± 0.5 mm with armoured Coating.
- (iii) Single Mode/ Multimode, as per requirement/ application.
- (iv) Standard Compliance - G.652
- (v) Meter marked
- (vi) Core Construction- Central Loose Tube
- (vii) Cable armouring – “High quality Electro Chromium Corrugated Steel Tape” Type
- (viii) Bandwidth at 1300 nm - In Gigabits
- (ix) It is the responsibility of the vendor to supply adequate length of cable to ensure proper networking at all locations

3) Media Converter

Media Converter must have following features or better

- (i) 1 No. 100/1000Base TX RJ-45 port
- (ii) 1 No. 1000Base-SX Single Mode Fiber SC type port
- (iii) 10Km distance support
- (iv) Auto-Negotiation Full or Half duplex on UTP port
- (v) Standard Compliance IEEE 802.3u 100Base TX, 1000BaseSX
- (vi) It is a responsibility of the vendor to specify and provide all required accessories to terminate, connect the lines at all locations wherever required
- (vii) 3 years on-site Warranty with 98 percent uptime commitment

4) Single Mode Fiber Optic Connector

Single Mode Fiber Optic Connector must have following features or better

TECHNICAL SPECIFICATIONS M&E

- (i) Suitable for the above mentioned Fiber Optic Cable Configuration
 - (ii) SC/ST/FC Connector, 9/125 micron
 - (iii) Phospore Bronze Construction/ Zirconia Sleeves
- 3 years on-site Warranty with 98 percent uptime commitment

5) Single Mode Fiber Optic Patch Chord

Single Mode Fiber Optic patch Chord must have following features or better.

- (i) Suitable for the mentioned Fiber Optic Cable/LIU Box Configuration
- (ii) Connectors - 4 Nos. attached
- (iii) SC-SC duplex type, 3 Meters
- (iv) Factory crimped with standard packaging
- (v) 3 years on-site Warranty with 98 percent uptime commitment

6) Light Interface Unit (LIU)

Light Interface Unit (LIU) must have following features or better

- (i) Suitable for the above mentioned Fiber Optic Switch/ Cable Configuration
 - (ii) Splicing tray suitable for atleast 6 Core required
 - (iii) Support for 6 to 12 core fiber with suitable connector plates and blank plates
 - (iv) Colour - Grey/Black
 - (v) Rack mountable
 - (vi) Should be fully loaded with couples
- 3 years on-site Warranty with 98 percent uptime commitment

7) 24 Port manageable Switch

Description: 24 port Fast Ethernet Managed Switch	
1	Interface: 24 x 10/100Base-Tx RJ-45 Ports, 2 x 10/100/1000Base-T & 2 x 100/1000Base- Combo SFP
2	Switching Capacity: 12.8Gbps

TECHNICAL SPECIFICATIONS M&E

3	Switching Type: Store & Forward
	64-byte Maximum Forwarding Rate: 9.5Mpps
	Packet Buffer: 4.1Mbits
	Flash memory: 16MB
	128MB SD RAM
	Features
	8K MAC Address table
	Auto MDI/MDIX crossover on all ports
	Auto-negotiation on every port
	IEEE 802.3x flow control
	9KB Jumbo frames support
	IPv6 Support: IPv4/v6 Dual Stack
	802.1D STP, 802.1w RSTP.
4	IGMP v1/v2 snooping, v3 awareness
	MLD v1, MLD v2 awareness
	802.3ad Link Aggregation
	Port Mirroring
	Loopback detection
	LLDP/LLDP-MED
	IP-MAC-Port Binding
	ARP Spoofing Prevention
	DHCP Server Screening
	802.1q VLAN,

TECHNICAL SPECIFICATIONS M&E

	<p>L2/L3/L4 ACL based on: 802.1p priority</p> <ul style="list-style-type: none"> • VLAN • MAC address • Ethernet type • IPv4 and IPv6 address • DSCP • Protocol type • TCP/UDP port number • IPv6 Traffic Class
	<p>Quality of Service (QoS)</p> <p>*802.1p, *Max. 8 queues per port, *Queue Handling: Strict, Weighted Round Robin (WRR). *Bandwidth control, *CoS Based on: 802.1p, DSCP, ToS, TCP/UDP port number, IPv6 traffic class</p>
5	Web-based GUI, Compact CLI though telnet, Telnet Server, SNMP v1/v2c/v3, log server, SSHv2, TFTP Client, SNTP, RMON v1.
6	Operating Temp: 0° to 50°C
7	MTBF: ≥330000 Hours
8	Certification: FCC Class A, CE Class A, VCCI Class A, IC, C-Tick, cUL, CE LVD

8) 24 Port patch Panel

24 Port patch Panel must have following features or better

- (i) Rack mountable patch panel
- (ii) CAT-6 performance
- (iii) Printed color coding to make termination easy
- (iv) ISO 11801 and EIA / TIA 568A standards
- (v) 3 years on-site Warranty with 98 percent uptime commitment

Characteristic	Min. Required Specification
Features	Be made of powder coated steel, in 24 port configurations.
	Allow for a minimum of 200 re-terminations without signal degradation below standards compliance limit.

TECHNICAL SPECIFICATIONS M&E

	Have port identification numbers on the front of the panel.
	Should have self adhesive, clear label holders (transparent plastic window type) and white designation labels with the panel, with optional color labels / icons.
	IDC: Suitable for 22-26 AWG stranded and solid wire compatible with both 110 & Krone punch down tools
	Improved cable management with optional cable management bar
	The Cat-6 transmission performance is in compliance with the ANSI/TIA/EIA 568C.2 standard
Mechanical Characteristics	Plastic Housing: ABS, UL94V-0 rated
	Operating Life: Minimum 750 insertion cycles
	Contact Material: Copper Alloy
	Contact Plating: 50µ" Gold plated on plug contact area
	Contact Force: 20N max (IEC 60603-7-4)
	Plug Retention Force: 15 lb.
IDC Connector	Plastic Housing: Polycarbonate, UL94V-0 rated or equivalent
	IDC cap: ABS, UL 94V -0
	Contact Material: Copper Alloy
	IDC Contact Plating: Phosphor bronze with tin plated
	Insertion Force: 20N max (IEC 60603-7-4)
	Wire Accommodation: 22-26 AWG solid

TECHNICAL SPECIFICATIONS M&E

9) 16 Port Switch

Description: 16 port 10/100 Unmanaged Switch	
1	Interface: 16 x 10/100 Base-Tx RJ-45 port
2	Switching capacity: 3.2 Gbps
3	Switching Type: Store & Forward
4	Features:
	8K MAC address Table
	Auto MDI/MDIX crossover on all ports
	Auto-negotiation on every port
	IEEE 802.3x flow control
	atleast 2,048 byte jumbo frames support
	IEEE 802.3az Energy-Efficient Ethernet (EEE)
5	Power Input: 230V AC or with suitable Power adapater
6	Operating Temp.: 0° to 40° C
7	Certifications: CE Class B, CE (LVD 2006/95/EC)

TECHNICAL SPECIFICATIONS M&E

10) 8 Port Switch

Description: 8 port 10/100 Unmanaged Switch	
1	Interface: 8 x 10/100 Base-Tx RJ-45 port
2	Switching capacity: 1.6 Gbps
3	Switching Type: Store & Forward
4	Features:
	2K MAC address Table
	Auto MDI/MDIX crossover on all ports
	Auto-negotiation on every port
	IEEE 802.3x flow control
	atleast 2,048 byte jumbo frames support
	IEEE 802.3az Energy-Efficient Ethernet (EEE)
5	Power Input: 230V AC or with suitable Power adapter
6	Operating Temp.: 0° to 40° C
7	Certifications: CE Class B, CE (LVD 2006/95/EC)

11) 3 / 7 Feet Patch Chord

3 / 7 Feet Patch Chord must have following features or better

- (i) Cat6 UTP 24AWG Patch cord
- (ii) Factory crimped and molded boots
- (iii) ISO/IEC 11801 & EIA/TIA 568A CAT-6 standards
- (iv) Jacks fitted with colored boots
- (v) Support upto 550 Mhz channel bandwidth
- (vi) UL listed / UL verified (certified)
- (viii) 24AWG

TECHNICAL SPECIFICATIONS M&E

12) 24 ports 10/100 with 2 combo ports PoE switch

Switch Hardware Specification
Switch with at least 24 X RJ-45 Gigabit Ethernet PoE Ports and 2 combo Ports.
Switching capacity should be 56Gbps or higher or non-blocking architecture.
Switch packet forwarding rate should be 41.7Mpps or higher or non-blocking architecture.
Switch MAC table should be at least 8K or higher.
Switch should be standard 19 inch 1U rack mountable.
Support for the Energy Efficient Ethernet (IEEE 802.3az) standard.
Switch should delivered 802.3at PoE+ and 802.3af PoE power to any of the RJ-45 ports.
The total power available for PoE switch should be 193W or higher.
Power input should be 100 to 240 VAC, 50/60 Hz, internal universal power supply.
Operating temperature should be -5 degree celsius to +50 degree celsius.
Certification: CE, FCC, BSMI, RoHS and cUL.
Switch Software Specification
Should support Head of Line blocking prevention for lower latency and better performance.
Support Jumbo Frame up to 10K Bytes or higher.
Should support IGMP Snooping, Able to create 250 or more IGMP groups and require support for IGMP Snooping Fast Leave,IGMP Snooping Querier
Should support MLD Snooping, Able to create 250 or more MLD groups, Per VLAN MLD Snooping and require support for MLD Snooping Fast Leave.
Should have 802.1D STP, 802.1w RSTP and 802.1s MSTP Spanning Tree Protocol.
Should support Spanning tree Root restriction
Should support Loopback detection (LBD) to detect the loop created by a specific port.

TECHNICAL SPECIFICATIONS M&E

Should support Multicast Filtering to filters or forward all unregistered groups.

Switch should support IEEE 802.1Q VLAN tagging for Ethernet frames.

Different type of VLAN like Port based, Auto Surveillance, Auto Voice, Asymmetric Vlan etc. should be available for configuration.

Switch should support QoS (quality of service) IEEE 802.1P for traffic prioritization. It should support 8 queues per port.

Different type of QoS priority like Strict Priority Queue and Weighted Round Robin.

Port based ingress / egress rate limit function should be available with limit in increments as low as 16 Kbps.

Switch should support Neighbor Discovery (ND) protocol for IPv6.

Switch should support to create atleast 4 IP interface

Should support default routing and static routing with minimum 100 IPv4 static route entries and minimum 50 IPv6 static route entries.

Support at least 700 access control entries. Each entry should be applied on single / multiple ports with permit / deny action.

Should support port security to secures the access port based on MAC address.

Should have broadcast, multicast, and unicast storm control to prevents faulty end stations from degrading overall systems performance.

Support Traffic Segmentation to restricted traffic flow from a single or group of ports, to a another group of ports.

Should have SSH and SSL for IPv4 and IPv6.

Require prevention of DoS attacks, which include Land, Blat, TCP Null Scan, TCP Xmas Scan and TCP SYNFIN.

Should support 802.1X port based authentication.

Should support ARP spoofing prevention.

Should support DHCP snooping and DHCP server screening.

Switch should able to create a binding table for IP + MAC + Port to prevents a malicious user from spoofing or to restrict the unauthorized users.

TECHNICAL SPECIFICATIONS M&E

Should support 802.1X RADIUS and local server database authentication.

Should have option to check the status of copper cables using the cable-diagnostics time domain reflectometer (TDR).

Able to manage through Web-GUI, Compact CLI and Telnet.

Should support SNMP v1, v2c, v3 and SNMP Traps and Remote Monitoring (RMON).

Should have dual Image support to reduced down time for the switches.

Switch should support dynamic host configuration protocol (DHCP) auto configuration of multiple switches through a boot server eases switch deployment.

Should have SNTP/NTP protocol for time synchronization.

Switch should be IPv6 Ready Compliance.

Should support Link Layer Discovery Protocol (LLDP) and LLDP-MED.

Note

Switch should be supplied with the all necessary components like Power cord, Rack-mount bracket, Installation Guide, etc. and necessary software image file to fulfil all above mention feature set from day 1.

13) Single Mode 1G SFP - 10KM Module

Transceiver should be Enhanced Small Form-Pluggable (SFP) form factor and compatible with quoted switches.

Transceiver should be Hot pluggable and support 1G speed on Single Mode 9/125 um fiber.

Should be RoHS Compliant

Should be Multi-Source Agreement (MSA) specification compliant.

Transceiver should be compliant with IEEE802.3z standards.

Transceiver distance capacity should be 10Km.

Transceiver interface should be Duplex LC connector.

Operating Temperature: 0 to 50 °C

TECHNICAL SPECIFICATIONS M&E

14) 1G Media Convertor for Single Mode

Feature set for Media Convertor
One RJ - 45 port and one Fiber port with duplex SC type connector.
1000BASE-TX Ethernet twisted pair signals to 1000BASE-FX Giga Ethernet fiber signals.
Minimum fiber cable distance for single-mode distance should be 10Kms.
Should support store and forward traffic forwarding.
IEEE802.3u/x/ab 1000BASE-TX, 100BASE- LX (Giga Ethernet, 1000Mbps)
LED's should be provided for detecting the Fiber Link and detecting the Ethernet Link.
Fiber port should support 9/125um Single Mode Fiber with Wavelength 1310 nm.
Compatible Power adapter should be supplied with media convertor.
Operating Temperature: 0 to 50 °C
Shall have CE,FCC, ROHS certified.

15) 8 port 10/100 with 2 combo ports PoE switch

Switch Hardware Specification
Switch with at least 8 X RJ-45 Gigabit Ethernet PoE Ports and additional 2 X SFP 1G Ports.
Switching capacity should be 20Gbps or higher or non-blocking architecture.
Switch packet forwarding rate should be 14Mpps or higher or non-blocking architecture.
Switch MAC table should be at least 8K or higher.
Switch should be standard 19 inch 1U rack mountable.
Support for the Energy Efficient Ethernet (IEEE 802.3az) standard.
Switch should delivered 802.3at PoE+ and 802.3af PoE power to any of the RJ-45 ports.
The total power available for PoE switch should be 130W or higher.

TECHNICAL SPECIFICATIONS M&E

Power input should be 100 to 240 VAC, 50/60 Hz, internal universal power supply.

Operating temperature should be -5 degree celsius to +50 degree celsius.

Certification: CE, FCC, BSMI, RoHS and cUL.

Switch Software Specification

Should support Head of Line blocking prevention for lower latency and better performance.

Support Jumbo Frame up to 10K Bytes or higher.

Should support IGMP Snooping, Able to create 250 or more IGMP groups and require support for IGMP Snooping Fast Leave,IGMP Snooping Querier

Should support MLD Snooping, Able to create 250 or more MLD groups, Per VLAN MLD Snooping and require support for MLD Snooping Fast Leave.

Should have 802.1D STP, 802.1w RSTP and 802.1s MSTP Spanning Tree Protocol.

Should support Spanning tree Root restriction

Should support Loopback detection (LBD) to detect the loop created by a specific port.

Should support Multicast Filtering to filters or forward all unregistered groups.

Switch should support IEEE 802.1Q VLAN tagging for Ethernet frames.

Different type of VLAN like Port based, Auto Surveillance, Auto Voice, Asymmetric Vlan etc. should be available for configuration.

Switch should support QoS (quality of service) IEEE 802.1P for traffic prioritization. It should support 8 queues per port.

Different type of QoS priority like Strict Priority Queue and Weighted Round Robin.

Port based ingress / egress rate limit function should be available with limit in increments as low as 16 Kbps.

Switch should support Neighbor Discovery (ND) protocol for IPv6.

Switch should support to create atleast 4 IP interface

Should support default routing and static routing with minimum 100 IPv4 static route entries and minimum 50 IPv6 static route entries.

TECHNICAL SPECIFICATIONS M&E

Support at least 700 access control entries. Each entry should be applied on single / multiple ports with permit / deny action.

Should support port security to secures the access port based on MAC address.

should have broadcast, multicast, and unicast storm control to prevents faulty end stations from degrading overall systems performance.

Support Traffic Segmentation to restricted traffic flow from a single or group of ports, to a another group of ports.

Should have SSH and SSL for IPv4 and IPv6.

Require prevention of DoS attacks, which include Land, Blat, TCP Null Scan, TCP Xmas Scan and TCP SYNFIN.

Should support 802.1X port based authentication.

Should support ARP spoofing prevention.

Should support DHCP snooping and DHCP server screening.

Switch should able to create a binding table for IP + MAC + Port to prevents a malicious user from spoofing or to restrict the unauthorized users.

Should support 802.1X RADIUS and local server database authentication.

Should have option to check the status of copper cables using the cable-diagnostics time domain reflectometer (TDR).

Able to manage trough Web-GUI, Compact CLI and Telnet.

Should support SNMP v1, v2c, v3 and SNMP Traps and Remote Monitoring (RMON).

Should have dual Image support to reduced down time for the switches.

Switch should support dynamic host configuration protocol (DHCP) auto configuration of multiple switches through a boot server eases switch deployment.

Should have SNTP/NTP protocol for time synchronization.

Switch should be IPv6 Ready Compliance.

Should support Link Layer Discovery Protocol (LLDP) and LLDP-MED.

TECHNICAL SPECIFICATIONS M&E

Note
Switch should be supplied with the all necessary components like Power cord, Rack-mount bracket, Installation Guide, etc. and necessary software image file to fulfil all above mention feature set from day 1.

16) 12 core single mode fibre optic armoured cable

Characteristic	Min. Required Specification	
GENERAL:	The 12 core armored fiber cable type is a Matched Cladding Single Mode	
	Fiber dual coated with acrylate coating.	
	The fiber is optimized for operation at 1310 nm and at 1550 nm.	
	Should fulfill the requirements of: IEC 793-2: 1992, EN 188101 ITU-T Recommendation G.652	
	Testing methods are in accordance with the following standards: ITU-T G.652.D IEC 793-1 EN 188 000	
GEOMETRICAL PROPERTIES:	Nominal mode field diameter	9.2 μm
	Mode field diameter tolerance	$\pm 4\%$
	Cladding diameter	125 μm
	Cladding diameter tolerance	$\pm 1 \mu\text{m}$

TECHNICAL SPECIFICATIONS M&E

Characteristic	Min. Required Specification	
	Mode field concentricity error	$< 1 \mu\text{m}$
	Cladding non-circularity	$< 2 \%$
MATERIALS	CORE	Germanium doped core with no phosphorus i.e. reduced tendency for hydrogen degradation.
	COATING	UV-curable dual layer acrylate coating, which ensures excellent micro bending and abrasion resistance.
	Stripping force after conditioning at $23 \pm 5 \text{ }^\circ\text{C}$ at 40 - 60 % RH for 24 h.	
	Min.	1.0 N
	Max.	3.5 N
	Stripping force after ageing in water at $70 \pm 5 \text{ }^\circ\text{C}$ for 168 h.	
	Min.	1.0 N
	Max.	3.5 N
OPTICAL PROPERTIES	Attenuation (of cable with fibers):	
	At 1310 nm	$\leq 0.36 \text{ dB/km}$
	In the range 1285-1330 nm	$\leq 0.40 \text{ dB/km}$
	At 1550 nm	$\leq 0.22 \text{ dB/km}$
	Cut-off wavelength λ_c :	
	High limit	1330 nm
	Low limit	1180 nm
	Cut-off wavelength λ_{cc}	

TECHNICAL SPECIFICATIONS M&E

Characteristic	Min. Required Specification	
	High limit	1260 nm
	Loss increase at 1550 nm for 100 turns of fiber loosely wound with a 37.5 mm radius:	
	Max.	0.1 dB
	Dispersion:	
	Zero dispersion wavelength	1310 nm
	Tolerance of zero dispersion	
	Wavelength	-10/+12 nm
	Zero-dispersion slope:	
	Max.	0.092 ps/(nm ² • □km)
	Chromatic dispersion coefficient:	
	In 1285 nm - 1330 nm interval:	
	Max.	3.5ps/km • □nm
	In 1270 nm - 1340 nm interval	
	Max.	6 ps/km □ • nm
	At 1550 nm	
	Max.	18 ps/km • □nm
	Polarisation Mode Dispersion (PMD):	
	Max.	<=0.2 ps/km

TECHNICAL SPECIFICATIONS M&E

Characteristic	Min. Required Specification	
	In homogeneity of OTDR trace for any two 1000 meter fiber lengths	
	Max.	0.1 dB/km
	Proof test level	%

17) 12 port LIU Fully Loaded

Characteristic	Min. Required Specification
	Fully loaded LIU have sufficient slots accommodate Simplex/duplex SC adapters.
	Aluminum base material for light mounting
	Should have Splice Tray & Cable Spool provision inside
	Can manage both splices and terminations
	Accessory kit consists of cable ties, mounting ear screw earthing and spiral wrap tube.
	Panel cover should be slide out for easy maintenance
	Front-Mounted Cable Saddles for jumper management
	Can Include adapter panel for maximum 12 simplex SC or 6 duplex SC Terminations
	Removable rubber grommet allows for pre-terminated fiber trunk installation, protect cable and minimize dust build-up
	Removable Rear & Front cover for better access to interior of LIU

18) ADAPTORS: - SC Type

Characteristic	Min. Required Specification
Features	All SC adaptors should be Simplex and duplex type. Adaptors should have compact design & high precision, which perform well under various circumstances &

TECHNICAL SPECIFICATIONS M&E

	maintain good plug retention strength.
	Telcordia, TIA/EIA, IEC compliance
Insertion Loss	0.20db for Zirconia Sleeve
Sleeve/Ferrule Withdrawal Force	SC Adapter 2.0N ~ 5.9N, LC Adapter-1.0N ~ 2.5N

19) Optical Fiber Pigtail – SC Type

Characteristic	Min. Required Specification
Features	Provide a field installable single mode SC pigtails to terminate fiber optic cables from cable-to-cable, cable-to-equipment and equipment-to-equipment.
	The connector must: Be field installable
	Utilize a UPC polishing on the tip to provide high yield during installation.
	Meet EIA and IEC standards for repeatability.
Insertion Loss	<0.3 db Max.
Mating Cycle	1000 Times
Return Loss	> 50 db
Connector ferrule	Ceramic
Operating Temp.	-40 deg C. to +85 deg.c
Standard	EIA/TIA 568.C-2
Types	SC Type Simplex

TECHNICAL SPECIFICATIONS M&E

20) Optical Fiber Equipment Cords (minimum 3 meter)

Characteristic	Min. Required Specification
Features	Optical fiber patch leads shall comprise of Single mode 9/125µm fiber with SC-SC, fiber connectors terminated at each end. The optical fiber patch leads shall comply with the following specifications:
	Optical Fiber – Corning Single Mode
	Connector: Zirconia ceramic ferrule
	Pre-radiuses and pre-polished ferrule
	Duplex Type
	Color-coded Yellow for SM
	Insertion Loss - <0.2 db
	Cable: 9/125, SM
	Repeatability - < 0.2 db
	Durability – 1000 mating cycle
	Working Temp: -40 deg. C to + 85 deg. C
	Standard: G652D, G 657A & G 657B

21) 9U rack specs:-

Wall Mount 9U x 550 W x 450 D ,
Front Glass Door (tinted, Toughened) with Lock & Key,
2 pairs of 19" Mounting Rails with U-Marking
Welded Side Walls With Metal Engraved D-Link Logo

Standard Accessories :

1U Cable Manager (1), Hardware Packet (1 Pkt)
6 Socket 5 Amp. Power Distribution Unit (1 No)
Roof Mounted Fan Unit / 90 CFM /230V AC (1 No)

TECHNICAL SPECIFICATIONS M&E

22) 22U rack specs:-

22U Network Enclosure Frame-600X800-STEEL	Nos	1
Casters Set of 4	Nos	1
Adjustable Levellers set of 4	Nos	1
Glass Door-600-22U	Nos	1
Metal Door-600-22U-Vented	Nos	1
Side Panels-800-22U-Vented	Nos	2
Mounting Hardware-(Pack of 20)	set	1
FHU with 2 FAN 180CFM	Nos	1
Horizontal Power Distribution Unit with 6 x 5/15A sockets Round Pin, 230 Volts AC, 32 Amp with Plug	Nos	1
Horz. Cable Manager-1U-Loop	Nos	1

23) 32U rack specs:-

32U Network Enclosure Frame-600X800-STEEL	Nos	1
Casters Set of 4	Nos	1
Adjustable Levellers set of 4	Nos	1
Glass Door-600-32U	Nos	1
Metal Door-600-32U-Vented	Nos	1
Side Panels-800-32U-Vented	Nos	2
Mounting Hardware-(Pack of 20)	set	1
FHU with 2 FAN 180CFM	Nos	1
Vertical Power Distribution Unit with 12 x 5/15 sockets Round Pin, 230 Volts AC, 32 Amp with Plug	Nos	1
Horz. Cable Manager-1U-Loop	Nos	1

TECHNICAL SPECIFICATIONS M&E

24) Access Control System Controller

Sr. No.	Requirement		Compliance
1	Type	:	Microprocessor based
2	Memory	:	Non volatile
3	No. of door controlled	:	1 Door ; Quantity - As per requirement
		:	2 Doors ; Quantity - As per requirement
4	No. of transaction storage	:	99,999 (Minimum)
5	Analog input & Relay output count	:	IN: Min 7 nos. & OUT: 4 nos.
6	Interface format	:	Wiegand Standard : (up to 128-bit data)/ RS 485/ RS 232/ RJ 45/ USB/ UART/
7	IP Rating for enclosure	:	Indoor use: IP54; Outdoor use: IP65
8	Operating humidity	:	0 to 95%, non condensing
9	Operating temperature	:	0 to 50 degree C
10	Mounting	:	Wall mounting in CRCA enclosure with 2mm thickness
11	Power Supply	:	12 or 24 VDC
12	Operating current	:	1000mA @12-24VDC
13	Quantity	:	As per requirement

TECHNICAL SPECIFICATIONS M&E

(ix) Smart/ Proximity Access card reader

Card Type	:	Contactless Card
Technology	:	As required
Card read range	:	10 cm (minimum)
Transaction time	:	<100 msec
Memory Type	:	EEPROM
Printable card surface	:	Required
Write endurance	:	1,00,000 cycles (Minimum)
Data retention	:	10 years (Minimum)
Applications	:	Access Control/ Time and Attendance
Compliance required on standards	:	ISO14443 & ISO15693
Operating humidity	:	0 to 95%, non condensing
Operating temperature	:	to 50 degree C



Network Accessories

TECHNICAL SPECIFICATIONS M&E

SP-ME-TS-56 Inverter:

Scope of work includes supply, installation, testing and commissioning of digital sign wave inverter with necessary safety etc.

Equipment shall be manufactured as per standard manufacturer's specification. The unit shall be housed in powder coated 1.2 mm CRCA sheet enclosure with following fault protection on mains/inverter mode-

Under voltage on mains mode

Over voltage on mains mode

Charger protection on mains mode

Overload on inverter mode

Short circuit on inverter mode

Low battery on inverter mode

Battery reverse on inverter mode

Under voltage on inverter mode

Over voltage on inverter mode

Under voltage on inverter mode

LED display fro above fault protection

Alarm for above fault protection

Arrangement to cut of neutral of supplier when supply from inverter is on

Additional specification-

Minimum efficiency-	85%
Voltage inverter mode-	230V nominal +/- 12%
Frequency inverter mode-	50Hz +/- 2%
Overload-	>110% for 10 mintes
Transfer time-	30mS
Switching device	IGBT based
Harmonic distortion	<5%
Over load/ short circuit/charger	
Protection-	through MCB
Battery type-	12V DC, Tubular
Wiring of 5 meters	



TECHNICAL SPECIFICATIONS M&E

SP-ME-TS-57 ELECTRONIC SIREN

Scope of work includes supply, installation, testing and commissioning of Electronic siren, horizontal mounting suitable for 230V/415V AC supply.

Weather shade:

Weather shade shall be provided for protection of Siren motor with louvers from all sides for ventilation and clear sounding of siren duly painted with one coat of red oxide paint and two coat of approved enamel paint.

Shade shall be fabricated from 18swg MS sheet with necessary cutting, bending and welding. Shade shall be provided with high density, heavy duty class rubber anti vibrating pads with nut, bolts.

Siren motor:

Supply and installation of siren motor of specified HP, single/three phase AC, 50Hz, 230V/415V type as per IS 1941 (part I) at the rated speed of not less than 6000rpm within 10sec of start for the range upto 3.5km.

The stator and rotor shall be of aluminium alloy. The siren motor shall be compact in design and reliable in operation and stable for installation in open as well as in exposed position in any climate condition. The motor with class F insulation shall be totally enclosed with greased sealed ball bearing and shall conform to IS 325. If housing is provided for protection, it shall not affect the sound output at the specified distance. The motor shall be fitted with two blowers (double mounted) horizontally, properly balanced and mounted on opposite side of motor shaft.

The siren motor complete assembly shall be erected on designated plate on provided cement concrete foundation with anti vibration pads, nut, bolts etc.



TECHNICAL SPECIFICATIONS M&E

SP-ME-TS-58 PRESSURE GAUGE

Pressure gauges shall comply with IS 3624/ BS 1780. The parts of pressure gauge shall be Stainless Steel.

The Minimum diameter for round pressure gauges shall be 100 mm unless specified otherwise or where the gauge forms part of a standard item of equipment.

The zero and span of pressure gauge shall not change more than $\pm 0.1\%$ of the span per $^{\circ}\text{C}$ changes in ambient temperature



TECHNICAL SPECIFICATIONS M&E

SP-ME-TS-59 GUN METAL VALVE

The Gun Metal Valve shall be manufactured in accordance with IS 778/ BS 5154. The Valve shall be Class 1 suitable for non-shock cold working pressure upto 1.0 Mpa (cold service means a temperature not exceeding 45°C). The valve shall have flanged ends or screwed end, integral body seat.

Body: The Body shall be made of brass DCB2 of IS: 1264 or Leaded Tin Bronze LTB2 of IS: 318.

Bonnet: The material of bonnet shall be brass DCB2 of IS: 1264 or Leaded Tin Bronze LTB2 of IS: 318 or forged brass IS: 3488.

Back Seat: The gate valve shall permit 'on-line' replacement of the gland packing under maximum cold working pressure without showing any sign of leakage through the stuffing box when valve is on full on position.

Stem: The stem shall be in one piece and shall be designed to prevent the wedge or disc from leaving the stem. The total length shall be such that the handwheel is freely gripped by the hand when the valve is closed and also repacking of gland is possible without taking of the hand wheel when the valve is full open.

Wedge: The wedge in the wedge type gate valve shall be adequately guided in the body so that the seating surfaces of the wedge do not touch those of the body until near the point of closure.

Disc in Check Valve: Disc shall be provided with renewable synthetic rubber seating ring.

Body seat: The seat may be integral with the body or may be separate renewable rings screwed-in to the body or shall have lug or slots to facilitate renewal. Seat ring faces shall be finished smooth and edges shall be deburred.

Handwheel: Handwheel shall close the valve by turning in clockwise direction when facing the wheel. Hand wheel shall be marked with the word 'open' or 'close' with arrow to indicate direction of opening or closing.



TECHNICAL SPECIFICATIONS M&E

SP-ME-TS-60 APC SYSTEM FOR CONVENTIONAL WOOD PYRE

1) HOOD

The hood shall be made of SS 410 sheet of 2 mm thickness. The opening base dimensions will be 4 mtrs. x 2 mtrs. Height of hood from opening base, extended Trapezoid centrally (discharge type) shall be up to 1 Meter. Central discharge out let shall be 600 mm x 600mm. and connected to 600 mm Dia SS 304 Duct.. It shall be fixed at the height of about 2.15 mtrs from ground level and located centrally above pyres. It shall be properly supported from above by adequate size of M.S. beam / angle / brackets/channels taking support of existing beams or by providing separate MS supports from above. Suitable size wire mesh made from SS 410 rods and of suitable gauge shall be provided to restrict the birds/solid particles' entry inside duct system.

2) DUCT

The duct shall be made of SS 304 with 2 mm thickness and 600 mm Dia. and same shall be connected in between each hood outlet, Cyclonic water scrubber, blower and chimney including by-pass arrangement of scrubber. Each piece of the duct shall not be more than 2.5 metre long. Flanges shall be used at each joints of ducting/Bends/reducers etc. Flange shall be approximately 6 mm thick x 40 mm wide. Asbestos graphite packing of suitable thickness shall be used between two flanges to avoid leakages. The flanges shall be fixed with SS nut bolts and washer of suitable size. Ducting shall be properly supported at a suitable height by means of M.S. angle / M.S. Channels and M.S. brackets taking advantage of M.S. Beams/Channels of existing shed and providing suitable vertical supports as per requirement

3) DAMPER

The damper assembly shall be fabricated from S.S. 304, 3 mm thick ,gear operated (not spring loaded) and chain to operate it. There shall be manually operated butterfly type damper provided with S.S.304 chain for smooth operation of damper gate.

4) CYCLONIC SCRUBBER

The Cyclonic Water Scrubber shall be designed and fabricated from SS 304 grade stainless steel plate. The bottom and top cone shall be fabricated from 5 mm thick plate and the shell shall be fabricated from 4 mm thick plate. The spray nozzles/full cone of approved quality shall be provided in the scrubber for scrubbing the flue gases. The Scrubber shall be efficient & capable of scrubbing particulate contaminants having average size of 10 microns and shall limit upto concentration of 150 mg/Nm3.. The nozzles shall be installed in such a way that it should clean complete quantum of smoke as well as all sides of scrubber so that there is no formation of carbon lumps. At bottom, the water seal arrangement shall be provided with proper design. A sump tank of capacity 2 cu. mtr. approx. shall be installed with foundation below the scrubber to collect drain water. It shall be fabricated from Mild steel of plate of 5 mm thick and internally painted with chlorinated rubber paint. Baffle shall be provided to separate solid particles from water. 2 HP 3 phase water pump for nozzles having required discharge pressure complete with C class GI plumbing and ISI mark valves etc. should be provided. The scrubber shall be installed with the help of M.S. channels of

TECHNICAL SPECIFICATIONS M&E

suitable size grouted in cement concrete foundation in approved manner. Scrubber shall have Provision for controlling the foul odour of cremation or the gases like SO_x , NO_x etc

5) BLOWER

The capacity of blower will be approx. 18000 CuM Per hour at 300 mm to 350mm WG pressure. The impeller and casing shall be fabricated from SS 304 material. The blower shall be coupled with 40 HP three phase 440 volts 50 Hz T.E.F.C. squirrel cage induction motor as per ISI specification .The blower set shall be provided with Silencer and anti vibration absorbers to reduce noise level. The blower's casing shall be provided with inspection cover of suitable size & separate drain plug at bottom to remove moisture entrapped.

6) CHIMNEY

The chimney shall be a self-supported type, in total five pieces, Total length of the chimney shall be 30.5 meters. The chimney shall be fabricated in accordance with IS 6533: 1989 part II & the material of the chimney shall be mild steel plate conforming to IS 2062.

All the structural steel components will conform to IS 2062 & contractor shall provide test reports for the same. The shells shall be fabricated out of 10 mm MS plate, 8 mm MS plate and 6-mm MS plate

The chimney shall be provided with lightening arrestor of copper electrode with proper copper earthing strip of size 25 x 3 mm. and earthing station with a copper plate, electrode. A suitable canopy made up of S. S. 304 material shall be provided at the top of the chimney, so as to protect the chimney from rainwater.

The foundation shall be done as per the detail report obtained by soil testing. The earth pit of appropriate size shall be excavated for foundation of chimney. Construction of the cement concrete foundation shall be designed to withstand wind pressure. Suitable Nos. of high tensile foundation nut and bolts shall be provided to the base plate and gusset plate equi-spaced and epoxy coated embedded in M-250 quality with 1:1:2 ratio cement concrete foundation. Base plate of 32-mm. thick and 1800 x 1800 mm. shall be provided in RCC foundation with extended 4 Nos. of foundation bolts, to suit site condition. Above 500 mm. of this plate, circular base plate of 1800 mm. dia with adequate Nos. of foundation bolts of 32 mm dia. and of adequate length as suggested by Structural Engineer to suit site condition. Base gussets of 10-mm. thick plates shall join both the plates. Adequate nos. of gussets plates or as per suggestion of Site Engineer shall be provided to suit site conditions. Nuts and Bolts for the foundation bolts shall be made by EN-8 steel.

Operation and Maintenance of APC system

Scope of Work:

The work comprises of the following:

Operating the Air Pollution Control Equipments round the clock (Day & Night) for 365 days a year without break or holidays in an approved manner by deploying sufficient manpower.

TECHNICAL SPECIFICATIONS M&E

The comprehensive maintenance of APC Equipments on daily, weekly, monthly, quarterly & annual basis will be done as per Schedule I, II & III. The scheme also envisages replacement of consumables like caustic soda, gear oil, lubricants, cotton wastes, hardware, nut bolts & bearings, etc. and other items required for successful running of APC Equipments like control panel equipments viz. relays, contactors, switches, indicating lamps, wires, cables, timers, etc. except blower impeller & shaft.

I- Operation: -

- (i) The contractor shall utilize the services of trained, skilled personnel who will be directly employed and appointed by the contractors. They shall be qualified and experienced to keep the entire APCE system in proper working condition. They will also take all responsible care to maintain the equipment in efficient, reliable, neat, tidy and safe operational condition.
- (ii) The contractor shall give service and maintenance programme for every month in advance. The contractor shall direct their personnel as per schedule programme given and approved by user department to the above said equipment once in a month during working hour to examine, lubricate and adjust the equipment.
- (iii) The contractor shall attend to any number of breakdown calls on all days including Sundays and Holidays and in case of Emergency during night hours under unavoidable circumstances.
- (iv) The contractor shall maintain the record of all the repairs, servicing and maintenance carried out and shall submit the copy of it to the concern office
- (v) The contractor shall attend the complaints free of cost whenever called by the Corporation.
- (vi) Whenever found necessary, the contractor shall replace the spares and other parts of all equipments integrated to the APC Equipment operation, safety and statutory requirement free of cost.
- (vii) The staff posted for operation and maintenance shall wear uniform, which shall be got approved from MCGM authority before use. They shall always wear Identity card prepared by the contractor and signed by MCGM authority.
- (viii) The persons/employees deployed for operation and maintenance shall be covered as per Contract Labour (Regulation & abolition) Act 1970 and registered with the Labour Commissioner.
- (ix) The plant including water scrubber, blower, and motor etc shall be maintained for preventive maintenance as per the schedule i.e. daily, weekly, monthly, six monthly and yearly.
- (x) The contractor shall have to provide safety equipments to its personnel and they will also be adequately insured.

II-Maintenance: -

- a) Daily maintenance:- Clean the A.P.C.E. & maintain cleanliness of the surrounding area.

TECHNICAL SPECIFICATIONS M&E

b) Weekly maintenance:- The contractor shall clean, grease, tighten the nut bolts and clean the scrubber nozzles, drainage line, etc.

c) Monthly maintenance: Contractor shall open the blower and scrubber and control panel, and Clean to remove dust particles, Also grease all moving parts & reassemble the equipments.

d)Quarterly maintenance:-

(a) Servicing of Scrubber- The Contractor shall dismantle the Scrubber i.e. Remove, clean, refix and align the nozzles. Non working nozzles shall be replaced.

The overall cleaning of the scrubber shall be done.

(b) Servicing of blower- The Contractor shall dismantle the blower assembly, clean the impeller and dynamically balance. The belt tension and pulley shall be checked and align properly. All the fasteners shall be tightened and replaced if necessary.

c) Servicing of control Panel – The control Panel shall be cleaned and checked. The electrical contact shall be sprayed with CRC. The nonworking parts and meters shall be replaced.

(d) Earth Pit :- The Earth Pit shall be cleaned and checked and watered to maintain the required earth resistance within the prescribed limits.

e) Six monthly maintenance:- The Contractor shall dismantle the blower & scrubber to clean and remove the foreign particles and readjust and assemble the unit.

f) Yearly maintenance: -

a)The contractor shall overhaul and service the scrubber, blower, and other plant & machinery as per direction of Engineer.

b)The painting of APC equipments like blower motors, Chimney, Sump tanks & APC equipments shed shall be done as per direction of engineer.

c)The scrubber efficiency test / Emission test shall be carried out by Approved MPCB / CPCB laboratory as per norms and test certificates shall be submitted & also Ultrasonic test for chimney shall taken as per norms and test certificates shall be submitted, the cost is inclusive no extra charges will be paid.

d)The painting work of chimney includes removing of mill scales & rust with suitable mechanical tool / scrubber & wire-brushing and chipping to remove loose rust & scale. The heat-resistant paint withstanding temp. upto 250o C manufactured by Shalimar Paints Ltd. i.e. Tuffcote HT 600 or Berger Paints. Three coats shall be applied so as to have a uniform thickness & have aesthetic look. Sufficient time i.e. minimum 24 hrs. shall be allowed between successive coating.

e)The successful contractor shall paint sump tank of 2000 Ltr. capacity with chlorinated rubber paints after awarding the contract within three months period and get it inspected by Municipal engineer.

f)The contractor shall note that all fast consumable spares & material like caustic soda shall be kept with them in stock and replace whenever required. The same shall be

TECHNICAL SPECIFICATIONS M&E

included along with the cost of spare in the offer. The tenderer shall submit their offer inclusive of all spares/parts required for comprehensive maintenances of plant & machineries necessary for smooth & trouble free operation.

g)The successful tenderer shall carry out the Emission Test (Stack gas analysis) and scrubber efficiency test from the authorized laboratories approved / recognized by MPCB/CPCB/Ministry of Environment once every year. The emission result shall prominently display the concentration of total particulate matter in flue gas at entry & outlet of the scrubber. The concentration of various gases viz. Hcl, Hf, SO₂, CO₂, NO₂, CO, Lead, Mercury, etc. shall be documented and the same shall be within the permissible value otherwise necessary corrective action shall be taken by the contractor without any extra cost.

h)The performance of the contractor shall be reviewed after completion of every six months, & if not found satisfactory, the MCGM reserves the right to terminate the contract with one month's notice. It is also essential on the part of tenderer to inspect the site before submitting the offer and no claim shall be entertained on account of ignorance later.

3) Penalty:-

Annual Servicing & Comprehensive Maintenance:-

(i)If the APC equipment remains under breakdown for more than 48 hours, no Operational charges & Maint. Charges will be paid for the break down period. In addition a penalty of Rs.1000/-per day will be levied after 48 hours of break down for not attending the breakdown.

(ii) The contractors personnel's shall operate the plant day and night (round the clock for 365 days a year) as & when necessary. If contractor fails to provide the staff round the clock, a penalty of Rs.1000/-per shift will be levied without any reference.

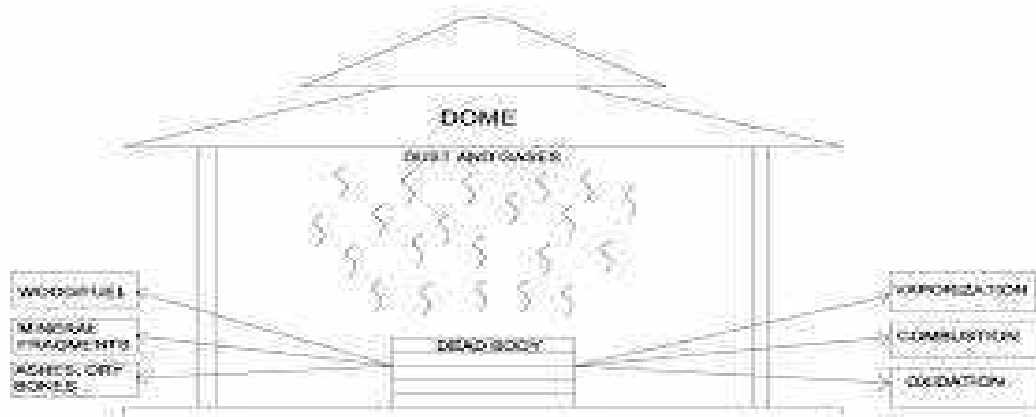

TECHNICAL SPECIFICATIONS M&E

SP-ME-TS-61 Conventional Wood Pyre System

The work of casting, Grinding, drilling & Supply of C.I. Pyre set -

1. Pyre set of C.I. Grade (FG200), IS-210 duly machined with drilled holes, including grinding, chipping operations.
2. Slot size in side panel should be more than 160 X 75 mm (As Per Site Requirement).
3. Aluminum pattern for casting shall be arranged by successful contractor so that casting of good finish can be obtained.
4. The C.I. Casting, Grade (FG 200), IS-210 pyre sets shall be free from crack & any surface defects.
5. Casting of pyre set should be free from all type of casting defects such as swelling, hard spots, blow holes, shrinking, porosity, crushes etc.
6. The weight of finished pyre set should be 800 Kg. with permissible deviation (+/- 1%)
7. For assembly of pyre set nut bolt of size ½ inch. Dia. X 3 inch long with nut & washer (56 Nos Approx) S.S. 304 grade material shall be supplied.
8. For foundation of pyre set foundation bolts of size ½ inch. Dia. X 3 inch long with nut & washer (16 sets) shall be supplied.

Construction of pyre set (5 nos.) foundation :-

- a) The S.S. 304 foundation bolts of size ½ inc. Dia. x 18 inch long with nut & washer (16 set) shall be grouted for each pyre
- b) Total 6 Nos. of Concrete Blocks with Foundation Bolts set in them shall be made and cured, Concrete blocks will be set as per CI Pyre template. Fire Bricks shall be placed in the space between the blocks. Thus forming the Fire Resistant Supports.
- c) The fire bricks having size 9" x 4.5" x 3" as per IS – 8 standard shall be supplied & pyre sets shall be installed using good quality fire bricks & mixture of Thermotex cement & ACC fire clay with water in right proportions.
- d) The new fire resistant supports (2 nos. per pyre sets) shall be constructed using best quality fire bricks as per IS – 8 bonded by the mixture of Thermotex cement & plastering with fire clay supercrete cement, The R.C.C. foundation shall be constructed using templates, shuttering clips, supports etc., in an approved manner. The foundation shall be cured using wet gunny bags for at least 7 days to ensure normal curing.
- e) Following the curing, the C.I. Pyre set components shall be assembled & joint together with S.S. 304 nut bolts & washers of size ½ inc. Dia. x 3 inch/ 4 inch long (56 Nos) in an approved manner. The pyre set duly assembled in position shall be held by the 16 nos. of foundation bolts already grouted in the RCC foundation. Also after wards these nut bolt fixtures throughout the assembly shall further be locked permanently by welding them thoroughly followed by removing of any carbon base deposition.
- f) The ash chambers shall be constructed at the bottom of each pyre set as per existing size.
- g) The damaged floor space area around the pyre set shall be re-plastered with ordinary port land cement of suitable grade as per site condition & instruction of site engineer.

TECHNICAL SPECIFICATIONS M&E

SP-ME-TS-62 : PNG BASED FURNACE SYSTEM

Hindu Cemeteries of MCGM are to be equipped with PNG Based Furnace system. Currently these cemeteries cremate numbers of dead bodies which varies in the weight & condition of the corpse as far as bones to fats ratio is concerned. Usually the dead bodies received for cremation are with normal body-fat content. However sometimes the corpse received are decomposed (majority of which are received from mortuary, unclaimed bodies etc.) & sometimes deceased (having low fats).

TECHNICAL SPECIFICATIONS OF PNG GAS FIRED CREMATOR

These specifications cover, construction of RCC structure for chimney foundation, design, fabrication supply, installation and testing commissioning of PNG fired cremation furnace, complete with suitable body charging trolley, removing last remains, conveniently, fresh air supply and exhaust air systems, flue ducts, water scrubber, chimney etc., to suit the site conditions.

Salient Features of Furnace

- Primary as well as secondary combustion zones.
- Preheated combustion air for primary and secondary chamber through heat exchanger for saving in fuel
- Advanced modern PLC control or any suitable control system having facility to ensure safe combustion conditions throughout each cremation.
- Automatic temperature control of both primary and post combustion zones.
- Auto shut off of Fuel supply at the end of the Cremation cycle,
- Automatic fail safe against over temperature.
- Compact design, enabling easy installation & safe operations

Principle of Operation of a PNG based Cremator

- The dead body shall be laid on the hearth with the help of electro-mechanical trolley.
- The design of the PNG based gas furnace shall be considering the worst case scenario, i.e. considering the decomposed dead body with less fat than the normal.

The Primary burner housed in the primary chamber. The burners shall be mounted in the cremator facilitating access for maintenance and repair. The hearth in the primary chamber shall comprise of flat fire resistant tiles. (The maximum allowable operating temperature shall be about 1100°C to 1150°C). The hearth itself contains no openings, so that ash (in most of its volume) is retained in the primary chamber. The waste gas produced from this phase of the process exits the primary chamber & enters in the secondary combustion zone in which the post combustion takes place. The gases entering this zone shall then be heated by the secondary zone burner. Here it shall be treated by the introduction of additional air. The design of cremator post combustion zone shall ensure a lengthy, complex passage through the cremator prior to the flue gas exit. The flue gases make numerous passes within the secondary combustion zone, with the use of baffle walls

TECHNICAL SPECIFICATIONS M&E

in the flue path which ensure high levels of turbulence to promote complete combustion. It shall be capable of maintaining the flue gas temperature greater than about 850oC throughout the chamber, for a time greater than 1 second during operation. The post combustion of the flue gases is completed within these high intensity areas. While doing this all smells and smoke shall be eliminated. The compliance to the requirement of local environmental authority (such as MPCB/CPCB) shall be met.

Similarly emissions of Carbon Monoxide will be less than 100 mg/m³ at all times, as measured at reference conditions of 11% O₂, 1.013 Bar, 273.15K, dry on a volume basis.

Pre heated Combustion Air System

The cremator installation shall be supplied with combustion air by a fan passing through Stainless steel heat exchanger mounted at the outlet of furnace to recover heat from flue gases and put again in to furnace, with a design duty capable of providing the air pressure and flow requirements of the Cremator. The fan shall be located within an integrated enclosure within the cremator.

Instrumentation

Each burner shall be fitted with its' own air supply fan and individual combustion air pressure switches to supply to each burner.

The main chamber and secondary chamber temperatures shall be measured by type K thermocouples, temperatures all independently displayed on temperature instruments.

PLC Based Cremator Process Control

The cremator shall be supplied with a dedicated Programmable Logic Controller or any suitable control system. This controller shall supervise the safety features of the cremator and the combustion process. The cremator's control panel design shall be based upon a logic control.

The control enclosure shall be located on the side of the cremator. All the equipment shall be designed to minimize the effects of heat, and shall be adequately ventilated so ensuring trouble free operation.

The control system shall be capable of the total control of the cremator and all its functions in order to complete the cremation of the human cadaver, once the cremation chamber has been charged and so it shall simplify the day to day operation of the cremator. It shall automatically shut down the Fuel flow to the burner on the end of cremation cycle.

Cremator Process Control – Safety Features

The interlocks shall prevent the charging door being opened for the introduction of a “Dead Body” unless the temperature in the main chamber is below the set charging level or when the Burners are in 'Ignited' mode.

CREMATOR: Construction Description

Casing and Framework:

TECHNICAL SPECIFICATIONS M&E

The casing and framework of the cremator shall be fabricated from steel plate and sectional steel construction, the whole braced for rigidity, so as to properly support the refractory and insulating materials with which the casing is lined.

The combustion chamber including Charging Door shall be designed & manufactured such as not to allow any smoke/gas/liquid emerging out of furnace at any time during the entire process of Cremation. It will also lead to cleaner environment surrounding the furnace.

Cremator Loading Door:

The loading door fitted to the main chamber shall open to the full dimensions of the main chamber, allowing generously 'dead body' size. This door shall be suitably insulated to minimize outer surface temperature.

The door shall be situated at the front of the cremator and counter balanced and suspended on precision roller chains for ease of operation. Operation shall be by means of an electric motor controlled by adjacent push buttons, interlocked to prevent accidental opening of the charge door when burner is ignited or the temp inside the furnace chamber is not appropriate for operator. Manual over-ride shall also be provided for door opening. Appropriate locking arrangements shall be provided at this door to withstand the pressure created by both combustion chambers.

Ash Removal

Access for raking shall be through the Loading door. At the end of the cremation the door shall be opened by push button operation to a safe, partially open position, which shall protect the operator from the radiated heat of the chamber.

The ash then may be raked and removed directly via the external ash chute, into the ash container, which shall be positioned below the loading door. Therefore loading of Dead-body, and collection of remains shall be carried out at one and the same end of the cremator.

Gas Reticulation is in the scope of the manufacturer/tenderer.

Access for Maintenance:

The need for access for maintenance shall be carefully considered in the cremator design, and facilities shall be provided for the cleaning out of accumulations of ash in any of the chambers and flue passages, access ports being provided for this purpose.

External Finish: Externally, cremator's main casing shall be clad with SS 304 panels with thickness of min. 1 mm.

As well as giving the cremator a pleasing appearance, these panels shall be ensured operator safety, by preventing any hot surfaces from being touched. The external cladding SS 304 panels ensure a gap of air between the hot cremator casing, and the external surfaces, which can be touched. This shall greatly reduce the external surface temperatures.

TECHNICAL DETAILS OF FURNACE

Cremator main/primary combustion chamber dimensions: about 900 mm, about 880 mm High, about 2435 mm Long.

TECHNICAL SPECIFICATIONS M&E

The overall external dimensions of the cremator shall be generally about:

Length : about 3.50 meters

Width : about 2.00 meters

Height: about 3.50 meters

The approximate size of the isolated partition to house 1 no of PNG Gas Furnace is about 9Mtr (L) X 8Mtr (W) X 5Mtr (Ht)

The total weight of the cremator is about 11-15 Ton

Secondary Combustion Chamber volume: about 1.5 m³ .

Residence time in Post combustion chamber > 1 second

The post combustion chamber shall be specifically designed to ensure a flue gas residence time of about 1 second at a flue gas temperature of about 850 °C.

The approximate dimensions of the charging aperture are:-

Width: about 1.00 meters

Height: about 0.95 meters

REFRACTORY MATERIALS:

Refractories shall be of high quality, comprising fire-brick, semi-insulating Refractory and lightweight insulating refractory materials, backed by Calcium Silicate insulation at the furnace casing.

63% alumina content refractory tile shall be used for the main hearth and floor of the adjacent off take flue. This material shall be of a high resistance to abrasion and thermal shock, a maximum service temperature of 1600°C, bulk density 2.25 g/cm³, and thermal conductivity of 2.0 W/m.K. The thickness of this tile is 100 mm.

42% alumina content refractory shall be used in the side walls of the cremator. This material shall have a high resistance to abrasion and thermal shock, a maximum service temperature of 1400°C, bulk density 2.25 g/cm³, and thermal conductivity of 1.9 W/m.K.

Calcium Silicate Insulation : This material shall be used in the areas around the casing between the refractories and the steel casing. It shall have a maximum service temperature of 1050°C, a bulk density of 0.20 g/cm³, and a thermal conductivity of 0.10 W/m.K. The thickness of this insulating material is 100 mm.

Castable Refractory

Lintels, burner blocks and the flue gas outlet shall all be cast in a dense, medium alumina, high strength, high abrasion resistant castable refractory. These castable refractories shall have an alumina content of 50%, maximum service temperature of 1600°C, and bulk density of 2.37 g/c

The quality and thickness of the insulation shall be such that the cremator casing is kept at a safe temperature for the Operators.

TECHNICAL SPECIFICATIONS M&E

Best quality refractory materials shall be supplied & used. Moreover the Quality of the refractories shall be got certified by the tenderer as per applicable Indian Standards, during course of work, from government approved laboratory. The quality of the refractory shall be in-line with technical specifications of the respective manufacturer (i.e. Temperature, % of Alumina etc.).

Burners

Main chamber burner: 358 kW packaged type (with suitable blower) Max fire

Secondary chamber burner :358 kW package type (with suitable blower) Max fire

Burner fuel: Main fuel as PNG

Burner control mode- On/Off in Main chamber & high/ low as required in Secondary chamber. The Burners shall be ignited automatically and the burner system shall be protected against flame failure, thereby complying with the gas regulations. The Burner shall shut off the gas supply at the end of the cremation cycle automatically.

Flame detector: Ionisation probe

Utility / Fuel Consumption

Typical gas consumption of the cremator: not exceeding 20 SCM of PNG gas per cremation cycle including pre-heating. The cremation cycle shall complete in 90 minutes, generally.

Pressure required for Burner:- The burners shall be as per manufacturers design. However, the inlet pressure of **500 mbar** will be made available. The bidders shall provide suitable equipments to meet the pressure requirement of selected burners

Typical Electrical consumption: 5.0 kWh

Cremation Capacity

This design of cremator shall be robust, and it shall perform any number of cremations per day (24 hour basis), to meet the demand of the situation.

Cremator Heat Loss

The cremator shall lose heat to its surrounding environment. This heat loss is via convection, from all its surfaces, shall not be greater than 11 kW.

Technical Specifications of the Body Charging Trolley:

Body charging trolley shall be used for smooth loading of body in to furnace. Conveyor drive consists of Rolling drum, motor, gearbox, chains, rollers and wire mesh etc. Dead human body should be loaded on to the hearth by means of a suitable travelling trolley, body Loading Mechanism. An Electrically operated cantilever type loading arm, which shall be raised up to suitable height for loading in furnace by means of mechanical/hydraulic jack. Mesh belt for the conveyor shall be provided for laying the human dead body in the cremator in a dignified manner. The conveyor shall be Roller type. The bearing shall be heat resistant. The mesh belt shall be manufactured from Stainless Steel or Carbon steel of 10SWG. The conveyor motor shall be of suitable HP with suitable gear box for speed

TECHNICAL SPECIFICATIONS M&E

reduction. The body loading trolley shall be guided in to the furnace with the help of MS channels laid on the floor level.

Approximate Combustion Air Requirements		
Combustion air to main chamber	Modulating flow	
	Min flow 0 m ³ N/h	
	Max flow 250 m ³ N/h	
Secondary chamber air	Modulating flow	
	Min flow 0 m ³ N/h	
	Max flow 300 m ³ N/h	
Combustion air fan capacity	Volume	400 m ³ N/h
	Motor	0.75 kW
Cremator Process Data Temperatures		
Main chamber temperature	Min	700°C
	Max	1050°C
	Varies with progress of cremation	
Secondary chamber temperature	Design	850°C
	Max	1150°C
Pressure		
Static Under pressure main chamber about -1 to -7 mm water column		
Flue Gas Volume		
Ex post combustion chamber	about 1540 m ³ N/ h	
Flue Gas Condition		
Content of Carbon Monoxide		
Typical content over the cremation	<50 mg/Nm ³ (Using natural gas fuel)	
Flue Gas Particulate Content (typically)	<100mg/Nm ³	
All above figures are given at reference conditions of 273.15K, 1.013Bar, dry, 11 % Oxygen on a volume basis		
Cremator Controller /Instruments/Thermocouples		
Main chamber	No 1	Type K Ni / Cr Element
Secondary chamber	No 1	Type K Ni / Cr Element

Programmable Logic Controller or any suitable control system

TECHNICAL SPECIFICATIONS M&E

The Control system with suitable relay or any control logic or otherwise, such that it gives the all possible 'safety features and controls'. Safety & ease in process-control is the essence & accordingly safety features and operation controls incorporated in the schedule.

SUPPLY AND INSTALLATION OF GAS FIRED CREMATION FURNANCE :-

- 1) It is mandatory to the contractor to prepare the General Engineering drawing for PNG cremation work as per MCGM technical specification and getting approval for the same from authorised Govt. Authorities. After getting the same, the contractor shall submit the drawings to MCGM for approval.
- 2) The contractor shall use the proper bending material to fix the refractories inside the PNG furnace.
- 3) Conveyer set up should be proper with level of PNG furnace which success the cremation with respect for the same , the contractor shall specially maintain the operation level of conveyer.
- 4) After approval of drawing , contractor shall carry out the procedure with Mahanagar Gas Pvt. Ltd. (MGL) to get the pipe natural gas (PNG) connection at his own cost for two separate meters with separate gas pipeline connection from MGL.
- 5) The contractor shall confirm the place with site Engineer for PNG meter which ease to record the reading.
- 6) The contractor shall lay the proper size of pipe to connect the furnace with MGL meter by carrying out necessary excavation work at site. For PNG connection, if Gas pipeline required to be layed by crossing the roads, necessary excavation will be carried out by the contractor and for the same, necessary permissions from MCGM authorities and RTO department shall be carried out by the contractor with in the contract cost.
- 7) Any other services on roads if effected due to excavation work of MCGM, the same will be temporally supported by the contractor who must also take all measures reasonable

Required by the various bodies to protect their services and property during the progress of the work.

- 8) The contractor shall provide appropriate size of gate valve on gas pipe line near furnace and after MGL meter for their installation.
- 9) The contractor shall arrange proper size of tray of S.S. material to collect the Ash after cremation.
- 10) The contractor shall provide proper support to duct pipe and exhaust pipe of generator as per site Engineer instructions.
- 11) The contractor shall submit separate drawing for ETP plant and get approval before installation

TECHNICAL SPECIFICATIONS M&E

SUPPLY AND INSTALLATION OF BLOWER :-

- 1) The contractor shall submit factory test report of Air Blower.
- 2) The contractor shall supply & install the Air blower as per size mentioned in technical specification.
- 3) Air Blower for PNG system should be work smoothly. Any noise from the system will not be ignore.

SUPPLY AND INSTALLATION OF SCRUBBER AND WATER TANK:-

- 1) The contractor shall supply and install scrubber system as per technical specification.
- 2) Proper size of water pipe line to be provided to scrubber to get water pressure.
- 3) The contractor shall provide appropriate size of motor for scrubber system/mentioned H.P. of motor in the technical specification to suck the air sufficiently & deliver the same into the water flow.
- 4) The contractor shall ensure the delivered water from the scrubber properly connect to the ETP for further process.
- 5) The contractor shall provide proper size of water tank as mentioned capacity in the specification with proper make. Water tank should be ISI marked.
- 6) The contractor shall provide duct in S.S.304 material from furnace and connect the same to existing chimney through scrubber system.
- 7) Proper support in M.S. angle (appropriate size with duct) should be provided to the duct, M.S. angle supports to be provided to the duct at every 3 meters . Each supports should be properly fitted with anchor fastener.
- 8) Duct in S.S.304 shall be properly moulded no burns or cuts on duct pipes are allowed.

Technical Specification of the Blowers

The Centrifugal fan will be of SS 304 casing (min. 2mm thk) and SS 304 impeller (min. 3mm thk), which shall be directly coupled to motor fixed on the frame. The capacity of fan shall be 3500 NCu.m/hr with 200 mm pressure.

The tenderer is free to quote his own suitable design & accordingly state the technical details in the appended schedule.

Technical Specifications of a Scrubber:

The Furnace system shall be incorporated with vertical cyclo-ventury scrubber system for the pollution free discharge of the flues from the furnace of the crematorium.

TECHNICAL SPECIFICATIONS M&E

The exhaust gasses coming out of furnace which are hot dust laden gases coming from flue duct passage shall be connected by required size of SS 304 duct. It shall be passed through efficient ventury type water scrubber to control the pollution as per the mandatory norms of environmental authority (MPCB/CPCB). These gasses are conveyed into the section where spray nozzles introduce water in such a manner that the incoming gases impinge on the water quenching them to a point at or near the saturation temperature of the gas. Due to the high degree of turbulence, atomization and impact at the throat, the dust particles shall be effectively removed from the gas stream and same shall be entrapped in the water droplets. Further the mist eliminator shall be provided to reduce the water droplets enter into the blower casing.

The inlet and outlet ducting of the scrubber shall be made out of SS 304. It will suck the flue from the furnace through scrubbing system and the outlet connected to the chimney. The Scrubber shall be efficient & capable of scrubbing Particulate contaminates & shall limit upto concentration of 100mg/Nm³. The scrubber shall be manufactured out of SS 304 sheet of 3 mm thick complete with suitable capacity water pump.

The water scrubber shall be self-supporting type with water spray nozzles complete with inlet and outlet GI C class piping, valves.

A water tank above ground level of 4000 liters with cover and piping connection to scrubber and adequate facility to drain shall be provided.

The scrubbed liquid shall be treated prior to letting into the Municipal sewer network where the norms of MPCB shall be met with.

Water Requirement for Scrubber:

The re-circulation system for water shall be provided due to which consumption of water should reduce considerably. The re-circulating system consist of filter, piping RCC Tank/MS tank lined with anti-corrosive lining from inside, water pump etc. shall be fixed below the scrubbing system.

Technical Specifications of the Chimney for one furnace

It shall have self supporting MS construction with RCC Foundation having 30 mtr height with about 620 mm dia at bottom , about 350 mm dia at top shall be supplied along with its foundation bolts. MOC of chimney is Carbon steel plate 6 to 10 mm. Foundation bolts shall be of EN 8 material.

The chimney shall be as per IS: 6533 Part I & II. Its MS structural members shall be as per IS 2062:1999 &

The chimney shall be provided with copper lighting Arrestor and provision (with ladder & platform with GI Railing) to check the emission level of the flue gas at height of about 13mtr. Aviation light shall be provided to the chimney. Complete chimney structure shall be painted, with one coat of heat resistant anti rust primer and two coats of heat resistant Aluminium based paint on silicon resin medium from inside and 3 coats outside surface. The tenderer shall study the site conditions, testing soil-bearing capacity, strength of civil structure, before designing foundation for achieving stability of furnace and M. S. chimney. The foundation design shall be done through registered structural engineer, approved by MCGM and the

TECHNICAL SPECIFICATIONS M&E

work will be carried out under supervision. of appointed structural engineer .The structural stability certificate for this shall be submitted after completion of work. RCC foundation drawing shall be got approved from the licensed Structural Engineer on approved list of MCGM at Contractors cost. The Structural Stability Certificate as mentioned above shall be handed over to MCGM, after completion of the work.

The Scrubbed Flue gases emerging out of the Chimney shall be treated prior to letting into the environment, where the norms of MPCB ie Ambient Air Quality (AAQ)

Standards shall be met with.

Technical Specifications of the common Chimney for two furnaces

The common chimney shall be of self-supporting MS construction with RCC Foundation having 30 mtr height for two furnace about 820 mm at bottom and about 500 mm at top shall be supplied along with its foundation bolts. MOC of chimney is Carbon steel plate 6 to 10 mm. Foundation bolts shall be of EN 8 material.

The chimney shall be as per IS: 6533 Part I & II. Its MS structural members shall be as per IS 2062:1999 & accordingly state the technical details in the appended schedule.

The chimney shall be provided with copper lightning Arrestor and provision to check the emission level of the flue gas at height of 13 mtr. Aviation light shall be provided to the chimney. The tenderer shall study the site conditions, testing soil-bearing capacity, strength of civil structure, before designing foundation for achieving stability of furnace and M. S. chimney. The foundation design shall be done through registered structural engineer, approved by MCGM and the work will be carried out under supervision of appointed structural engineer .The structural stability certificate for this shall be submitted after completion of work. RCC foundation drawing shall be got approved from the licensed Structural Engineer on approved list of MCGM at Contractors cost. The Structural Stability Certificate as mentioned above shall be handed over to MCGM, after completion of the work.

The Scrubbed Flue gases emerging out of the Chimney shall be treated prior to letting into the environment, where the norms of MPCB ie Ambient Air Quality (AAQ) Standards shall be met with.

Technical Specifications of Ducting:

The ducting shall be provided to complete the interconnection of the cremation system. It shall be of SS 304, with thickness of 2mm & diameter of about 300mm.. These ducts shall be provided with suitable dampers and fittings such as tees, elbows, bends etc. These ducting shall be laid & fixed with a suitable support from the hall or shed at no extra cost. These supports shall not cause any harm to the hall or shed.

Technical Specifications for Testing & Commissioning of the Cremation system:

a) The tenderer shall complete the inter connection between furnace and scrubber and Scrubber to chimney through suitable ducting of SS 304 as per the Technical specifications & site conditions. The cremation furnace offered shall have proper arrangements and layout suitable for complete cremation. All written and unwritten laws of ethics and hygiene shall be adhered to from start to finish of the cremation process. The human dead body shall be

TECHNICAL SPECIFICATIONS M&E

offered inside the combustion zone with the help of an electrically operated trolley. The complete cremation cycle (including Pre-Heating) shall be performed in about 90 minutes, generally by consuming about not more than 20 SCM of Piped Natural Gas. Cremation, shall take place without intervention of human being except-Charging the body and removal of last remains (ash and bones) of human body. Cremation furnace shall be safe in operation with all possible safety interlocks. The cremation shall be performed without causing smoke nuisance to the surrounding area. The furnace shall be having features to ensure full compliance to the Environment Protection Act 1986 by Ministry of Environment & Forests; Govt. of India obligations .It shall give emission result for Flue Gas Particulate Content not more than 100mg/NM3.

b) The tenderer shall complete the inter connection between 2 furnaces and scrubbers and its independent scrubbers to the common chimney through suitable ducting of SS 304 as per the Technical specifications & site conditions. The cremation furnace offered shall have proper arrangements and layout suitable for complete cremation. All written and unwritten laws of ethics and hygiene shall be adhered to from start to finish of the cremation process. The human dead body shall be offered inside the combustion zone with the help of an electrically operated trolley. The complete cremation cycle (including Pre-Heating) shall be performed in about 90 minutes generally, by consuming about not more than 20 SCM of Piped Natural Gas. Cremation, shall take place without intervention of human being except-Charging the body and removal of last remains (ash and bones) of human body. Cremation furnace shall be safe in operation with all possible safety interlocks. The cremation shall be performed without causing smoke nuisance to the surrounding area. The furnace shall be having features to ensure full compliance to the Environment Protection Act 1986 or latest, by Ministry of Environment & Forests; Govt. of India obligations .It shall give emission result for Flue Gas Particulate Content not more than 100mg/NM3.

The tenderer shall give the cost of Operation Separately from 1st Year to 5th Year. Also the tenderer shall give the CSMC rates separately from 2nd Year to 5th Year.

The lowest bidder's design for furnace & its allied APC system & ETP shall be got vetted from Third Party Technical Experts such as VJTI, Mumbai or IIT, Mumbai at tenderer's own cost. No separate charges shall be paid by MCGM towards the same. All the suggestions of the technical experts shall be incorporated by the bidder at his own cost.

Mandatory periodic monitoring tests & assessments are to be carried out & submitted to the MCGM & concerned Pollution Control Board Authority at Tenderer's own cost.

No separate charges shall be paid by MCGM towards the same.

The MCGM Staff (10-20 Nos.) shall be trained for complete operation of PNG Furnace system for the period of 1 Month.

2PNG Furnaces (1 Working + 1 Stand By)

After providing suitable foundation, its curing & after clear site access , the work of Supply & Installation of Furnaces shall be carried out by the successful bidder. Thereafter the work of Testing & Commissioning shall be carried out as per Technical Specifications, additional Technical Specifications as mentioned here & as per site conditions.

TECHNICAL SPECIFICATIONS M&E

The 15 kVA DG set is to be provided with each Furnace. So that in case of interruption of Electric Supply from Supply Company, the Cremation process shall not halt. The necessary interconnection with Body Loading Trolley motor, Supply Air Blower motor, Gas Supply Solenoid, Burner Ignition, Scrubber Pumps, Exhaust fan motor etc shall be incorporated into the Furnace panel's Logic Control.

DG set shall be provided with all the switch-gears & control cabling for successful commissioning of DG Set. Also the interconnection between DG Set, its AMF panel & PNG systems control Panel shall be in the scope of successful bidder. 15 KVA DG set shall be included of suitable size cables, their glands, excavation, switchgear at service, earthing, separate diesel tank, hand pump, buckets etc shall also be provided by the successful contractor.

To cover open duct, cable duct, channels in crematorium room, for support etc, the item of M.S. plates shall be provided by the successful contractor if required.

The excavation for Gas pipe laying as well as Electric Cable laying route, within the compound of Crematoria under reference, shall be duty of the contractor along with the reinstatement of the trenches & resurfacing of the dug area.

The alternate Fuel usage of LPG Gas System is now differed from the Scope of Work in view of User Department's requirement that they are going to retain some of the wood pyres.

The said work of internal Gas pipe laying shall be carried out through the MGL approved Gas pipe laying Contractor. The CFO NOC shall be obtained by MGL approved Contractor. It is mandatory to obtain the NOC from CFO department.

Release of Gas supply from MGL is responsibility of the contractor. The laying of internal gas Pipeline from Gas meter (to be installed by MGL inside cemetery) upto the proposed Gas Furnace is in the scope of this tender. This work shall be carried out as per MGL's terms & conditions & as per CFO's requirements. To bring piped Natural Gas upto Gas meter is MCGM's responsibility. However Release of Gas supply from MGL's Gas Meter shall be responsibility of the tenderer, after getting required clearances from M/s.MGL.

The Furnaces & Trolleys with APC units (excluding 30 Mtr tall Chimney) shall be installed within the Hall.

The Chimney shall be provided with aviation light, Lightening arrester & shall be as per requirement of Indian standard.

The design of pipe natural gas cremation furnace shall be made to a like quality, long life, pollution control, effect based on factors, time saving, space requirement and above all complete cremation and satisfaction to the mourners with least electrical power and PNG consumption.

The Scope of work includes SITC of pipe natural Gas (PNG) cremation Furnace complete with interconnection of Chimney, Wet scrubber system, flue gas ducting system and Burners, accessories for connecting various part of the furnace system. The Furnace shall be provided with Alarm and Auto shut off of main PNG gas supply valve.

TECHNICAL SPECIFICATIONS M&E

All written and unwritten laws of ethics, religion and hygiene shall be strictly adhered to cremation process.

Cremation process shall be complete & as rapid as possible.

There shall be no manual intervention in the entire process of cremation.(ie after body is offered in the chamber & doors of the furnace are shut.)

The supplied PNG cremation furnace shall have proper arrangements and suitable for complete cremation of human dead body of average 70 kgs effectively, in hygienic manner and with due respect to the dead and without causing smoke nuisance in the hall area during cremation.

Pipe nature gas cremation furnaces shall be consisting of mainly fully automatic burners at least one in primary combustion chamber and at least one in secondary chamber with necessary piping, pressure gauge, gas train. All the PNG gas related joints shall be leak proof and tested as per terms and required norms stipulated by Gas Supply Company.

The flue gases after being sucked from the furnace shall be brought to the inlet of wet scrubber through ducts as per suitable size & norms. After Scrubbing the flue gas, it shall be routed to Chimney via exhaust blower of suitable capacity before letting the smoke into atmosphere. The parameters of smoke shall be within the permissible limits as stipulated by MPCB.

It is to be noted by the successful bidder the cost of scrubber and blower is inclusive of cost of cables, earthing, switch-gears, required piping all complete with required accessories for successful installation of the scrubber and blower.

Electrical contractor shall submit test reports, earthing test report, SLD and other required reports to electric supply company (BEST/MSEB/RELIANCE etc) and follow up the matter with them to get release the electric supply. The matter shall be followed up with electrical inspector (PWD) if required to do so.

Material Specification: for PNG Pipe Line

All material used should be of following specifications otherwise specific approval is required from MGL engineer.

- a) Pipe: Carbon steel ERW pipe IS 1239 class C (Tata/ Zenith /Jindal make)
- b) Fitting: All fittings should be seamless.
- c) Isolation Valves: Full bore ball valves Make: ITAP/ AUDCO/ VIRGO/OMEGA
- d) Flexible Hose: For connection more than one natural draught burners (i.e. bhattis) SS braided SS below pipe of 1" size and length not more than 1 foot should be used. For connecting one single canteen burner MS braided flexible hose of 1/2" size and length not more than 3 feet should be used. All forced draught burners (mono block burners) should be connected with SS braided SS below pipe of suitable size.

Installation Requirement: for PNG Pipe Line

- a) All pipe work should be vertically & horizontally aligned. Pipe should be properly clamped and should rest on MS clamps provided at distance of every 1 meter.

TECHNICAL SPECIFICATIONS M&E

- b) A safe gap of 1" should be maintained between pipe and wall.
- c) Pipe to be painted with anti corrosive yellow epoxy paint with pre coating of red oxide.
- d) Meter should be supported properly on meter brackets & inlet / outlet pipe line should be vertically aligned.
- e) Test pressure tapping of (1/4 ") should be provided before meter.

The work of Pipe laying of respective pipe sizes thus shall be carried out as per technical specification & requirements stated time after time by M/s. MGL as per their requirements.

The operation part of contract will be awarded only if necessary. MCGM is not bound for any relief /compensation if there is any work reduction in the scope /Quantum of operation work or if no operation work is awarded at all.

Please note that any other material required for successful installation, testing & commissioning of the work shall be borne by the successful contractor without any extra cost to MCGM.

For achieving successful 'Annual Comprehensive Servicing & Maintenance Contract', if any corrective action is required the same shall be taken by successful bidder for achieving the pollution norms as per pollution control board at his own cost.

All the interconnection for 'Passage of flue gas' through duct is in scope of successful, bidder. ie. The successful bidder shall make the interconnection between Furnace outlet, scrubber, and blower up to the chimney suitably.

Furnace systems are provided. If both systems remain non-operative due to any reason (except non availability of PNG from supplier or flood or act of god) for the period of more than 24 hours then, the penalty of Rs.5000 /- per day will be imposed to the successful bidder/tenderer

Penalty Clause: Please note that for Penalty Calculation, it is considered as 60 Bodies are offered per furnace per Month. As mentioned in Technical Specifications the PNG consumption must not exceed 20 SCM per cremation cycle. If it is observed during Testing & Commissioning stage that the average PNG consumption for Cremation of 15 Human dead bodies is more than 20 SCM, then as penalty the excess SCMs shall be penalized & deducted in following manner from the Payment to the Contractor.

= Difference in SCM (SCM in excess of 20) X 60 Bodies per month X 12 Months X10 Years X 75 Rs/SCM.

Cremation cycle can be defined as Pre-heating + Main Cremation Cycle .The cycle shall begin at close of the Furnace Door. The cycle shall end when the Human Dead body is reduced into 'acceptable-form' of ashes, as per written and unwritten laws of ethics & religion.

TECHNICAL SPECIFICATIONS M&E

SPECIFICATIONS FOR COMPREHENSIVE SERVICING & MAINTENANCE CONTRACT FOR FIVE YEARS AFTER COMPLETION OF 1 YEAR FREE GUARANTEE PERIOD

A) FOR “PNG FURNACE SYSTEM”

The comprehensive maintenance of PNG furnace system and allied equipments on daily, weekly, monthly, quarterly & annual basis shall be done as stated below. The scheme also envisages replacement of gear oil, lubricants, cotton wastes, hardware, nut bolts & bearings, etc. and other items required for successful running of PNG furnace like control panel equipments viz. relays, contactors, switches, indicating lamps, wires, cables, timers, etc. except blower impeller & shaft.

I GENERAL

- (i) The contractor shall carry out servicing, repairs and maintenance of PNG furnace to render trouble free uninterrupted services to the user department as per their requirements.
- (ii) Attend the break down calls whenever called by the Corporation free of cost.
- (iii) The contractor shall replace the spares of all the equipments related to the PNG furnace if found necessary at their cost.
- (iv) The contractor shall clean the premises, after carrying out servicing works. No material, dirt, caused during servicing shall be left in the premises.

- (v) The contractor shall submit the copies of service reports to concerned MCGM authority every month for the services rendered to PNG furnace at various locations.
- (vi) The contractor shall carry out the work in office hours i.e. 9.00 a.m. to 5.00 p.m. on normal working days & from 9.00 a.m. to 1.00 p.m. on Saturday. In case of urgency the contractor will have to work even after office hours and on holidays.
- (vii) The complete risk of human life and the Material supplied while carrying out the service & maintenance of the subject systems will be borne by contractor for their employees. Any damages caused to the municipal property will be recovered from the bills of the contractor.
- (viii) Any break down complaint of the systems shall be attended within shortest possible period depending upon nature of faults.
- (ix) The successful contractor shall service, maintain the PNG furnace during the contract period as per the requirement of Corporation. Any defects, rectification which was required to be attended during the contract if observed within 3 months after expiry of contract, the same will be carried out at the risk and cost of the contractor and the charges for the same will be recovered from the bills or security deposit.
- (x) The successful tenderer shall, after completion of free maintenance period, submit a performance bank guarantee amounting to 5% of the quoted cost for the comprehensive annual servicing & maintenance for the five years period.

TECHNICAL SPECIFICATIONS M&E

- (xi) The contractor shall direct their said personnel as per scheduled program, given and approved by user department, to the above said PNG system once in a month during working hours to examine, lubricate and adjust the equipments, in presence of concerned person of user department. The contractor shall maintain record of all the repair, servicing and maintenance works carried out and shall submit the necessary log-cards duly signed and stamped by authorized person of user department to concern MCGM authority.
- (xii) While doing any maintenance work of the PNG furnace/gas line/its control panel etc.; the contractor shall first ensure that emergency stop push Button is operated or main selector switch is in off condition.

II Maintenance Schedule

a) **Weekly maintenance:-** The contractor shall clean, grease, tighten the nut bolts and clean the scrubber nozzles, drainage line, etc.

Contractor shall check the connection from PLC panel to burners & motors.

b) **Monthly maintenance:-**

- (i) Contractor shall open the blower and scrubber and control panel, and Clean to remove dust particles, also grease all moving parts & reassemble the equipments.
- (ii) Contractor shall check up the gas lines for leakage of fuel gas and also leakage occurring in gas connections in control panel.
- (iii) Contractor shall check thermocouple fitment in the furnace.
- (iv) Contractor shall set burners ignition sequence & Flame sensing.
- (v) Contractor shall check and clean refractory works, cementing the same if essential so as to cover gaps/cracks if found developed.

c) **Quarterly maintenance:-**

- (i) Servicing of Scrubber- The Contractor shall dismantle the Scrubber i.e. Remove, clean, refix and align the nozzles. Non working nozzles shall be replaced. The overall cleaning of the scrubber shall be done.
- (ii) Servicing of blower- The Contractor shall dismantle the blower assembly, clean the impeller and dynamically balance. The belt tension and pulley shall be checked and align properly. All the fasteners shall be tightened and replaced if necessary.
- (iii) Servicing of control Panel – The control Panel shall be cleaned and checked. The electrical contact shall be sprayed with CRC. The nonworking parts and meters shall be replaced.
- (iv) Earth Pit:- The Earth Pit shall be cleaned and checked and watered to maintain the required earth resistance within the prescribed limits.

TECHNICAL SPECIFICATIONS M&E

d) Six monthly maintenance:-

The Contractor shall dismantle the blower & scrubber to clean and remove the foreign particles and readjust and assemble the unit.

e) Yearly maintenance: -

- (i) The contractor shall overhaul and service the scrubber, blower, and other plant & machinery as per direction of Engineer.
- (ii) The painting of PNG equipments like blower motors, Chimney, Sump tanks & equipments shed shall be done as per direction of engineer.
- (iii) The contractor shall change the battery of PLC after every 12-15 Months.
- (iv) The successful tenderer shall carry out the Emission Test (Stack gas analysis) and scrubber efficiency test from the authorized laboratories approved/recognized by MPCB/CPCB/Ministry of Environment once every year. The emission result shall prominently display the concentration of total particulate matter in flue gas at entry & outlet of the scrubber. The concentration of various gases viz. Hcl, Hf, SO₂, CO₂, NO₂, CO, Lead, Mercury, etc. shall be documented and the same shall be within the permissible value otherwise necessary corrective action shall be taken by the contractor without any extra cost.
- (v) Ultrasonic test for chimney shall be taken as per norms and test certificates shall be submitted, the cost is inclusive; no extra charges will be paid.
- (vi) The painting work of chimney includes removing of mill scales & rust with suitable mechanical tool/scrubber & wire-brushing and chipping to remove loose rust & scale. The paint shall be heat-resistant paint and shall withstanding temp. up to 250⁰ C. Three coats shall be applied so as to have a uniform thickness & have aesthetic look. Sufficient time i.e. minimum 24 hrs. shall be allowed between successive coating.
- (vii) The successful contractor shall paint sump tank of 4000 Ltr. capacity with chlorinated rubber paints after awarding the contract within three months period and get it inspected by Municipal engineer.
- (viii) The contractor shall note that all fast consumable spares & material like caustic soda shall be kept with them in stock and replace whenever required. The same shall be included along with the cost of spare in the offer. The tenderer shall submit their offer inclusive of all spares/parts required for comprehensive maintenances of plant & machineries necessary for smooth & trouble free operation.
- (ix) The performance of the contractor shall be reviewed after completion of every six months, & if not found satisfactory, the MCGM reserves the right to terminate the contract with one month's notice. It is also essential on the part of tenderer to inspect the site before submitting the offer and no claim shall be entertained on account of ignorance later.

TECHNICAL SPECIFICATIONS M&E

B) FOR “ETP SYSTEM”

- a) **Weekly maintenance :-** The contractor shall clean, grease, tighten the nut bolts and clean the agitator/stirrer, effluent transfer pump, filter feed pump etc.
- b) **Monthly maintenance :-** Contractor shall check up the pipe lines of ETP for leakages if any and attend the same if detected. Contractor shall open and clean control panel of ETP, all valves and grease all moving parts of the same.
- c) **Quarterly maintenance :-**
Contractor shall clean filter every six month or as recommended by filter manufacturer.
- d) **Yearly maintenance: -**
- (i) The contractor shall overhaul ETP and its plant & machinery as per direction of Engineer or as recommended by its manufacturer.
 - (ii) The painting of ETP equipments like pump, motor, MS tanks etc. shall be done as per direction of engineer.
 - (iii) The contractor shall clean all the tanks of ETP every year.
 - (iv) The contractor shall clean sludge drying beds of ETP every year.
 - (v) The contractor shall carry out the pollution concentration test from the authorized laboratories approved/recognized by MPCB/CPCB/Ministry of Environment once every year. The concentration of various pollutants shall be documented and the same shall be within the permissible value prescribed by Environment Protection Act, 1986, otherwise necessary corrective action shall be taken by the contractor without any extra cost.

Penalty and terms of payment for C.S.M.C. of PNG Furnace System, ETP and allied equipments:

Penalty for CSMC:-

If the PNG furnace system, ETP and allied equipments remains under breakdown for more than 48 hours, Maint. Charges will not be paid for the break down period. In addition a penalty of Rs.1000/-per day will be levied after 48 hours of break down for not attending the breakdown.

Terms of Payment For CSMC:-

Service during the quarter period shall be billed by the contractor at the end of quarter and on receipt of bill will be paid within thirty days as per M.C.G.M. procedure.

This contract is terminable by MCGM if the services rendered are unsatisfactory. In case of dispute, the Municipal Commissioner's decision will be final and binding on both the parties.

TECHNICAL SPECIFICATIONS M&E

COMPREHENSIVE SERVICE MAINTENANCE CONTRACT (CSMC) OF THE COMPLETE SYSTEM -

- 1) The contractor shall visit twice in a month at cemetery and check the working of the Auto / manual operation of the control panel, operation of trolley, operation of the scrubber system, Auto/manual operation of the furnace door, Ash tray, water tank of the scrubber, water connection line of water tank, discharged from scrubber, ETP operation, discharged air from chimney and report to the site Engineer.
- 2) To check all refractories fitted inside the furnace at every month and carry out it necessary repairing, cementing or ending process for refractories.
- 3) To check Auto/ Manual door operation of the furnace and carry out necessary cleaning of channel from door to be run. Proper oiling and greasing to be done to outer chain pulley block arrangement at every month.
- 4) The contractor shall check scrubber system including water connections. .
- 5) The contractor shall check ETP operation at every month and take water sample from scrubber system and check the water quality of discharged water .
- 6) The contractor shall attend / and check operation of DG set at every month and run the furnace on DG supply for testing.

SPECIFICATIONS FOR OPERATION FOR FIVE YEARS

A) PNG Furnace System:-

Scope of Work :-

The work comprises of the following: Operating the PNG Furnace system and allied equipments round the clock (Day & Night) for 365 days a year without break or holidays in an approved manner by deploying sufficient manpower. The operation of PNG Furnace system needs to be strictly as per manufacturer/suppliers operation manuals for the desired efficiency. At any given time of operation the exhaust gases coming out of stack should be within norms of pollution control authorities/any other authority dealing with this. The scheme also envisages replacement of consumables.

Operation : -

- (i) The contractor shall utilize the services of trained, skilled personnel who will be directly employed and appointed by the contractors. They shall be qualified and experienced to keep the entire PNG furnace system in proper working condition. They will also take all responsible care to maintain the equipment in efficient, reliable, neat, tidy and safe operational condition.
- (ii) The contractor shall maintain the record of operating hours of all the equipments, parameters like voltage, current, energy, temperature, gas flow, pressure etc. and shall submit the copy of it to the concern office.

TECHNICAL SPECIFICATIONS M&E

- (iii) The staff posted for operation and maintenance shall wear uniform, which shall be got approved from MCGM authority before use. They shall always wear Identity card prepared by the contractor and signed by MCGM authority.
- (iv) The persons/employees deployed for operation and maintenance shall be covered as per Contract Labour (Regulation & abolition) Act 1970 and registered with the Labour Commissioner.
- (v) The contractor shall have to provide safety equipments to its personnel and they will also be adequately insured.
- (vi) Maintain cleanliness surrounding the PNG furnace area and surrounding of scrubber, chimney etc.

Contractor shall remove the ash from PNG furnace after every cremation.

B) Operation of ETP: -

Scope of Work:

The work comprises of the following: Operating the ETP plant and allied equipments round the clock (Day & Night) for 365 days a year without break or holidays in an approved manner by deploying sufficient manpower. The operation of ETP system needs to be strictly as per manufacturer/suppliers operation manuals for the desired efficiency. At any given time treated effluent from ETP should be within norms of pollution control authorities/any other authority dealing with this. The scheme also envisages replacement of consumables.

Operation: -

- (i) The contractor shall utilize the services of trained, skilled personnel who will be directly employed and appointed by the contractors. They shall be qualified and experienced to keep the entire ETP in proper working condition. They will also take all responsible care to maintain the equipment in efficient, reliable, neat, tidy and safe operational condition.
- (ii) The contractor shall maintain the record of operating hours of all the equipments, parameters like voltage, current, energy, temperature, gas flow, pressure etc. and shall submit the copy of it to the concern office. The consumption of treatment chemical shall also be logged.
- (iii) The staff posted for operation and maintenance shall wear uniform, which shall be got approved from MCGM authority before use. They shall always wear Identity card prepared by the contractor and signed by MCGM authority.
- (iv) The persons/employees deployed for operation and maintenance shall be covered as per Contract Labour (Regulation & abolition) Act 1970 and registered with the Labour Commissioner.
- (v) The contractor shall have to provide safety equipments to its personnel and they will also be adequately insured.
- (vi) Maintain cleanliness surrounding the ETP.

TECHNICAL SPECIFICATIONS M&E

Penalty and terms of payment for operation of PNG Furnace System, ETP and allied equipments:

Penalty:-

The contractors personals shall operate the plant day and night (round the clock for 365 days a year) as & when necessary. If contractor fails to provide the staff round the clock, a penalty of Rs.1000/-per shift will be levied without any reference and operation charges will be deducted on prorata basis

Terms Of Payment For Operation

Service during the quarter period shall be billed by the contractor at the end of quarter and on receipt of bill will be paid within thirty days as per M.C.G.M. procedure.

This contract is terminable by MCGM if the services rendered are unsatisfactory.

In case of dispute, the Municipal Commissioner's decision will be final and binding on both the parties.

FINAL TESTING AND COMMISSIOING OF THE SYTEM WITH 1 FURNACE & CHEMNEY.

To check the following points at the time of final testing:-

- 1) Inlet gas pressure at MGL burner.
- 2) Pressure available at Gas burner of the furnace.
- 3) Auto operation of PNG furnance.
- 4) Manual operation of PNG furnace.
- 5) Manual door operation of the furnace.
- 6) To check the scrubber system.
- 7) To check the operation of ETP.
- 8) To register the time to start cremation & end of cremation.

Dismantling of Chimney:-

Dismantling of Mild Steel Self supported chimney for Electric / PNG crematorium or for APC system used for wood pyre. To be dismantled by large crane with gas cutting without any damage to other machinery and human in cemetry premises. Breaking of old concrete foundation of self supported chimney. All debris shall be cleared from site. Excavation area will remain as it is after completion of excavation.

TECHNICAL SPECIFICATIONS M&E

DISMENTLING & REMOVAL OF FURNACE , INSULATION MATERIAL, HEATING ELEMENTS, PANEL ETC.

- 1) The contractor shall remove furnace refractory , insulation material, heating elements, control panel with cabeling water scrubber system & disposed off the material at his own cost.
- 2) The contractor shall disconnect dismantling work in presence of PWD lic. Holder person.
- 3) Water scrubber system to be removed after disconnection of water pipeline. The contractor shall properly plug the existing water connection.



TECHNICAL SPECIFICATIONS M&E

SP-ME-TS-63AIR CONDITIONING WORKS:

(R3-ME-9-1 to R3-ME-9-117)

1) WINDOW MODEL AIR CONDITIONING UNITS

- (i) These specifications cover the general technical requirement for Window model Air Conditioning unit of various capacities generally available in 1.0 TR, 1.5 TR and 2.0 TR with their associated work.

The window model air conditioner shall be suitable to work on 230 Volts +/- 10%, 50Hz, single phase A.C. supply capable of performing the following functions:

- a) Cooling
 - b) Dehumidifying
 - c) Air circulating
 - d) Filtering
 - e) Ventilation
- (ii) The window model air conditioning unit shall be fitted with hermetically sealed in type suction cooled rotary compressor units with suitable rated capacitor start electric motor which would start unloaded and shall be equipped with built in type overload protection. The compressor shall be mounted on resilient mountings for quiet operation. Compressor shall conform to IS. 10617 (part – 1): 1983 with amdt.1 & 2.
- (iii) The cabinet of the air conditioning unit shall be made from either galvanized M.S. sheet of 1 mm thick or aluminium alloy sheet of 1.2 mm thickness or non-corrosive CRCA 18G sheets of 1.0 mm thick. The sheet shall be provided with stiffness for robust construction and shall have rounded corners. The surface treatment of the cabinet shall epoxy coated polyester or the sheet shall be suitably phosphated and protected by powder coated paint
- (iv) The galvanized steel sheet shall conform to relevant IS and coating grade of 120 gms/sq. mtr.
- (v) The window model air conditioning unit shall be complete with automatic temperature control / full function remote control and cut-in & cut-out and shall be provided with thermostat to enable room temperature to be controlled at any desired level between 15 °C to 30°C, ± 2 °C. The thermostat shall conform to relevant IS.
- (vi) The filter provided shall be easily removable and shall be cleanable type and synthetic make.
- (vii) The overall power factor of the units shall be 0.85 at capacity rating test conditions.
- (viii) The cooling capacity for compressors shall be as under: -
- a. For 1.0 Ton AC: 3204 Kcal/ hr./ 12000 Btu/hr or 3.51 kW
 - b. For 1.5 Ton AC: 4500 K.cal./ hr./ 18000 Btu/hr or 5.27 kW
 - c. For 2.0 Ton AC: 6050 K.cal./ hr./ 24000 Btu/hr or 7.03 kW

TECHNICAL SPECIFICATIONS M&E

- (ix) Energy Efficiency ratio for compressor shall be 2.625 K.cal./hr /watt. (min) Energy Performance Standards for Window Air Conditioners- Min. 2 stars and above.
- (x) The window model air conditioning unit shall be capable of operating satisfactorily in tropical climate under maximum ambient temperature of 46°C and humidity up to 90% (These two severe conditions not occurring simultaneously). The maximum operating conditions for which the window model air conditioning units are designed should be;
 - a. Outside air temperature: 35 °C (95°F) DB & 28.3 °C (83°F) WB.
 - b. The desired temperature and Relative Humidity inside the conditioned space shall be $24 \pm 1.6^{\circ}\text{C}$ ($75^{\circ}\text{F} \pm 2.8^{\circ}\text{F}$) and $55 \pm 5\%$ (not controlled) respectively.
 - c. The window model air conditioning unit shall have low noise level confirming to relevant IS.
 - d. The successful contractor will offer inspection at site for each unit with respect to performance specified, workmanship and quality of material as stipulated.

INSTALLATION

The necessary openings for housing the units, providing T.W. framework or by breaking open the wall, if necessary. After installing the units, the remaining portion of the opening shall be blanked off and painted with colour to match the surroundings. G.I. Drip Trays with insulated P.V.C. drain pipes of adequate length and size for carrying away the condensate water depending upon the site conditions shall be provided. The contractor will have to make good without any extra payment any damage / loss to the Municipal property while executing the work.

Metal work such as angle frames, brackets etc. shall be properly cleaned degreased pickled phosphated and applied with one coat of anti-corrosive red oxide and 2 coats of synthetic enamelled paint of approved make and shade. If the surrounding atmosphere is corrosive, the finishing paint shall be corrosion resistant for the type of atmosphere. This item shall be included in the above work, as no separate payment to this effect will be made.

INSPECTION AND TESTING

Inspection & testing of A.C. units & accessories shall be carried out as specified or permitted in the relevant standard, unless otherwise specified and shall be carried out as specified in GS-5.1 i.e. (Inspection and Tests) for Air conditioning work.



WINDOW MODEL AIR CONDITIONING UNITS

2) SPLIT AIR CONDITIONING UNITS:

Note: - This specification covers the requirements of both capacity split air-conditioning unit, only the relevant specifications of required unit shall be considered while carrying out the work. Rate is inclusive of including MS stand and Bracket for indoor and outdoor unit.

These specifications cover the technical requirement of Nominal Capacity 1.0 TR (12000 Btu/hr or 3.51 kW), 1.5 TR (Nominal cooling capacity 4500 Kcal./Hr./ 18000 Btu/hr or 5.27 kW), 2.0 TR (24000 Btu/hr or 7.03 kW), & 2.5 TR (30000 Btu/hr or 8.77 kW) & 3 TR Capacity (Nominal cooling capacity 9000 Kcal./Hr or 2 Nos. x 36000 Btu/hr or 10.53 kW) split air-conditioning unit with their associated work. The unit shall be suitable for air throw (minimum) 6 meter from Air-conditioning unit.

Energy Performance Standards for Split Air Conditioners- Min. 2 Stars and above.

The 1.0 TR/ 1.5 TR/ 2.0 TR/ 2.5 TR/ 3.0 TR split air-conditioning unit shall have air cooled condenser. The unit shall comprise of 1 No. of 1.0 TR/ 1.5 TR/ 2.0 TR/ 2.5 TR/ 3.0 TR capacity outdoor unit (condensing unit) working in conjunction with 1 No. of indoor unit (evaporator unit) of 1.0 TR/ 1.5 TR/ 2.0 TR/ 2.5 TR/ 3.0 TR capacity capable of performing cooling, dehumidifying, air circulation and filtering functions respectively. The unit shall be suitable for coastal area. The unit shall be provided with suitable size electrical wiring/cabbling of required length as per site requirements.

Cabinet Construction:-

The cabinet for the indoor unit (evaporator unit) and outdoor unit (condenser unit) shall be made out of galvanized steel sheet of heavy gauge (of at least 1.0 mm thick) and aluminium alloy sheet (of at least 1.2 mm thick) and shall be provided with stiffeners for robust construction. Metal part shall have a stove enamelled finish preceded by primer paint, phosphating etc. Alternate method of corrosion

TECHNICAL SPECIFICATIONS M&E

protection like plastic powder coating, electrostatic painting is also acceptable in lieu of stove-enamelled finish. The unit shall be insulated acoustically.

(i) Outdoor Unit for 1.0 TR/ 1.5 TR/ 2.0 TR Split Air-Conditioning unit:-

The outdoor unit shall comprise of 1 Nos. of hermetically sealed type rotary compressor, having capacity of 1.0 TR/ 1.5 TR/ 2.0 TR each. Operation on refrigerant R-407c/ R-410A or environmental friendly latest refrigerant with suitable rated electric motor operating on 230 V \pm 10%, 50 hertz, single phase, A.C. supply and shall be equipped with over load protection. These shall be mounted on resilient mounting for quiet operation. The condenser shall be 1.0 TR/1.5 TR/ 2.0 TR single circuits for compressor. The fan for cooling condenser shall be propeller type and driven by High Efficiency EFF-1, TEFC squirrel cage induction motor.

(ii) Indoor Unit for 1.0 TR/ 1.5 TR/ 2.0 TR Split Air- Conditioning unit:-

1.0 TR/1.5 TR/ 2.0 TR capacity indoor units shall be suitable to be installed on wall/ suspended from ceiling/ floor mounted and shall have motorized oscillating supply air louvers. The unit shall have sensor and timer, equipped with full function remote control. The fan / blower shall comprise of centrifugal type, driven by High Efficiency EFF-1, TEFC squirrel cage induction motor, to give smooth and undistributed flow of air, low noise level and high air movement. The fan speed shall have multi speed setting and auto-mode for cooling and better temperature control. The cost of metal bracket for installation of I.D. unit are included in supply cost, hence no separate payment will be made for bracket. The filter pad provided shall be washable and of reputed make readily available in the market and shall be easy for maintenance.

(iii) Nominal Capacity 2.5/ 3 TR Mega Split AC (1 indoor unit of 2.5/ 3 TR each & 1 outdoor unit of 2.5/ 3 TR)

The outdoor unit shall comprise of hermetically sealed type rotary compressors, having capacity of 2.5/ 3 TR each. Operation on refrigerant R-407c/ R-410A or environmental friendly latest refrigerant with suitable rated electric motor operating on 230 V, \pm 10%, 50 hertz, three phase, A.C. supply and shall be equipped with over load protection. These shall be mounted on resilient mounting for quiet operation. The condenser shall be 2.5/ 3 ton capacity. The fan for cooling condenser shall be propeller type and driven by High Efficiency EFF-1, TEFC squirrel cage induction. 2.5/ 3 TR capacity indoor unit shall be suitable to be installed on wall/ suspended from ceiling/ floor mounted and shall have motorized oscillating supply air louvers. The unit shall have sensor and timer equipped with full function remote control. The fan / blower shall comprise of centrifugal type, driven by High Efficiency EFF-1, TEFC squirrel cage induction motor, to give smooth and undistributed flow of air, low noise level and high air movement. The fan speed shall have multi speed setting and auto-mode for cooling and better temperature control.

Installation of Indoor and Outdoor Units:-

TECHNICAL SPECIFICATIONS M&E

Following works falls within the scope of installation:

Mounting /fitting Indoor & outdoor units at their respective locations.

- (i) The outdoor unit shall be installed on M. S. Angle Iron stand and M.S. bracket as specified in TS.
- (ii) The indoor unit shall be fixed on wall/ suspended from ceiling/ floor mounted as specified in technical specification. The cost of M.S. bracket for I.D. unit shall be inclusive in the unit cost & No separate extra payment will be made for the above.
- (iii) Laying refrigeration piping of 5 meter and cabling, earth continuity conductor of 5 meter length & connecting both the units after drilling holes /hole in the wall.
- (iv) Insulating the suction pipe with expanded polyethylene foam Class 'O' closed cell nitrile rubber tubing.
- (v) Laying insulated drain pipe to terminate the condensate water from indoor unit to nearby waste water collection/ distribution facility or to the drain point as shown on site by the site engineer.
- (vi) Nitrogen Flushing and vacuum testing the system.
- (vii) Pressurization and Leak testing entire system.
- (viii) Charging refrigerant Gas in the unit.

Refrigerant Piping / Cabling & Earth continuity conductor & Drain Piping to be Supplied with each unit. i. e. (5 Meter insulated refrigerant piping, 5 Meter Cabling, 5 Meter Earth continuity conductor & 5 Meter insulated drain pipe)

Refrigerant Piping:

- (i) The supply and return refrigerant copper pipes and fittings shall be of appropriate size and gauge.
- (ii) The refrigerant piping shall be laid from outdoor to indoor units. The thickness of copper tubing shall not be less than 0.80 mm.
- (iii) The copper tubing as far as possible shall be in one complete piece.
- (iv) The interior of the piping shall be thoroughly scrubbed and cleaned to remove every trace of dirt, deposits and scale joints in pipes should be sweated or brazed and perfectly leak proof. The piping shall be provided with perfect bends.
- (v) The bends so provided shall be aesthetic in look.
- (vi) The pipe work shall be well supported and secured at interval of not more than 4 (four) feet and clamped in position to obviate any strain on joints.
- (vii) The suction refrigerant tubing shall be insulated by Class 'O' closed cell nitrile rubber tubing.
- (viii) Wherever refrigerant pipes cross the wall/ceiling, a PVC pipe sleeve of adequate size shall be provided. The gap between PVC sleeve & refrigerant piping shall be filled up with fire rated insulating material & then make the surface to original level of wall.

TECHNICAL SPECIFICATIONS M&E

Drain Piping:

The drain point outlet of each of the indoor units shall be connected with 1" diameter P.V.C rigid pipe with fittings and the pipe shall be laid along the wall / panel to the drain point as shown on site by the site engineer.

P.V.C. drain piping shall be supported on wall / panels by means of G.I. Saddle. The inter connection between drain point of indoor unit and P.V.C. drain pipe shall be made using siphon connection. The drain piping shall be insulated by expanded polythene foam Class 'O' closed cell nitrile rubber tubing.

Cabling and Earthing:

- (i) The PVC insulated copper cable of adequate size for indoor and outdoor unit and up to main switch shall be done in approved manner.
- (ii) Cable shall be fitted on wall / ceiling by means of G.I. spacers & G.I. saddle or G.I. clamps of suitable size.
- (iii) The cable shall be laid in one-piece length without joints.
- (iv) A.C. units shall be earthed by a copper earth continuity conductor of adequate size. The earth continuity conductor shall be run along the route of cable as far as possible.
- (v) All metal parts of equipment and framed structure shall be duly earthed by means of earthing terminations & connections in approved manner.

Providing & fixing of boxing for covering refrigerant piping, cabling:

The refrigerant piping and the electrical wiring from indoor to outdoor shall be suitably (to ensure against physical damage) covered with PVC/ aluminium powder coated boxing/ cover.

Providing & fixing of platform and MS railing:

Providing & fixing of platform and M.S. Railing for Outdoor units of Split AC to facilitate smooth access to technician to safely carry out maintenance. Platform shall be of 40 x 40 x 5 mm and 25 X 25 X 5 mm MS angle and accessories for fixing railing like fasteners etc. with epoxy painting.

Providing & fixing of m. S. Cage / enclosure for protection of window a.c. units & split a.c. unit:

The M.S. Cage/Enclosure shall be provided to the window model / outdoor unit of split air conditioning units for protection, made of M.S. angle iron of size 25 mm x 25 mm x 5 mm as stiffeners & middle supporting flat bars of size 25 mm x 3 mm (The gap between two flat bars shall be 100 mm) to cover entire a. c. AC unit.

The cage / enclosure shall be fixed to wall with suitable sized anchor fastener. To avoid vibration and metal-to-metal contact, a serrated rubber pads shall be provided between the base of the unit and M.S. Cage/Enclosure, along with locking arrangement & shall be painted in approved manner.

TECHNICAL SPECIFICATIONS M&E

The rates for M. S. Cage / Enclosure shall be same for 1.0 TR, 1.5 TR & 2.0 TR Split A.C. units.

The rates for M. S. Cage / Enclosure for 2.5 TR/ 3 TR Split A.C. units shall be separate.

Providing & fixing of rain protection cowl / weather shed for window & split a.c units:

The window model / outdoor unit of split A.C. unit shall be provided with cowl / Weather shed on its top at suitable height to prevent damage / deterioration of the unit and to protect it from direct sun rays. The cowl / weather shed shall be made up of 18 gauge G.S.S. sheet & shall be fitted to the unit / above unit with bracket made of galvanized / M.S. angle iron of size not less than 25 mm x 25 mm. X 3 mm & M.S. flat of size 25 mm. X 3 mm thick with necessary painting of high Solar Reflective Index (SRI) value or as per approved manner.

Drain Pump for AC units:-

Drain pump for AC unit shall be working on single phase supply and able to lift water upto 1.2 m height at single point, after that drain shall follow route with gravity. It should be easily serviceable and shall have filter net to protect dust entry into drain pipes avoiding any chances of choke-up in pipes.

Ancillary Work:

The ancillary work comprises of breaking, making, opening, grouting for mounting stand, air conditioning unit, refrigerant piping, electrical cabling, drain pipe and making the same as good as original surface.

Paint and Finish:

Metal work such as angle frames, bracket etc. shall be properly cleaned degreased pickled phosphated and applied with one coat of anti-corrosive red oxide and 2 coats of synthetic enamelled paint of approved make and shade. If the surrounding atmosphere is corrosive, the finishing paint shall be corrosion resistant for the type of atmosphere. This item shall be included in the above work, as no separate payment to this effect will be made.

Inspection & Testing:

Inspection & testing of A.C. units & accessories shall be carried out as specified or permitted in the relevant standard, unless otherwise specified and shall be carried out as specified in GS-5.1 i.e. (Inspection & Tests) for Air conditioning work.



SPLIT AIR CONDITIONING UNITS

3) CASSETTE TYPE A/C UNIT

Scope

i. The Scope of this section comprises the Supply, Ejection, Testing and Commissioning of Cassette type Air conditioning units, conforming to these Specifications and as per the Ratings.

ii. The Cassette type AC Unit shall comprise of indoor and outdoor units. The unit shall be provided with energy efficient inverter scroll compressor suitable for R-407/ R410/ R-32 refrigerant or other eco friendly refrigerant with controls, control panel, cooling coil, condensing unit, control wiring, insulated refrigerant piping, drain piping & low noise type design.

iii. The outdoor (condensing unit) shall be of Corrosion Resistant Galvanized powder coated or equivalent and shall be installed on suitable vibration isolators. Cooling fans shall have protective metal frame.

iv. The Cassette units shall be ceiling suspended, suitable for Modular ceiling. This Unit shall comprise of cooling coil having 2/3/4 rows deep with 12 to 13 fins per inch.

v. The unit shall comprise of aerodynamically designed diffuser Turbo fan motor shall have 3 speed arrangement & having three dimensional impeller & diffuser for controlling current flow inside the unit, into a single-bodies element, external static pressure shall be between 20 Pa to 78 Pa.'

vi. The unit shall have multi-flow system with wide air distribution without increasing wind speed & auto swing arrangement.

vii. Cassette Unit should comprise high lift drain water lift-up mechanism.

viii. The Unit comprise of Pre-filter and Fresh air intake arrangement. The filters shall be easily removable and cleanable.

ix. Sound level should not exceed more than 42 dBA for unit capacities up to and including 2 TR, while maximum 45 dBA for capacities above 2 TR and up to 4 TR at high speed.

x. The unit shall have cordless remote. In case of corded remote, the price shall be inclusive of necessary cabling within 1Mtr. of indoor unit.

Testing

TECHNICAL SPECIFICATIONS M&E

Units shall be tested or their design performance and test results ("TEST READING".) shall be furnished at the time of handing over of units.



CASSETTE TYPE A/C UNIT

4) Air cooled Ductable type AC unit:

The Air cooled ducted type A.C. unit shall be with hermetic type scroll compressor. Each unit shall be completely factory assembled, piped, wired and tested and shall comprise of scroll compressor, condenser fans, insulated cooler, air cooled condenser with microprocessor control panel. If multiple compressors are offered, they shall have independent refrigerant circuits. Also compressor shall be cut-off automatically under part load conditions.

The refrigerant used shall be R 410a or R 407 or R-134a or Eco friendly refrigerant.

The indoor unit shall comprise of fan, Cooling Coil, Filter and Expansion Valve.

The Outdoor unit shall be installed at the place decided by site engineer/concerned authority. The scope shall also include all supports for Indoor. The unit shall be selected for ambient conditions as specified. The unit shall be factory assembled and only the refrigerant piping carried out at site. The unit shall be insulated from inside with proper method of insulation. The unit shall be suitable to work on 415 V, 4 wire, 50 Hz AC supply.

- a) **CABINET**:-The shell shall be constructed out of corrosion resistance epoxy coated GI sheets of 18 SWG thick and the panel can be made out of 20 SWG CR epoxy coated sheet metal. All panels should be easily removable type for maintenance. Coil and blower section shall be internally lined with 12 mm thick resin bonded fiberglass and covered with nylon netting OR suitable similar material.
- b) **EVAPORATOR COIL**:-The cooling coil shall be made out of Copper/Aluminum tubes with external mechanically bonded Aluminums fins. The cooling coil shall have sufficient face area. A corrosion resistant drain pan shall be provided beneath the cooling coil, along with an outlet nozzle of not less than 40 mm dia. for drain connection. Washable type synthetic fabric media pre-filters of filtration efficiency of 90 % down to 5 microns shall be provided ahead of the cooling coil. The filter shall be easily removable for clearing purposes.
- c) **EVAPORATOR FAN**:-The evaporator fan shall be of centrifugal type with DIDW impeller designed for noise free operation. The fan and the drive shall be statically and dynamically balance. The fan shall be either directly driven OR belt driven by a suitably rated TEFC squirrel cage motor rated for 415 V, 3 phase, 50 Hz power

TECHNICAL SPECIFICATIONS M&E

supply. The motor shall be factory wired and brought out to a terminal block mounted on the outside of the unit, to facilitate easy wiring at site. The fan shall be quiet in operation and noise should be within permissible limit. The static head generated shall be sufficient for flow across the pre filters.

d) COMPRESSOR:-Compressors offered shall be hermetic scroll type, suitable for operating with R 410a or R 407 or R 134a or Eco friendly refrigerant. The motor shall be rated for 415 V, 3 phase, 50 Hz power supply and should be capable of operating under +/- 10 % fluctuations in the supply voltage. If multiple compressors are offered for the specified split units, then each of the compressors shall be of equal capacity. Moreover an electronic temperature controller shall be provided which shall automatically and progressively trip the compressors under partial load condition. The compressors shall be housed in the air-cooled condensing unit. The compressors shall be mounted on spring vibration isolators.

e) CONTROL PANEL:-The units shall be supplied with microprocessor based control system. The system shall have digital display of the set point temperature. The following safety features shall be provided and the same shall have LED indications.

- Under voltage/Over voltage trip.
- Phase Failure/Phase reversal trip.
- High Pressure trip
- Fan fails indication

The following mode selection shall be provided

- (ix) Fan Mode.
- (x) Cool Mode

The panel shall allow temperature set point adjustment.

f) AIR COOLED CONDENSING UNIT:-The condensing unit shall be designed for outdoor installation and hence be of weatherproof construction. This shall house the Compressor(s) and the air cooled condenser. The condenser should be designed to match the capacity of the air-conditioner even during worst operating conditions. Air-cooled condenser coils shall be with copper /aluminum tubes & aluminum fins. It shall also house the directly driven axial flow fan. The condenser coil shall be of Copper tubes and mechanically bonded aluminum fins. The coil should be adequately sized to handle the design head rejection and size provides sub cooling. The coil should be designed to work under a peak ambient temperature of 41 Deg. C.

g) LOCATION OF UNIT:- The outdoor units shall be installed as per instruction of Engineer/concerned authority at convenient site. The outlet of the units shall be connected to indoor units through ducting of sufficient size & in consultation with the site Engineer. The outdoor units shall be placed ground with Neoprene serrated rubber pads to ensure vibration free operation.

h) PRE-COMMISSIONING TEST:-The following tests/checks are generally required to be carried out before commissioning of the plants. The site engineer shall have right to waive certain tests as per site conditions.

TECHNICAL SPECIFICATIONS M&E

- Check supply voltage, it should not be less than the stated voltage of the compressor motor.
- Check power and control circuit.
- Ensure that all electrical equipments are effectively earthed.
- Check the operation of over load and low volt release in the motor starters.
- Check all terminals and ensure they are all fully tight.
- Check operation of all protection devices.
- Thermostat should be set to maintain the temperature at desired level.
- Record W.B. and D.B.

Operate the plant continuously for 12 (twelve) hours; after which all points referred to above should be once again being checked. In addition, check all parts of the refrigerant piping system for leak detections.

- i) **TESTING:-** All routine tests as per standard practice shall be carried out. The tests shall be taken in presence of the Municipal Engineers/ concerned authority over a period of three days. All parameters like suction pressure, discharge pressure, temperature, humidity, power etc. shall be tested along with the entire air conditioning system.

5) AIR COOLED PACKAGE AIRCONDITIONER UNITS:

1. Scope

The Scope of this section comprises the Supply, Erection, Testing and Commissioning of Air cooled Package type AC units, conforming to these Specifications and as per the Ratings.

2. **Broad Specifications**

- (i) The Package AC Unit Package shall comprise of Indoor and outdoor units. Package unit shall be comprising of energy efficient Scroll compressor with controls such as thermal protector, HP/LP cut-outs, Pressure relief valve, DX coil with finned copper tubes (Evaporator), Low noise design Centrifugal Fan unit with high Efficiency EEF-1 motor & belt drive package; fan unit shall have proper insulated and leak proof condensate base connected to drain piping with suitable trap and laid up to nearest drain point designed to ensure zero leakage; the fan assembly shall be dynamically balance for low vibration and low noise type design. The units shall have integral refrigerant copper piping within compressor, Throttling Device and evaporator and accessories such as refrigerant shutoff valves at compressor / compressors and liquid refrigerant outlet if required & filter dryer.
- (ii) The outdoor (condensing unit) shall be of Corrosion resistant Galvanized powder coated or equivalent paint Sheet steel low vibration assembly installed on suitable vibration isolators and comprising of finned tube air cooled condenser and condenser fan unit. The units shall have integral refrigerant copper piping within condenser and accessories such as refrigerant shutoff valves and liquid refrigerant outlet. Cooling fans shall have protective metal frame.
- (iii) The microprocessor based Package AC unit shall be complete with Motor Starters, Microprocessor based Control Panel, Power and Control wiring & earthing.

3. **Packaged AC Unit**

The Package Indoor Unit is of sectionalized construction of corrosion resistant heavy gauge steel, finished with enamel paint and consisting of fan section, coil and filter section, and insulated drain pan and Compressor (Twin or Single as per Unit rating) Section.

The unit shall be internally lined with fiber glass of adequate thickness for thermal insulation and acoustic lining. If the insulation is in damaged condition during transit or otherwise, vendor to repair with either PU foam / Phenolic foam with suitable finish.

4. **Compressor**

Compressor shall be energy saving Scroll type Compressor (Twin or Single as per Unit rating) suitable for R-407c/ R410A/ R-134a refrigerant or other eco friendly refrigerant and shall be complete with required accessories such as pipe flanges, suction strainers, muffler, suction and discharge pressure gauges, oil heaters, oil pressure gauge, HP - LP cut-out, OP cut-out, pressure relief valve, overload for motor protection etc. Compressor shall be suitable to operate on 3 phase, 400/440 volts, 50 cycles AC supply and shall be designed to withstand voltage fluctuation of 15 %. The compressor shall be installed on vibration isolating resilient material, so as to ensure operation with the minimum noise and vibrations.

TECHNICAL SPECIFICATIONS M&E

5. **Cooling Coils**

Cooling coils shall be of fin and tube type having aluminium fins firmly bonded to copper tubes assembled in G.I. Frame. Coil shall be fitted with equalizing copper distributor to ensure that each coil circuit receives equal amount of refrigerant. Face surface area of cooling coils should be adequate for the air quantity handled and air velocity across the coil shall not exceed as recommended for the application. Aluminium fins shall be corrugated and collared with mechanical bonding.

6. **Evaporator Fan**

Fan impellers and housing shall be fabricated with heavy gauge steel. Fan impeller shall be forward curved, multi blade type enclosed in housing and mounted on a common shaft. All rotating parts shall be statically & dynamically balanced. Vendor to check the condition of Fan at site accordingly prior to start-up and commissioning.

7. **Evaporator Motor**

Fan motor shall be squirrel cage totally enclosed fan cooled (TEFC) type of adequate capacity suitable to operate on three phases, 400/440 volts, 50 cycles AC supply. Fan motor shall be mounted on an adjustable vibration-isolating base located in the casing of the unit. Fan shall be driven directly or through standard V - belts with belt guard. The belt drive package shall be adequately designed to meet the desired design CFM. Starter (DOL) and independent SPP shall be provided.

8. **Filter**

Each filter shall be High Density Polyethylene (HDPE) washable or metallic type with adequate thickness. Filter holding frame shall be designed such that leakage of air can be avoided. Velocity across filter shall not exceed design requirement.

9. **Air Cooled Condensing Unit**

- i. Casing: Condenser casing shall be made of corrosion resistant heavy gauge steel finished with enamel paint. If specified it shall be epoxy painted or powder coated.
- ii. Condenser coil: Condenser coil shall be of copper tubes having aluminium fins firmly bonded to tubes. Condenser coil shall be three rows deep. Each coil shall be factory tested. The coil shall have integral sub-cooling circuit. The air volume and coil face area shall be adequate for the capacity. Air velocity across the coil shall not exceed design requirements. If specified the coil shall be made out of tinned copper tubes and tinned copper fins. The condenser shall serve as liquid receiver for the refrigerant circuit.
- iii. The refrigerant circuit shall include thermo-static expansion valve and suction gas strainer. The work shall include provision of suction line insulation as per manufacturer standards.

TECHNICAL SPECIFICATIONS M&E

- iv. Condenser Cooling Fans: Fans shall be propeller axial type. One or more fans shall be provided for the required capacity.
- v. Condenser Cooling Fan Motor: Fan motor shall be TEFC, squirrel cage, induction motor suitable to operate on 3 phase, 50 cycles, 400/440 volts, 50 cycles, AC supply and provided with pulley, V- belt set or direct drive, flexible coupling with guards. Motor shall have class "F" insulation and shall be provided with weather protection.
- vi. Connections with valves: Refrigerant gas inlet connection, Liquid refrigerant outlet connection. Pressure relief valve, drain valve and air-vent valve.
- vii. Installation: Entire air-cooled condensing unit assembly shall be installed on MS channel stand with vibration isolators and at the place as indicated in drawings. If specified spring isolator and Hot dip galvanized / epoxy painted structure shall be provided. Entire Evaporator assembly shall be supported through MS rods of required diameter (mm) and suspended from the slab and at the place as indicated in drawings.
- viii. Painting: All the equipment including base frame etc. shall be factory painted with two coats of a suitable enamel paint of approved colour over a rust resistant primer. Paint that have become marred during shipment or erection shall be cleaned off with mineral spirit, wire brushed and spot primed over the affected areas, then coated with enamel paint to match the colour shade of original painted surface.
- ix. Testing: All routine tests as per standard practice shall be carried out. The tests shall be taken in presence of the Municipal Engineers/ concerned authority over a period of three days. All parameters like suction pressure, discharge pressure, temperature, humidity, power etc. shall be tested along with the entire air conditioning system.

TECHNICAL SPECIFICATIONS M&E

10. **Microprocessor Based Control Panel**

The microprocessor based control panel shall be with digital display showing trip and status conditions. It shall have a membrane/alternate design user-friendly key board for set-point control. It shall as a minimum provide following features:

- (i) Auto-switch off of the condenser fan when the compressor cuts off for power saving.
- (ii) Single button start and stop flexibility for the user; the sequences for start and stop shall be taken care by the controller.
- (iii) Integrated electronic temperature sensor for precise measurement and consequent control of return air temperature.
- (iv) Compressor start-up delay timer for compressor protection and increase operational life.
- (v) Auto-restart on power restoration – optional.

11. **Testing**

Units shall be tested or their design performance and test results (“TEST READING”.) shall be furnished at the time of handing over of units.



Air cooled Ductable type AC unit:

6) **WATER COOLED PACKAGED AC PLANT-**

The packaged type water-cooled air-conditioning unit shall be of cabinet type construction of heavy gauge C.R.C.A. sheet attractively finished in enamel or quality hammer tone paint or powder coating and fully insulated thermally and acoustically.

The packaged plants shall be provided with a removable type front panel for easy access in to the unit and shall comprise of compressor of semi hermetically sealed / scroll type, fully protected from overloading and burn out by external and internal overloads with high and low pressure cutouts, pressure switch with its cable and temperature controls. These shall be incorporated in a microprocessor based controller. Water cooled condenser of shell and tube type with shell of steel and the seamless tubes of copper with integral fins, with relief valve on condenser receiver, cooling coils of copper tubes, hydraulically expanded into aluminum plate fins to provide efficient heat transfer, low by pass factor, condensate drip pan of GI sheet

TECHNICAL SPECIFICATIONS M&E

steel, insulated with tar felt stucked with bitumen or glass wool sheets, expansion valve, liquid line strainer.

A centrifugal blower with totally enclosed fan cooled squirrel cage induction motor suitable to work on 400/440 A.C. supply (in built) starter (suitable for compressor motor of the packaged unit complete with bimetal thermal overload relay, single phase preventer & 'ON/OFF' push buttons and cleanable 20 micron H.D.P.E. filters. The packaged plants shall be complete with first charge of R-407 refrigerant and oil. Necessary preventive measures shall be incorporated to avoid sweating on the outer panels of the unit during operation. The controller system proposed to be installed in the package unit shall be of microprocessor based with integrated control circuitry & logically interlock functions to control temperature & pressure, etc. All the required control cables as per site conditions shall be provided. The new water cooled packaged unit shall be installed in the existing plant rooms in consultation with the site Engineer. This unit will be placed on cement concrete foundation of suitable height along with serrated rubber pads to ensure vibration free operation.

Water-cooled packaged unit has single or multiple hermetic compressors with independent refrigerant circuits. Each refrigerant circuit consists of a high efficiency condenser, a sealed strainer and capillary tubes which has been leak tested, evacuated and fully charged with refrigerant R-407/ R410/ R-134a refrigerant or other eco friendly refrigerant at the factory

High Efficiency Hermetic Compliant Scroll Compressor- Quiet operation. The compressor shall be with excellent reliability with 70% fewer moving parts than comparably sized reciprocating compressors. Greater capability at handling liquid and debris in the system. High efficiency performance.

Enhanced Copper Tubes Condenser - Extra-high efficiency is attained by special designed shell-and-tube condenser with "T" groove copper tube surfaces for superior refrigerant-water heat transfer.

Anti-Corrosion Unit Casing- Unit casing is constructed of electro-galvanized steel sheet. Casing surface is finished with epoxy polyester powder coating & quiet in operation. Each unit is divided into separate compartments such that compressor noise is kept away from the supply air stream. Internal insulation of 1/2 inch thick fiberglass and double blowers design further reduce noise level. Each unit is leak-tested, evacuated, fully charged with refrigerant and run tested as per standard norms.

Installation and Connection- Avoid installing the unit in damp and corrosive environment. Install the unit on a level concrete groundwork. Space should be ventilated and easy to maintenance. Please refer to the Dimension Illustration for minimum installation. A rubber should be placed between the concrete groundwork and the unit to avoid vibration and noise. Avoid direct contact between unit/connecting pipe and wall/mounting ceiling.

Water Pipe Connection - All installation for piping must comply with local laws and regulations. Bends and vertical spans should be as less as possible. To maintain a constant condensing pressure and temperature, a 3-way valve can be used to

TECHNICAL SPECIFICATIONS M&E

accommodate the water flow. The valve has to be mounted to maintain that the water inlet temperature is 16°C at the condenser. To prevent water temperature from dropping too low, a temperature switch (27°C recommended) can be used to control the startup/shutdown of fan in the cooling tower. The condensate drainpipe is connected to the drain pan of the evaporator (The drain pan is attached to the bottom of the unit for emergency discharge only).

Pre-Commissioning Test:-The following tests/checks are generally required to be carried out before commissioning of the plants. The site engineer shall have right to waive certain tests as per site conditions.

- Check supply voltage, it should not be less than the stated voltage of the compressor motor.
- Check power and control circuit.
- Ensure that all electrical equipments are effectively earthed.
- Check the operation of over load and low volt release in the motor starters.
- Check all terminals and ensure they are all fully tight.
- Check operation of all protection devices.
- Thermostat should be set to maintain the temperature at desired level.
- Record W.B. and D.B.

Operate the plant continuously for 12 (twelve) hours; after which all points referred to above should be once again be checked. In addition, check all parts of the refrigerant piping system for leak detections.

Testing: - All routine tests as per standard practice shall be carried out. The tests shall be taken in presence of the Municipal Engineers/concern authority over a period of three days. All parameters like suction pressure, discharge pressure, temperature, humidity, power etc. shall be tested along with the entire air conditioning system.



WATER COOLED PACKAGED AC PLANT

7) VRF/ VRV VARIABLE REFRIGERANT FLOW/ VOLUME SYSTEM EQUIPMENT

a) Outdoor Units

Outdoor units of the VRF/VRV system shall be compact air cooled type. All the compressors of the outdoor units must be hermetically sealed scroll type. Each module of outdoor unit must have at least 1 inverter compressor, suitable to operate at varying heat load proportional to indoor requirement. The outdoor units shall be suitable to operate within an ambient temperature range of – 5 Deg C to 43 Deg C, in

TECHNICAL SPECIFICATIONS M&E

cooling mode & 20 Deg C to 15 Deg C in heating mode. The outdoor units must be suitable for up to 150 m refrigerant piping between outdoor unit & the farthest indoor units, total piping of 300 m for all the indoor units. Allowable level difference between outdoor unit & indoor units shall be 50 m in case of outdoor unit on top & 40 m in case of outdoor unit at bottom. Allowable level difference between various indoor units connected to one outdoor unit shall be up to 15 m. Back up operation, in case of failure of one of the compressors of outdoor unit, for single module outdoor units or failure of one of the modules in case of multiple module outdoor units shall be possible. The VRF/VRV outdoor unit shall always be supplying at least 33% of back up operation, of the full load capacity. The outdoor unit shall employ system of equal run time for all the compressors, inverter or on / off type, within each outdoor unit – Single Module or Multi Module. The outdoor units shall be suitable to operate within an ambient temperature range of – 5 Deg C to 43 Deg C, in cooling mode. Air cooled condenser shall have Axial Flow, upward throw fan, directly coupled to fan motors with minimum IP 55 protection. The outdoor unit condenser fan shall be able to develop external static pressure up to 7.5 mm of H₂O. The outdoor unit should be with canopy at top to protect from heavy rain. Starter for the Outdoor Unit compressor shall be “Direct on Line” type. Inverter compressor of the unit shall start first & at the minimum frequency, to reduce the inrush current during starting. Specification for starter panels furnished in below electrical section. Refrigerant control in the outdoor unit shall be through Electronic Expansion Valve. Complete refrigerant circuit, oil balancing/ equalizing circuit shall be factory assembled & tested. Noise level of outdoor units shall not exceed 65 dB (A) at a distance of 1.5 m from the unit.

Outdoor units shall be complete with following safety devices:

- High pressure switch
- Fan driver overload protector
- Over current relay
- Inverter Overload Protector
- Fusible Plug
- Short Circuit Protection

Unit shall be supplied with

- Installation manual
- Operation Manual
- Connection Pipes
- Clamps

VRF/VRV SYSTEM

The Variable Refrigerant Flow (VRF / VRV) System should be air cooled, split type air conditioning system consisting of condensing units connected to multiple indoor units, having the capability of individual set point control. The system should have the ability to connect each condensing unit to required indoor units of different types and capacities on one refrigerant circuit. The system is to be of the cooling type. Each Condensing unit should incorporate at least one inverter based scroll compressor & other / others fixed scroll compressors, to obtain 10% to 100% step less capacity

TECHNICAL SPECIFICATIONS M&E

control for enhanced Power saving. The VRF/VRV system shall provide stable, trouble free & safe operation, with flexibility of operating desired indoor units. The outdoor units must be capable of delivering exact capacity proportional to the number of indoor units switched on & the heat load in the air conditioned area. The proportional operation shall be achieved by varying speed of the compressor in the outdoor units. The entire system shall be controlled by a system controller. The system controller shall be able to control start / stop on time schedule and also provide common fault from the system. The system shall be BMS compatible.

Refrigerant

The Entire Condensing unit and Evaporating unit should be Factory assembled and tested. The units should come with an initial charge of refrigerant R410A / other equivalent eco friendly refrigerant. Any additional refrigerant is to be added at site.

Refrigerant Piping Distance Limits

To be capable of refrigerant piping runs up to 150m between the condensing unit and indoor units with 50m level difference without any oil traps or double risers. The Oil Equalizing line should be inside the Condensing unit, to avoid 'inverted' oil traps at site.

Condensing Units

They shall be fully weatherproofed, factory assembled and pre-wired with all necessary electronic and refrigerant controls. The casing shall be from mild steel panels coated with a baked enamel finish. Provide the condenser coil fins with a corrosion resistant finish. The Condensing Units shall incorporate suitable compressors in condensing units with at least one inverter scroll compressor and other two fixed speed scroll compressors. The design shall be modular type allowing for side by side installation of the condensing Units.

Fan Motor Speed Control:

The condensing unit fan motors to have at least two speed operations to maintain constant head pressure control in all ambient temperatures and modes of operation.

Compressors

The compressor shall be highly efficient at least one inverter based scroll compressor. The compressors shall have electronic controls, capable of loading and unloading to follow the variations on cooling using the latest axial compliant sealing technology. The microprocessor panel should incorporate control for precise monitoring of status of the system. Each compressor shall have in-built overloads, HP and LP controllers and mounted on vibration isolators.

Heat Exchanger

The heat exchanger shall be constructed from seamless copper tubes mechanically bonded to aluminium fins to form a cross fin coil. The aluminium fins shall be treated with an anti-corrosion film.

TECHNICAL SPECIFICATIONS M&E

Refrigerant Circuit

The refrigerant circuit shall be complete with condensing unit with refrigeration compressors, motors, fans, condenser coils, electronic expansion valve, solenoid valves, 4-way valve, distribution headers, capillaries, filters, shut down valves, service ports, receivers and accumulators and all other components which are essential for safe and satisfactory operation.

Safety Devices

Provide the following safety devices as a part of the outdoor unit: High pressure switch, fuses, crank case heater, fusible plug, over current protector.

Selection Switches

Fit the condensing unit printed circuit board (PCB) with selection switches for the length of pipe work, emergency operation switches and service mode switches, together with LED indications for operation / fault indication.

b) INDOOR UNITS

i) Ductable Type Indoor Unit

The IDU shall include pre filter, fan section & DX coil section. The unit shall be equipped with an electronic expansion valve, which can communicate with the VRF controller in the condensing unit. The housing of unit shall be light weight & powder coated galvanized steel. The unit shall have high static fan for Ductable arrangement. The address of the indoor unit shall be set automatically in case of individual and group control. In case of centralized control, it shall be set by liquid crystal display remote controller. The fan shall be dual suction, aerodynamically designed turbo, multi blade type, statically & dynamically balanced to ensure low noise and vibration free operation of the system. The fan shall be direct driven type, mounted directly on motor shaft having supported from housing. The cooling coil shall be made out of seamless copper tubes and have continuous aluminum fins. The fins shall be spaced by collars forming an integral part. The tubes shall be staggered in the direction of airflow. The tubes shall be hydraulically/ mechanically expanded for minimum thermal contact resistance with fins. Unit shall have cleanable type. The filter shall be easily serviceable. Each unit shall be provided with microprocessor thermostat for cooling or cooling and heating. Each unit shall be with wired LCD type remote controller. The remote controller shall memorize the latest malfunction code for easy maintenance. The controller shall be able to change fan speed and angle of swing flap individually as per requirement. The unit shall be supplied with Wireless remote.

ii) Concealed Split Type Indoor Units

The IDU shall include pre filter, fan section & DX coil section. The unit shall be equipped with an electronic expansion valve, which can communicate with the VRF controller in the condensing unit. The housing of unit shall be light weight &

TECHNICAL SPECIFICATIONS M&E

powder coated galvanized steel. The address of the indoor unit shall be set automatically in case of individual and group control. In case of centralized control, it shall be set by liquid crystal display remote controller. The fan shall be dual suction, aerodynamically designed turbo, multi blade type, statically & dynamically balanced to ensure low noise and vibration free operation of the system. The fan shall be direct driven type, mounted directly on motor shaft having supported from housing. The cooling coil shall be made out of seamless copper tubes and have continuous aluminum fins. The fins shall be spaced by collars forming an integral part. The tubes shall be staggered in the direction of airflow. The tubes shall be hydraulically/ mechanically expanded for minimum thermal contact resistance with fins. Unit shall have cleanable type. The filter shall be easily serviceable. Each unit shall be provided with microprocessor thermostat for cooling or cooling and heating. Each unit shall be with wired LCD type remote controller. The remote controller shall memorize the latest malfunction code for easy maintenance. The controller shall be able to change fan speed and angle of swing flap individually as per requirement. The unit shall be supplied with Wireless remote.

iii) **Cassette Type Indoor Units**

The indoor units shall be ceiling mounted cassette type with multi flow. It shall have electronic expansion control valve which controls refrigerant flow rate in respond to load variations of the room, i.e. shall communicate with the VRF controller in the condensing unit. The fan shall be of the dual suction multi blade type statically and dynamically balanced to ensure low noise and vibration free operation. The cooling coil shall be made out of seamless copper tubes and have continuous aluminum fins. For ceiling mounted cassette unit, it shall include pre filter fan section and DX coil section. The housing of the unit shall be powder coated galvanized steel. The body shall be light in weight and shall be able to suspend in four corners. The unit shall have external attractive panel for supply and return air. The unit shall have four-way supply air grille on sides and return air grille in the centre. Each unit shall be provided with a high lift drain pump. The Ceiling Mounted Cassette type Indoor Unit shall be with decorative panel, compact cooling coil, electronic expansion valve, Multi speed fan motors, dynamically balanced blowers, provision for Fresh Air Intake, drain pump, synthetic washable media filter including insulation and suitable for operation on single phase AC supply & remote control operation including Wireless Remote Control. The unit shall be supplied with Wireless remote.

iv) **Hi-Wall Type Indoor Units**

The Hi- Wall Mounted type Indoor Unit shall be equipped with an electronic expansion valve, which can communicate with the VRF controller in the condensing unit. It shall be with compact cooling coil, Multi speed fan motors, dynamically balanced blowers, provision for synthetic washable media filter including insulation and suitable for operation on single phase AC supply & remote control operation including Wireless Remote Control. The unit shall be

TECHNICAL SPECIFICATIONS M&E

suitable for coastal area. The cabinet for the indoor unit shall be made out of heavy gauge galvanized steel sheet or aluminium alloy sheet and shall be provided with stiffeners for robust construction. Metal part shall have a stove enameled finish preceded by primer paint, phosphating etc. Alternate method of corrosion protection like plastic powder coating, electrostatic painting is also acceptable in lieu of stove-enameled finish.

c) AHU CONTROLLER / DISTRIBUTION KIT

The AHU Controller / distribution kit should be of suitable capacity for connecting multi VRF ODU to DX AHU as per desired load with a) built in auto restart function, c) with necessary electrical wiring & remote controller shall be provided.

d) CONTROL SYSTEM FOR VRV/VRF AIR CONDITIONING SYSTEM.

Wired/Wireless Remote Controller:

Wired/Wireless remote controller shall be supplied as specified in the "Bill of Quantities"

The controller must have large crystal display screen, which displays complete operating status.

The digital display must allow setting of temperature with 1 Deg C interval.

Remote shall be able to individually program by timer the respective times for operation start and stop for a period of 1 week.

Remote shall have 24 hrs. Clock function.

Programming can be enabled or disabled. Provide scheduling of start / stop and temperature limit – 5 settings per day.

Remote must be equipped with thermostat sensor in the remote controller that will make possible more comfortable room temperature control

The remote shall be able to monitor room temperature & preset temperature by microcomputer & can select cool/ heat operation mode automatically.

The remote must constantly monitor malfunctions in the system & must be equipped with a "self diagnosis function" that let know by a message immediately when a malfunction occurs.

Compact light receiving unit to be mounted into wall or ceiling shall be included in case of wireless remote controller if applicable.

Central Control system controller:

Central control system controller shall be supplied as specified in the "Bill of Quantities".

The System supplied must integrate with the VRF / VRV system.

The VRF / VRV system supplied must be provided with a control system, from the supplier of VRF / VRV equipments.

TECHNICAL SPECIFICATIONS M&E

The complete operation & monitoring of VRF / VRV air conditioning system shall be possible through the control system.

Following functions shall be possible

- Controlling indoor units
- Zone control
- Malfunction code display
- All the functions available with wired remote controller
- It should be possible to wire the remote to 1000m
- Remote start / stop of indoor units
- Mal function report.
- Colour LCD touch panel icon display
- Fault History up to 100 actions.
- Simple Interlock Function
- Fire Alarm System interface

Required hardware shall be suitable for operation between -10 Deg C to 50 Dg C & humidity range, of 0% to 98%, without condensation.

e) REFRIGERANT PIPE WORK / REFNET JOINTS

Refrigerant Pipe work

The scope of Refrigerant Piping work shall include Supply, installation, testing and commissioning all interconnecting pipe work between the condensing unit and the Indoor units. The refrigerant piping shall be out of hard / soft quality, pre-pressure tested, copper seamless pipe, of sizes as calculated to limit the pressure drop in the suction line and in the liquid line and hot gas line. The tenderer should ensure that the units are capable of delivering the rated capacity and meet the inside design conditions based on the locations of the indoor and outdoor units and also ensure that the air-conditioning units can perform, at the distances and elevation differences between the indoor and outdoor units. Refrigerant Copper piping shall be duly with insulated Nitrile Rubber Insulation (As per Specified with K Value of 0.027-0.029 K Cal/Hr. M Deg C at 0-16 Deg C) as follows

- 1/4 " (13mm thick Nitrile Rubber Insulation)
- 3/8" (13mm thick Nitrile Rubber Insulation)
- 1/2" (13mm thick Nitrile Rubber Insulation)
- 5/8" (13mm thick Nitrile Rubber Insulation)
- 3/4" (13mm thick Nitrile Rubber Insulation)
- 7/8" (13mm thick Nitrile Rubber Insulation)
- 1" (13mm thick Nitrile Rubber Insulation)
- 1 1/8" (19mm thick Nitrile Rubber Insulation)
- 1 1/4" (19mm thick Nitrile Rubber Insulation)

TECHNICAL SPECIFICATIONS M&E

- 1 3/8" (19mm thick Nitrile Rubber Insulation)
- 1 1/2" (19mm thick Nitrile Rubber Insulation)
- 1 5/8" (19mm thick Nitrile Rubber Insulation)
- 1 3/4" (19mm thick Nitrile Rubber Insulation)
- 1 7/8" (19mm thick Nitrile Rubber Insulation)
- 2" (19mm thick Nitrile Rubber Insulation)

Refrigeration piping will have to be taken in the piping rack / Support individually connecting to all indoor units for the respective floors. Refrigerant pipes should be supported on grooved wooden stripes suitable to accommodate the insulated refrigerant pipes. The piping should be clamped to these wooden strips using a 'C' clamps. Necessary supports, fittings, valves & ref. joints where ever required will be included. The distance between two supports should not be more than 5 ft. wherever the pipes are running on the floor or exposed to view should be covered with 18 G GI tray/ plastic tray. The piping shall be refrigerant quality seamless copper tube with brazed connections and with the appropriate Distribution joints and headers. The piping should be routed at site in such a manner, that brazed joints in the Ref. Piping are kept to a minimum. During brazing, pass dry nitrogen through the pipe work. For outdoor piping, the pipes, after insulation, should be covered with Woven Glass Cloth 125 gsm finished in U/V Treated, pigmented Epoxy for Outdoor Piping, as per relevant code. All refrigerant pipes shall be insulated with tubular elastomeric nitrile rubber of adequate thickness as per manufactures standards or ASHARE Guidelines or as per specifications.

Cleanliness of piping

All pipe work must be kept clean and free from contamination to prevent breakdown of the system. Seal all pipe ends and keep sealed until immediately prior to making a joint.

Pressure Testing

The piping shall be vacuum dehydrated immediately after installation of pipe work and prior to sealing of insulation joints and start up of equipment & pressure tested to 3,800kPa; held for a minimum of 24 hours & checked for leaks and repaired if necessary. Following this, the pipe work to be vacuum dehydrated to (-755 mmHg) and held for one to four hours depending on the pipe length.

Fixing Pipe work

Pipes shall be layed on GI cable tray of adequate size wherever necessary as per site requirement and supports shall be fixed at minimum of 2 meter centers with suitable saddling arrangement. Exposed Refrigerant pipes on the terrace shall be covered with openable GI Cable trays.

Joint Orientation

TECHNICAL SPECIFICATIONS M&E

The scope of Refnet joints work shall include Supply, installation, testing and commissioning of refnet joints on refrigerant pipeline.

The Distribution refrigeration pipe joints and headers shall be located in an appropriate orientation to enable correct distribution of refrigerant. The Distribution Joints should be factory insulated with pre-formed sections of EPDM / Equivalent. All the refrigerant joints shall be proprietary in nature from the main VRV/VRF supplier. It should have one inlet and two outlet connections, both for suction and liquid line of respective size of the refrigerant piping along with its insulation. The refrigerant joint should be designed and supplied by the supplier of VRF indoor and outdoor unit manufacturer.

8) CHILLED WATER FAN COIL UNITS 1.0/ 1.5/ 2/ 2.5/ 3 TR WITH CONTROLLER-

The unit shall be of sectionalized construction, consisting of Fan Section, Coil Section, and Filter section. The drain pan of the coil section as applicable. The fan section shall contain one or more centrifugal fans, the wheels being mounted on a common shaft and secured by hub assembly. Fan wheels and the shaft shall be statically and dynamically balanced. The fans shall be forward curved, double inlet, multi-blade type. The FCU Fan Motor shall be Three Speed and suitable for operating on 220 / 240 V, 50 Hz single phase AC Supply. The FCU's shall be supplied with required length of cable & cordless remote control.



CHILLED WATER FAN COIL UNITS

9) DX TYPE PRECISION AC UNITS

SITC of DX type Precision AC Unit. Unit shall be with remote controller, Fixed speed scroll compressor & EC Motor. Unit shall have backward curved plug fan, IP 54 motor, copper cooling coil, with heater and humidifier. The nominal capacity of unit shall be 18/26 TR as required working on return air, bottom discharge type, double skin side panels with insulation of 25 mm Rockwool, with eco-friendly refrigerant, washable HDPE filters.

10) TOWER AC UNITS

Tower AC shall be durable powder coated outer body. It shall have inner grooved copper and an anti-corrosive blue fin condenser for a highly efficient heat transfer. It shall have 3-phase scroll compressor and must be sturdy system design ensure a longer life & reliable. It must be easy to use and operate, must have LED display

TECHNICAL SPECIFICATIONS M&E

which shows settings and temperature. 2.0/ 3.0 TR Tower AC has a cooling capacity of 24000/ 36000 BTU/ Hour. Tower AC shall be along with dust filter which gives fresh and sanitized air. Tower AC must have air throw of up to 1062 CFM (+- 50CFM) & must have to reach every corner of the room for instant and efficient cooling. There shall have oscillating louvers which ensure an even distribution throughout the space. The tower AC should not exceed noise level more than 55 DB for unit. The refrigerant used shall be R 410a or R 407 or R-134a or Eco friendly refrigerant. The Outdoor unit shall be installed at the place decided by site.

Supply and fixing of M.S. stand & Bracket for fixing of indoor & outdoor of 2/3 TR Tower AC:-

The outdoor unit shall be installed on M. S. Angle Iron stand and bracket made of M.S. angle iron of size 40 mm x 40 mm. X 5 mm. as stiffener to withstand the load of outdoor unit, with platform at suitable level. The stand /brackets shall be fixed to wall with suitable sized anchor fastener. To avoid vibration and metal-to-metal contact, a serrated rubber pads shall be provided between the base of the unit and M.S. Stand. The A.C. unit shall be charged with refrigerant gas. The M. S. Angle Iron Stand and bracket shall be duly painted as specified. The indoor unit shall be fixed on wall by providing adequate strength of metal bracket to withstand the load of indoor unit permanently. No separate extra payment will be made for above. The frames/brackets shall be painted in approved manner.

SITC of refrigerant piping 3/4" & 3/8" for 3 TR Tower AC:-

Refrigerant Piping: (i) The supply and return refrigerant copper pipes and fittings shall be of appropriate size and gauge. (ii) The refrigerant piping shall be laid from outdoor to indoor units. The thickness of copper tubing shall not be less than 0.80 mm. (iii) The copper tubing as far as possible shall be in one complete piece. (iv) The interior of the piping shall be thoroughly scrubbed and cleaned to remove every trace of dirt, deposits and scale joints in pipes should be sweated or brazed and perfectly leak proof. The piping shall be provided with perfect bends. (v) The bends so provided shall be aesthetic in look. (vi) The pipe work shall be well supported and secured at interval of not more than 4 (four) feet and clamped in position to obviate any strain on joints. (vii) The suction refrigerant tubing shall be insulated by Class "O" closed cell nitrile rubber tubing. (viii) Wherever refrigerant pipes cross the wall/ceiling, a PVC pipe sleeve of adequate size shall be provided. The gap between PVC sleeve & refrigerant piping shall be filled up with fire rated insulating material & then make the surface to original level of wall.



TOWER AC UNITS

11) WATER COOLER

New water cooler shall be of following specifications

- i. The water cooler shall have hermetically sealed compressor and fan motor running on single phase $230 \pm 10\%$ Volts.
- ii. The water cooler shall be designed to operate at 35°C ambient temperature and inlet water temperature of 30°C . The outlet water temperature shall be 13.5°C and shall be controlled by means of thermostat.
- iii. Three core cable of at least 2 meters length with 3 pin plug shall be provided.
- iv. Chassis shall be of rigid construction made of 304 grade stainless steel non-corrosive rigid members with good finish. The outer cabinet of the water cooler shall be made of stainless steel non-corrosive sheets of 22 S.W.G. with decorative finish. The bottom portion of the cabinet shall be so constructed that there will be sufficient ventilation for hermetic unit and shall have removable panels for easy maintenance and repair works. The bottom portion of the cabinet facing to floor shall be covered by stainless steel-corrosive wire mesh of adequate thickness and mesh size to arrest rat nuisance and shall be above 100mm above from ground level. Also, the joints of outer casing shall be joined by stainless steel welding or stainless steel fasteners. The outer casing with members shall be manufactured from non-corrosive stainless steel.
- v. The water storage tank shall be of non-corrosive stainless steel of 22 S.W.G. and shall be leak proof and provided with float valve, overflow, drain connections for tank, preferably $\frac{3}{4}$ " size pipe with brass/ gun metal/ stainless steel non-corrosive gate valve. The overflow pipes outlet end shall be provided with perforated brass net/ nylon net with check nut to prevent entry of insects in the tank. The drain tray shall be made of sufficiently strong non-corrosive stainless steel sheet with a strainer. The separate drain water lines for drain tray and tank drain shall be provided for easy flow of drain water. The stainless steel non-corrosive lid shall be provided with locking arrangement and with rubber gasket to render the lid completely dust proof. The lid will have supporting arrangement on rear side to avoid damage to the hinges and panel of the water coolers. The internal parts & the connection inside the tank, float valves etc. shall be non-corrosive, non-toxic material so as not to contaminate the water and make it unsafe for human

TECHNICAL SPECIFICATIONS M&E

consumption.

- vi. The cleanable filter assembly (candle type) shall be fitted externally to the water cooler at inlet to the cooling unit. The offer shall be inclusive of filter assembly. The storage tank shall be insulated with PUF of suitable thickness.
- vii. The refrigerant used shall be colorless, non-irritating, non-toxic, non-inflammable, non-explosive and non-corrosive preferably freon-134a.
- viii. The refrigerant cycle shall give rated cooling effect and power consumption shall not exceed the rated value by more than 5%.
- ix. Each water cooler shall have following information marked in permanent or legible manner where it is easily accessible and visible after installation.
 - a) Name of water cooler including make, model and serial number of the unit, name and quantity of refrigerant.
 - b) Supply characteristics
 - c) Cooling capacity
 - d) Wiring diagram
 - e) Full load current



WATER COOLER

12) REFRIGERATOR

- i) Supply & installation of refrigerator of capacity 180-200 lit of reputed make-
 - Capacity 190 (\pm 10) LTR
 - Single door
 - Frost Free Operation
 - Stabilizer free operation
 - Rating :-minimum 2 & above Star
 - Optimal humidity
 - Moist free Zone.
 - Lock & key
- ii) Supply & installation of refrigerator of capacity 250-270 lit of reputed make-
 - Capacity 260 (\pm 10) LTR
 - Double door
 - Frost Free Operation

TECHNICAL SPECIFICATIONS M&E

- Stabilizer free operation
 - Rating:-minimum 2 & above Star
 - Optimal humidity
 - Moist free Zone. Lock & key
- iii) Supply & installation of refrigerator of capacity 290-310 lit of reputed make-
- Capacity 300 (\pm 10) LTR
 - Double door
 - Frost Free Operation
 - Stabilizer free operation
 - Rating:-minimum 2 & above Star
 - Optimal humidity
 - Moist free Zone.
 - Lock & key.



REFRIGERATOR

13) SITC OF DEEP FREEZER

The deep freezer outer cabinet & inner body shall be fabricated with 0.8 mm thick, powder coated mild steel sheet, rigidly fixed to the frame either by welding or by nut bolts. The deep freezer shall be insulated with 100 mm thickness high quality CFC free PUF insulation with high density polyurethane. The inner face of the door shall be made up of 1.2 mm thick 304 grade stainless steel sheet with moulded FRP lining. The door shall also be insulated with sufficient thickness high quality CFC free PUF insulation. The door shall be provided with good quality magnetic type gasket on inner side, so as to have the door sealed perfectly when locked. The door shall be provided with heavy duty latch with lock & key & shall have a good aesthetic look. It shall be provided with stainless steel hinges rigidly fixed to the main body of the deep freezer. The hinges shall be strong enough to withstand the frequent opening of the door. There should be no sharp corner inside and outside the chamber as per GMP requirement. All bends, corners and welded portions should be free from sharp edges. All fabrication work must be done on CNC based

TECHNICAL SPECIFICATIONS M&E

machines to avoid sharp corners. The body of the deep freezer shall be made in such a way that the condensing unit can be fixed either on the top or at the bottom of the deep freezer with ventilation arrangement for condenser and temperature indicating arrangement at visible level. The equipment shall be mounted on swivel castors with brakes. The deep freezer shall be CE certified.

i. Refrigeration system: The refrigeration system shall be single compressor type & suitable for the operation on 220 to 240 Volts, single phase, 50 Hz, A.C. Power Supply. The compressors of the unit shall be hermetically sealed and preferably good quality of any international brand, of reputed make having suitable capacity, high energy efficiency ratio and silent in operation and wider service network. The compressor mounting shall be good enough to remove it easily from the system if it needs repairs. The condenser shall be fin and tube type air-cooled having copper tubes & aluminum fins. The fins shall be equally spaced on the copper tubes to have high heat transfer. The entire condenser unit shall be mounted on the top or bottom of the deep freezer on suitable frame with anti vibrating pad for absorbing the jerks of the compressor, in such a way to have free circulation of air. The fan motor of the condenser shall be of single speed, fractional horse power; reputed make mounted on suitable frame and should be easily available in the market. The refrigeration system shall be connected with copper tubing of suitable thickness & size for proper flow of refrigerant. The system shall be charged adequately & tested before delivery. The system shall be fitted with over load protection relay. There shall be a proper base and provided with 4 Nos. of heavy duty castor wheel for the mobility of the deep freezer. The temperature inside the cabinet shall be maintained within limit. Deep Freezer shall have maintenance free temperature pack or system to retain temperature in sub zero condition for period 18 to 24 hrs with full load in close door condition, in case of power failure.

Refrigerant: - The refrigerant used in the refrigerator shall be non toxic, non hazardous, eco friendly CFC/HCFC free and shall be easily available in the market.



Deep Freezer

14) SITC OF MEDICAL REFRIGERATOR / LAB REFRIGERATOR :-

The refrigerator outer cabinet shall be powder coated mild steel sheet firmly fixed on the framework. The inner face of the door shall be made up of 304 grade stainless steel sheet. The door shall also be insulated with sufficient thickness high

TECHNICAL SPECIFICATIONS M&E

quality CFC free PUF insulation. The door shall be provided with good quality magnetic type gasket on inner side, so as to have the door sealed perfectly when locked. The door shall have a good aesthetic look. The hinges shall be strong enough to withstand the frequent opening of the door. All bends, corners and welded portion should be free from sharp edges. The refrigerator shall be CE certified. The refrigeration system shall be suitable for the operation on 220 to 240 Volts, single phase, 50 Hz, A.C. Power Supply. The compressors of the unit shall be hermetically sealed and preferably good quality of reputed make having suitable capacity, high energy efficiency ratio and silent in operation and wider service network. The compressor mounting shall be good enough to remove it easily from the system if it needs repairs. The entire condenser unit shall be mounted on the refrigerator on suitable frame with anti vibrating pad for absorbing the jerks of the compressor, in such a way to have free circulation of air. The fan motor of the condenser shall be of single speed, fractional horse power; reputed make mounted on suitable frame and should be easily available in the market. The refrigeration system shall be connected with copper tubing of suitable thickness & size for proper flow of refrigerant. The system shall be charged adequately & tested before delivery. The system shall be fitted with over load protection relay. The temperature inside the cabinet shall be maintained at 2^oC to 8^oC.

Refrigerant:- The refrigerant used in the refrigerator shall be non toxic, non hazardous, eco friendly CFC/HCFC free and shall be easily available in the market.

The control panel shall be inbuilt in laboratory refrigerator for its proper indication. The laboratory refrigerator shall be provided with reputed make good quality micro temperature controller system with LED display of temperature inside the cabinet with PT 100 RTD or NTC thermister sensor probe and audio-visual alarm system to aware the user if the temperature goes either below or above acceptable range. The minimum three meters of three core PVC copper cable along with three pin plugs shall be provided with the unit. Temperature controller must have audio-visual alarm system with battery backup system for indication of required temperature and alarming in case of temperature goes below or above acceptable range due to any mechanical or electrical error / fault. The storage system shall consist of five adjustable trays. The shelves shall be made up of S.S. 304 sheet of adequate thickness with perforations. The unit shall be tested in the Hospital after delivery and after loading full quantity of product to be stored. The contractor shall arrange this testing of the laboratory Refrigerators at his own cost.



MEDICAL REFRIGERATOR / LAB REFRIGERATOR

15) WALK IN COOLER REFRIGERATION UNIT:-

The refrigeration system shall comprise of neat, compact unit & cooling capacity of indoor unit & outdoor unit. The processing of the basic component of the refrigeration system shall be done on fully automatized finning machine which gives high dimensional accuracy and uniformity. The refrigeration system shall be self contained, side panel mounted. The compressor shall be hermetically sealed type unit with capillary control balanced system and its rated H.P. shall be specified. The evaporator section shall be compact, heavy duty and forced draft type to ensure fast cooling. The evaporator unit shall be designed, manufactured, calibrated and tested to ensure right temperature and humidity. The evaporator section shall be provided from the rear side panel and centrally installed. The thermostat shall be of reputed make and shall give accuracy of $\pm 1^{\circ}$ C & connected with audio/ visual alarm system & digital temperature indicator. The bellow of the thermostat shall be clamped inside the body at suitable place, so as to indicate the inside temperature of the inside cold room. The complete refrigeration system shall be suitable for operating on 230 Volts, single phase 50 c/s A.C. supply. A detachable receptacle tray shall be provided along with drainage piping for collection and disposal of the condensed water. The complete technical data of the refrigeration system as called for in the accompanying data sheet shall be furnished by filling the data sheet at the time of submitting the offer. The insulated panels sections shall be provided with tongue & groove design to enable minimize ingress of moisture between joints and enable extremely fast assembly with the help of CAM operated locks. An expanded polyethylene layer shall be provided on the interior and exterior of each panel to safeguard against transit damages.



WALK IN COOLER REFRIGERATION UNIT

16) **SITC OF FLOOR MOUNTED CHILLED WATER DOUBLE SKIN AIR HANDLING UNIT:-**

The double skin type air-handling units shall have outer casing pre-coated galvanized 0.8mm. Inner skin shall be 0.8 mm galvanized sheet. The insulation material i.e. CFC free puff shall be injected between two galvanized sheets. The framework shall be of extruded pre-coated aluminum section having internal channels for captive holding of neoprene gaskets. The drain pan shall be sufficiently extended to collect all condensate internally mounted with sloping sides for quick drain out and fabricated out of 1.2mm 304 stainless steel sheets, facing the inner condensate side and outer skin similar to the AHU outer skin. The drain pan shall have coil skid facility for easy installation/removal of coils. The fan shall be a direct driven backward / forward curved plug fans with VFD, outlet velocity not exceeding 10mps. The fan shall be of KRUGER/NIKOTRA make. The fan shall have pre-greased ball bearings sealed for life. The fan shall meet the external static, which may be required for supply and return air distribution. The fan and motor base shall be for minimum 50mm extruded aluminum sections. The unit base shall also be minimum 50mm.extruded aluminum sections or steel channel framework duly epoxy painted. The fan and motor shall be mounted on combination spring and rubber vibration isolators selected to match the power/weight ratio of each fan/motor combination for maximum isolation. The springs and vibration assembly shall be corrosion resistance. The fan and AHU housing shall be further isolated with a flexible non-flammable non-asbestos material connection. The cooling coils shall be constructed from adequate dia. round copper tubes combined with mild rippled fins and die formed directional guide channels. The fins shall be mechanically bounded to copper tubes. There shall be requisite rows of coils to provide necessary indoor conditions. Minimum 450 mm hinged access door shall be provided for easy access to the coils, fan etc. View port/opening with glass cover shall be provided on door to see /monitor fan & motor status. A safety "trip switch" shall be provided to automatically cutoff the electrical supply to the fan when access door is opened. The motor shall be energy efficient & TEFC (IP55) 3-phase squirrel cage connected to an electrical panel consisting of starters etc. All necessary material including

TECHNICAL SPECIFICATIONS M&E

foundation of AHUs for SITC of AHUs is included in scope of work. No extra payment will be made for this.



FLOOR MOUNTED CHILLED WATER DOUBLE SKIN AIR HANDLING UNIT

17) SITC OF CEILING SUSPENDED CHILLED WATER DOUBLE SKIN AIR HANDLING UNIT:-

The double skin type ceiling suspended chilled water air-handling units shall have outer skin 0.6 mm pre painted sheet with 275 GSM Zn coating. Inner skin shall be 0.6 mm galvanized sheet. The insulation material i.e. CFC free puff shall be injected between two galvanized sheets having 40 mm thickness. The framework shall be of extruded pre-coated aluminum section having internal channels for captive holding of neoprene gaskets. The construction of panels shall be screw less construction with zero leakage in the panel joints. The drain pan shall be sufficiently extended to collect all condensate internally mounted with sloping sides for quick drain out and fabricated out of 1.2mm 304 stainless steel sheets, facing the inner condensate side and outer skin similar to the AHU outer skin. The drain pan shall have coil skid facility for easy installation/removal of coils. There shall be requisite 6 or 8 rows of coils to provide necessary indoor conditions. Chilled water coil shall have 12.5 to 15 mm dia (O.D) tubes minimum 0.35 mm thick with sine wave aluminium fins firmly bonded to copper tubes assembled in zinc coated steel frame with SS Drain tray. View port/opening with glass cover shall be provided on door to see /monitor fan & motor status. The unit base shall also be minimum 50mm.extruded aluminum sections or steel channel framework duly epoxy painted. The fan and motor shall be mounted on combination spring and rubber vibration isolators selected to match the power/weight ratio of each fan/ motor combination for maximum isolation. The springs and vibration assembly shall be corrosion resistance. The fan shall be a direct driven backward / forward curved plug fans with VFD, with Squirrel cage IE2 induction motor. The fan shall be of KRUGER/NIKOTRA make. The fan shall meet the external static, which may be required for supply and return air distribution. Motor shall be suitable for operation of Variable Frequency Drive operation with 415±10% volts, 3 phase AC supply included with VFD. A safety "trip/ limit switch" shall be provided to automatically cutoff the electrical supply to the fan when access

TECHNICAL SPECIFICATIONS M&E

door is opened. Each unit shall be provided with a factory assembled filter section containing pre filters (EU-4) filters. Filter bank framework shall be fully sealed and constructed from GSS. Make of AHUs - MHP, NUTECH, ZECO, Voltas, Bluestar or reputed make. All necessary arrangement required for installation of ceiling suspended chilled water AHUs is included in scope of work. No extra payment will be made for this.



CEILING SUSPENDED CHILLED WATER DOUBLE SKIN AIR HANDLING UNIT

18) SITC OF DX DOUBLE SKIN AIR HANDLING UNIT :-

The double skin type Dx air-handling units shall have outer skin 0.6 mm pre painted sheet with 275 GSM Zn coating. Inner skin shall be 0.6 mm galvanized sheet. The insulation material i.e. CFC free puff shall be injected between two galvanized sheets having 40 mm thickness. The framework shall be of extruded pre-coated aluminum section having internal channels for captive holding of neoprene gaskets. The construction of panels shall be screw less construction with zero leakage in the panel joints. The drain pan shall be sufficiently extended to collect all condensate internally mounted with sloping sides for quick drain out and fabricated out of 1.2mm 304 stainless steel sheets, facing the inner condensate side and outer skin similar to the AHU outer skin. The drain pan shall have coil skid facility for easy installation/removal of coils. There shall be requisite 6 or 8 rows of coils to provide necessary indoor conditions. DX coil shall have 12.5 to 15 mm dia (O.D) tubes minimum 0.35 mm thick with sine wave aluminium fins firmly bonded to copper tubes assembled in zinc coated steel frame with SS Drain tray. View port/opening with glass cover shall be provided on door to see /monitor fan & motor status. The unit base shall also be minimum 50mm.extruded aluminum sections or steel channel framework duly epoxy painted. The fan and motor shall be mounted on combination spring and rubber vibration isolators selected to match the power/weight ratio of each fan/ motor combination for maximum isolation. The springs and vibration assembly shall be corrosion resistance. The fan shall be a direct driven backward / forward curved plug fans with VFD, with Squirrel cage IE2 induction motor. The fan shall be of KRUGER/NIKOTRA make. The fan shall meet the external static, which may be required for supply and return air distribution. Motor shall be suitable for operation of Variable Frequency Drive operation with 415±10% volts, 3 phase AC supply included with VFD. A safety "trip/ limit switch"

TECHNICAL SPECIFICATIONS M&E

shall be provided to automatically cutoff the electrical supply to the fan when access door is opened. Each unit shall be provided with a factory assembled filter section containing pre filters (EU-4) filters. Filter bank framework shall be fully sealed and constructed from GSS. All necessary material including foundation of AHUs for SITC of AHUs is included in scope of work. No extra payment will be made for this.



DX DOUBLE SKIN AIR HANDLING UNIT

19) DISMANTLING & REMOVING THE EXISTING FALSE CEILING DURATUFF/ EQUIVALANT SHEET ALONGWITH DIFFUSER GRILL AND REFIX THE SAME AFTER CLEANING

The existing false ceiling sheets along with supply/return air diffusers/grills shall be removed carefully without damaging grid work/sheets as directed by Site Engineer. All the area above the removed false ceiling shall be cleaned. The existing removed false ceiling sheets & diffusers/grills, which are in good condition & to be reused, shall be cleaned properly and kept in the hospital premises as directed by the hospital authority. The diffusers/grills shall be painted on both side with one coat of primer and two coats of synthetic enamel paint of white shade. The successful contractor shall refix these cleaned sheets & painted diffusers/grills neatly on the existing framework of aluminium tees suspended with M.S. Rods after carrying insulation work of ducting wherever necessary. Before fixing the cleaned sheets the existing aluminium grid work shall be repaired, realigned. The damaged aluminium members of grid work shall be replaced & if required additional supports of 6 mm dia. ms rods suspended from ceiling to grid work shall be provided as per the direction of site engineer. All the suspended bars shall be painted with two coats of anticorrosive red oxide paint. The complete boxing shall be made airtight by using felt or pop to minimize the losses of conditioned air.

20) REPLACEMENT OF EXISTING DAMAGED FALSE CEILING SHEET BY NEW FALSE CEILING DURATUFF/ EQUIVALENT SHEET.

The existing false ceiling sheets along with supply/return air diffusers/grills shall be removed carefully without damaging grid work as directed by Site Engineer. All the area above the removed false ceiling shall be cleaned. The existing removed old false

TECHNICAL SPECIFICATIONS M&E

ceiling sheets, supply/return air diffusers/grills shall be kept in the hospital premises as directed by the hospital authority. The successful contractor shall replace the damaged sheets of the false ceiling by new duratuff sheets of size 600 mm X 600 mm or as per requirement, made up of requiredthick, on the existing framework of tees suspended with M.S. Rods after carrying out ducting & insulation work wherever necessary. The opening for lighting /fan/air diffuser & grill arrangement shall be provided in the false ceiling as directed & if required. Before fixing the sheets the existing aluminium grid work shall be repaired, realigned. The damaged aluminium members of grid work shall be replaced & if required additional supports of 6 mm dia. ms rods suspended from ceiling to grid work shall be provided as per the direction of site engineer. All the suspended bars shall be painted with two coats of anticorrosive red oxide paint. The complete boxing shall be made airtight by using felt or pop to minimize the losses of conditioned air.

21) SUPPLY AND INSTALLATION OF FALSE CEILING OF MEDIUM DENSITY FIBER BOARD ALONG WITH GRID WORK.

The successful contractor shall replace the sheets of the false ceiling by new sheets of size 600 mm X 600 mm, made up of medium density fiberboards of 12 mm thick, both sides laminated on the existing framework of aluminium tees suspended with M.S. Rods after carrying out ducting & insulation work wherever necessary. The opening for lighting /fan/air diffuser & grill arrangement shall be provided in the false ceiling as directed & if required. if required additional supports of 6 mm dia. ms rods suspended from ceiling to grid work shall be provided as per the direction of site engineer. All the suspended bars shall be painted with two coats of anticorrosive red oxide paint. The complete boxing shall be made airtight by using felt or pop to minimize the losses of conditioned air.

22) REPLACEMENT OF OF EXISTING DAMAGED FALSE CEILING SHEET BY NEW FALSE CEILING OF MEDIUM DENSITY FIBER BOARD

The existing false ceiling sheets along with supply/return air diffusers/grills shall be removed carefully without damaging grid work as directed by Site Engineer. All the area above the removed false ceiling shall be cleaned. The existing removed old false ceiling sheets, supply/return air diffusers/grills shall be kept in the hospital premises as directed by the hospital authority. The successful contractor shall replace the damaged sheets of the false ceiling by new sheets of size 600 mm X 600 mm, made up of medium density fiberboards of 12 mm thick, both sides laminated on the existing framework of aluminium tees suspended with M.S. Rods after carrying out ducting & insulation work wherever necessary. The opening for lighting /fan/air diffuser & grill arrangement shall be provided in the false ceiling as directed & if required. Before fixing the sheets the existing aluminium grid work shall be repaired, realigned. The damaged aluminium members of grid work shall be replaced & if required additional supports of 6 mm dia. ms rods suspended from ceiling to grid work shall be provided as per the direction of site engineer. All the suspended bars shall be painted with two

TECHNICAL SPECIFICATIONS M&E

coats of anticorrosive red oxide paint. The complete boxing shall be made airtight by using felt or pop to minimize the losses of conditioned air.

23) SUPPLY AND INSTALLATION OF ALUMINUM FALSE CEILING SHEETS ALONG WITH GRID WORK

The successful contractor shall provide new aluminium ceiling sheets after completion of duct insulation work. The aluminium sheets shall be of size 600 mm X 600 mm and of thickness 16 SWG. The ceiling grid work shall be provided with aluminium tees of size 38 mm X 25 mm X 1.6 mm thick duly suspended from the ceiling at suitable distance by M.S. rods of 6 mm dia. All the suspended bars shall be painted with two coats of anticorrosive red oxide paint. The complete boxing shall be made air tight by using felt or pop to minimize the losses of conditioned air.

24) REPLACEMENT OF EXISTING DAMAGED FALSE CEILING BY NEW ALUMINUM FALSE CEILING SHEETS ALONG WITH GRID WORK

The exiting damaged false ceiling along with its grid frame work shall be removed carefully. The successful contractor shall replace the damaged false ceiling by providing new false ceiling after completion of duct insulation work. The false ceiling sheets shall be of size 600 mm X 600 mm, made up of medium density fiberboards of 12 mm thick, both sides laminated. The false ceiling grid work shall be provided with aluminium tees of size 38 mm X 25 mm X 1.6 mm thick duly suspended from the ceiling at suitable distance by M.S. rods of 6 mm dia. All the suspended bars shall be painted with two coats of anticorrosive red oxide paint. The complete boxing shall be made air tight by using felt or pop to minimize the losses of conditioned air.

25) SUPPLY AND INSTALLATION OF FALSE CEILING OF BAKELITE SHEETS ALONG WITH GRID WORK.

The new return air boxing along with false ceiling shall be fabricated from 4 mm thick Bakelite sheets duly insulated with heatlon sheets from inner side to prevent heat loss & condensation. The framework shall be fabricated from teak wood battens of size 2" x 1.5" with grid work of 2' x 4' or 2' x 2'. The framework shall be suspended from the ceiling at suitable distance by M.S. rods of 6 mm dia. The rods shall be suitably suspended from the ceiling by clips of adequate strength anchored properly in the ceiling. All the M.S. rods shall be painted with two coats of anticorrosive red oxide paint. The opening for lighting /fan/air diffuser & grill arrangement shall be provided in the false ceiling as directed & if required. The return air boxing shall be made airtight by using felt, pop, cement etc. The opening made in the ceiling for fixing support shall be filled with cement.

26) REPLACEMENT OF EXISTING DAMAGED FALSE CEILING BY DISMANTLING & REMOVING THE EXISTING DAMAGED FALSE CEILING ALONG WITH GRID AND PROVIDING THE NEW FALSE CEILING OF BAKELITE SHEETS.

The exiting damaged false ceiling along with its grid frame work shall be removed carefully. All the area above the removed false ceiling shall be cleaned. The

TECHNICAL SPECIFICATIONS M&E

successful contractor shall replace the damaged false ceiling by providing the new return air boxing along with false ceiling shall be fabricated from 4 mm thick Bakelite sheets duly insulated with heatlon sheets from inner side to prevent heat loss & condensation. The framework shall be fabricated from teak wood battens of size 2" x 1.5" with grid work of 2' x 4' or 2' x 2'. The framework shall be suspended from the ceiling at suitable distance by M.S. rods of 6 mm dia. The rods shall be suitably suspended from the ceiling by clips of adequate strength anchored properly in the ceiling. All the M.S. rods shall be painted with two coats of anticorrosive red oxide paint. The opening for lighting /fan/air diffuser & grill arrangement shall be provided in the false ceiling as directed & if required. The return air boxing shall be made airtight by using felt, pop, cement etc. The opening made in the ceiling for fixing support shall be filled with cement.

27) REPLACEMENT OF DAMAGED ALUMINIUM CEILING BY DISMANTLING & REMOVING THE EXISTING CEILING ALONG WITH CARRIER AND PROVIDING THE NEW ALUMINIUM LINEAR METAL CEILING

The existing damaged aluminium false ceiling shall be removed carefully along with carrier. The new false ceiling shall be of 0.5 mm thick aluminium sheets panels of 84 mm width, 15mm depth & length upto 5 mtr. Alongwith 25 mm recess flange. The perforation of 2 mm. dia. & 5 mm pitch of diagonal pattern shall be made to these panels. The carrier shall be fabricated from 0.5 mm thk. galvanized steel sheet (stove enameled black) & of size 28mm width x 43mm. deep to hold panel in module of 100 mm. The carrier framework shall be suspended from the ceiling at suitable distance by GI rods of 4 mm dia. The rods shall be suitably suspended from the ceiling by 0.5 mm thk. Spring steel clips of adequate strength anchored properly in the ceiling. The necessary arrangement shall be made for height adjustment with the help of panel coupler, carrier coupler & wall angles. All the panels shall be powder coated with 50 micron thickness on exposed surface. The opening for lighting/ fan/ air diffuser & grill arrangement shall be provided in the false ceiling as directed & as per existing one. The ceiling shall be made airtight by using felt, pop, cement etc. The opening made in the ceiling for fixing support shall be filled with cement.

28) REPLACEMENT SUPPLY & INSTALLATION OF GYPSUM FALSE CEILING

False ceiling should be carried out with lightweight boards made of basic materials like aerated gypsum treated with special additives, and both sides are covered with a special off white/white colour paper. The size, thickness and texture of the board or tile available are as per the manufacturer details. Make – India gypsum, Gyproc, Oman or equivalent.

29) REMOVING THE EXISTING WORN OUT GLASS WOOL BAGS ON THE FALSE CEILING BY DISMANTLING & REMOVING THE EXISTING FALSE CEILING & INSTALLING NEW GLASS WOOL BAGS ON THE FALSE CEILING

The existing damaged glass wool bags on the above aluminium false ceiling shall be removed. The glass wool 50 mm. thick (150 densities) shall be filled up in the

TECHNICAL SPECIFICATIONS M&E

polythene bags. These bags shall be neatly spread over the new aluminium false ceiling.

30) SUPPLY AND INSTALLATION OF VOLUME CONTROL DAMPERS/ BYPASS DAMPERS

The new volume control dampers /by pass dampers of suitable size shall be fabricated from 16 SWG galvanized steel sheet and shall provided on the place of removed dampers. These dampers shall be properly marked with colour code for opening & closing.



VOLUME CONTROL DAMPERS/ BYPASS DAMPERS

31) PROVIDING FRESH AIR DAMPER WITH CROWL PIECE, BIRD SCREEN & REMOVABLE TYPE PREFILTERS

A suitable fresh air damper of requisite size shall be fabricated & installed in the AHU rooms by making opening in the wall of AHU rooms. The damper shall be provided with a galvanized sheet steel cover with cowl and bird screen. The damper shall be opposed blade louver type fabricated from 16 SWG galvanized sheet steel.

32) PROVIDING ALUMINIUM SUPPLY AIR DIFFUSERS & RETURN AIR GRILLS WITH VOLUME CONTROL DAMPERS

The supply air diffusers & return air grills shall be of standard design rectangular / circular in shape and of appropriate size, adjustable pattern and the bars shall hold the deflection, settings under all conditions of velocity and pressure to control the direction, quantity of flow of cool air. The entire grill shall be of aluminium and powder coated with epoxy paint of approved shade. The wooden frame duly painted to match the color of the surroundings shall be provided if necessary.

33) REPLACEMENT OF EXISTING DAMAGED RELIEF DAMPERS BY PROVIDING NEW GRAVITY OPERATE RELIEF DAMPERS WITH SCREEN CONSISTING OF GI FRAME, ALUMINIUM LOUVERS & GI WIRE MESH

The existing damaged/ corroded relief dampers which are not operatable shall be removed carefully without damaging the existing civil structure. The relief dampers for exhausting the air from the conditioned space to the atmosphere shall be gravity operated type & made out of G.I. frame, aluminium louvers. G.I. wire mesh of suitable

TECHNICAL SPECIFICATIONS M&E

gauge with mesh of 6mm. x 6mm size shall be provided on outer side to arrest entry of rats, birds etc.

34) REPLACEMENT OF THE EXISTING DAMAGED /LOOSED GLASS WOOL INSULATION OF DUCTING WITH NEW GLASS WOOL INSULATION

The damaged & loosed portion of existing glass wool insulation of ducts shall be removed without damaging ducting as directed by site engineer and the external surface shall be cleaned thoroughly. The surface of supply air duct shall be insulated with glass wool of 50 mm. thick (150 density) with aluminium foil by applying necessary coats of tar on the duct surface. The sufficient overlapping on the joints shall be finally sealed with 50 mm. wide PVC adhesive tape. The supports of MS rods and angles duly painted shall be provided to ducting if required as per the direction of site engineer.

35) REPLACEMENT OF THE EXISTING DAMAGED / LOOSED THERMAL INSULATION OF DUCTING WITH NEW 50MM THICK TF QUALITY THERMOCOL WRAPPED WITH CHICKEN WIRE MESH, COVERED WITH 12MM THICK CEMENT PLASTER, FINISHED WITH NEEROO

The damaged & loosed portion of existing thermal insulation of ducts shall be removed without damaging ducting as directed by site engineer and the external surface shall be cleaned thoroughly. The surface of supply air duct shall be insulated with 50 mm. thick T.F. quality thermocole by applying necessary coats of tar on the duct surface. The thermocole shall be covered with wire mesh of suitable thickness and size and shall be finished with 12mm thick layer of water proof cement plaster with neeroo finish. The supports of MS rods and angles duly painted shall be provided to ducting if required as per the direction of site engineer.

36) REPLACEMENT OF THE EXISTING DAMAGED/ LOOSED INSULATION OF DUCTING & TO CARRY OUT THE NEW INSULATION WITH 50MM THICK TF QUALITY THERMOCOL WRAPPED WITH 0.9MM THICK ALUMINIUM FOIL

The damaged & loosed portion of existing thermal insulation of S.A. & R.A. ducts shall be removed without damaging ducting as directed by site engineer and the external surface shall be cleaned thoroughly. After cleaning the surfaces, of S.A. & R.A. duct, the same shall be insulated with 50 mm thick T.F. quality thermocole. The thermocole shall be fixed by applying necessary initial coat of bitumen compound to the external surfaces. The thermocole shall be finally wrapped with 0.09 mm thick Aluminium foil by applying tar/ bitumen etc. sufficient overlapping on the joints shall be finally sealed with 50 mm wide PVC adhesive tape. The additional supports to ducting of MS rods and angle duly painted shall be provided to ducting if required as per the direction of site engineer.

37) PROVIDING THERMAL INSULATION TO DUCTING WITH NITRILE RUBBER

The surface of supply air & return duct shall be insulated with EPDM based closed cell elastomeric thermal insulation flexible sheet & shall confirm to relevant standard.

TECHNICAL SPECIFICATIONS M&E

Application Process - Clean the surface of duct to be insulated free from dust, grease and other materials. Choose the recommended thickness of EPDM (Ethylene Propylene Diene Monomer) sheet and cut it to match the size of the duct using sharp knife. Ensure that the cut is straight & do not stretch the sheets. Apply a thin coat of Neoprene based contact adhesive on EPDM sheet as well as the duct surface using a brush and leave it 5 to 30 minutes for drying, Remove any surplus adhesive with a suitable hydrocarbon solvent. Once the adhesive is dry but tacky to touch bring the EPDM sheet and the duct surface in contact and apply slight firm pressure to stick them well ensure that there are no air pockets in between and that all the joints match properly. Self Adhesive elastomeric gasket tape shall be used in duct flanges to prevent the Air leakages.



NITRILE RUBBER

38) SUPPLY AND FIXING ACCOUSTIC PARTITION IN PLANT ROOM / AHU ROOM

(iii) Perforated hardboard sheet type-

Acoustic partition work shall be carried out for plant rooms as per specifications & site engineer's instructions. The framework of partition shall be fabricated by using teak wood batten of size 2" x 2". The grid work shall be of size 2' x 2'. The outer surface of partitions shall be covered with plywood of 12 mm thickness. The quality of glass wool (150 density, 50mm. thick) shall be fixed in the framework. This will be covered internally by perforated hardboard sheets 4mm thk& same shall be screwed properly. The bidding work shall be carried out by supplying & fixing of teak wood patti of size 25 mm X 3 mm thick at joints duly fixed on frame work with screws. All the wooden work of the partition shall be thoroughly treated with anti termite treatment before carrying out acoustic treatment. To paint the outer surface of plywood with two coats of enamel paint of approved shade.

(iv) Aluminium sheet type-

Acoustic partition work shall be carried out at sidewall of plant room as per specifications & site engineer's instructions. The framework of partition shall be fabricated by using aluminium square hollow pipe of 16 gauge & sizes 2" x 2 ". The grid work shall be of size 3' x 2'. The outer surface of partitions facing corridor shall be covered with plane aluminium sheet. The quality of glass wool (150 density, 50mm thick) shall be fixed in the Aluminium framework. This will be covered by Aluminium

TECHNICAL SPECIFICATIONS M&E

perforated sheets screwed properly. The perforated sheets shall be firmly fixed on Aluminium pipe framework from inside plant room. The bidding work shall be carried out by supplying & fixing of 1" width Aluminium strips (16 SWG) at joints duly fixed on frame work with S.S. metal screws. To paint the plane GI sheet of partition outer surface with two coats of enamel paint of approved shade.

39) REPLACEMENT OF EXISTING DAMAGED ACOUSTIC PARTITION IN THE PLANT ROOM

The existing damaged acoustic partition in plant room/ AHU room and provide new insulation as follows-

(i) Perforated hardboard sheet type-

Acoustic partition work shall be carried out for plant rooms as per specifications & site engineer's instructions. The framework of partition shall be fabricated by using teak wood batten of size 2" x 2". The grid work shall be of size 2' x 2'. The outer surface of partitions shall be covered with plywood of 12 mm thickness. The quality of glass wool (150 density, 50mm. thick) shall be fixed in the framework. This will be covered internally by perforated hardboard sheets 4mm thk & same shall be screwed properly. The bidding work shall be carried out by supplying & fixing of teak wood patti of size 25 mm X 3 mm thick at joints duly fixed on frame work with screws. All the wooden work of the partition shall be thoroughly treated with anti termite treatment before carrying out acoustic treatment. To paint the outer surface of plywood with two coats of enamel paint of approved shade.

(ii) Aluminium sheet type-

Acoustic partition work shall be carried out at sidewall of plant room as per specifications & site engineer's instructions. The framework of partition shall be fabricated by using aluminium square hollow pipe of 16 gauge & sizes 2" x 2". The grid work shall be of size 3' x 2'. The outer surface of partitions facing corridor shall be covered with plane aluminium sheet. The quality of glass wool (150 density, 50mm thick) shall be fixed in the Aluminium framework. This will be covered by Aluminium perforated sheets screwed properly. The perforated sheets shall be firmly fixed on Aluminium pipe framework from inside plant room. The bidding work shall be carried out by supplying & fixing of 1" width Aluminium strips (16 SWG) at joints duly fixed on frame work with S.S. metal screws. To paint the plane GI sheet of partition outer surface with two coats of enamel paint of approved shade.

40) SUPPLY AND FIXING ACOUSTIC INSULATION IN PLANT ROOM/ AHU ROOM

a) Perforated hardboard sheet type-

The acoustic insulation in the plant room shall be made from fiber glass, hard board sheets & wooden frame work shall be removed without damaging the civil structure. The contractor shall disconnect the existing cable connections, switch boards etc. provided in the plant room & refix neatly after carrying out the work of acoustic treatment. Acoustic paneling will be carried out by supply and making frame with teak wood batten of size of 1 1/2" x 2". The grid size of frame work shall be @ 2' x 2'. The frame work shall be fixed on walls properly. The glass wool 50mm. thick (150 density)

TECHNICAL SPECIFICATIONS M&E

shall be fixed in grid work & then finally it will be covered with perforated hardboard sheets. The joints shall be bided with teak wood patti of size 25 mm X 3 mm thick. All the wooden work in the plant room shall be thoroughly treated with antitermite treatment before carrying out acoustic treatment

b) Aluminium sheet type-

The existing damaged acoustic insulation in the plant room made from fiber glass, aluminium sheets & GI frame work shall be removed without damaging the civil structure. The contractor shall disconnect the existing cable connections, switch boards etc. provided in the plant room & refix neatly after carrying out the work of acoustic treatment. Acoustic paneling will be carried out by supply and fabrication of G.I. channel frame with channel size of 2" x 2", gauge 16 SWG. The grid size of frame work shall be @ 3' x 2'. The frame work shall be fixed on walls properly. The glass wool 50mm. thick (150 density) shall be fixed in grid work & then finally it will be covered with perforated Aluminium sheet (26 SWG). The bidding work shall be carried out by supplying & fixing of 1" width Aluminium strips (16 SWG) at joints duly fixed on frame work with S.S. metal screws

41) REPLACEMENT OF EXISTING DAMAGED ACOUSTIC INSULATION IN THE PLANT ROOM/ AHU ROOM

The damaged & loosed portion of existing damaged acoustic insulation in plant room / AHU room and provide new insulation as follows-

a) Perforated hardboard sheet type-

The existing damaged Acoustic insulations in the plant rooms shall be removed without damaging the existing wooden frame work. Acoustic treatment to the plant room shall be provided by using 50 mm thick crown 150 quality fiber glass lined in the existing wooden frame work and shall be covered with hard board sheets as per existing texture. The additional teak wood supports to the existing wooden frame shall be provided wherever necessary. The joints shall be bided with teak wood patti of size 25 mm X 3 mm thick. All the wooden work in the plant room shall be thoroughly treated antitermite treatment before carrying out acoustic treatment. The contractor shall disconnect the existing cable connections, switchboards etc. provided on the damaged portion of acoustic insulation in plant room & refix the same neatly after carrying out the repairs work of acoustic insulation.

b) Aluminium sheet type-

The existing damaged Acoustic insulations in the plant rooms shall be removed without damaging the existing G.I. channel frame work channel size of 2" x 2", gauge 16 SWG. Acoustic treatment to the plant room shall be provided by using 50 mm thick crown 150 quality fiber glass lined in the existing wooden frame work and shall be covered with perforated Aluminium sheet (26 SWG). The bidding work shall be carried out by supplying & fixing of 1" width Aluminium strips (16 SWG) at joints duly fixed on frame work with S.S. metal screws. The additional G.I. channel frame work supports to the existing frame shall be provided wherever necessary. The contractor shall disconnect the existing cable connections, switchboards etc. provided on the damaged

TECHNICAL SPECIFICATIONS M&E

portion of acoustic insulation in plant room & refix the same neatly after carrying out the repairs work of acoustic insulation.

42) SUPPLY AND INSTALLATION OF UNDER DECK ROOF INSULATION WITH TEAK WOOD FRAME AND 50MM THICK TF QUALITY THERMOCOL COVERED WITH FOAM SHEET

New under deck insulation shall be carried out by providing & fixing the teak wood frame work of size 600mm x 1200mm at the ceiling by using suitable size screws. The teak wood frames shall be fabricated by using teak wood battens of size 50mm x 38mm. Thermocole sheets of 50 mm thickness and suitable size shall be fixed in above teak wood frame work by using hot bitumen on ceiling. The entire thermocole sheets shall be covered by using 2mm thick PVC foam sheets. These PVC sheets shall be fixed to the teak wood frames by using adequate and suitable size of screws. Bidding with the same material as that of PVC sheets shall be provided at the sheet's joints and edges. The complete under deck insulation shall be made airtight by using felt or pop to avoid condensation of humid air in the room.

43) REPLACEMENT OF UNDER DECK ROOF INSULATION WITH 50MM THICK TF QUALITY & GI WASHER ()

The existing damaged under deck insulation in the room shall be removed carefully without damaging the civil structure. The under deck insulation shall be provided to the ceiling by using 50 mm thick TF quality thermocole sheets. The thermocole sheets of suitable size & 50 mm thick shall be fixed to the ceiling by using hot bitumen. The joints of the sheets shall be covered by suitable size of screws & GI washers of size 3" x 3". There should not be any gap between two thermocole.

44) TO PROVIDE SCREEN ARRANGEMENT TO RETURN AIR OPENING IN THE AHU ROOM/PLANT ROOM

There are return air duct openings in the plant rooms/ AHU rooms for return air applications. Due to this opening there is rat nuisance. To avoid this screen arrangement shall be provided. This shall be fabricated from the aluminium wire of 24 gauge and fixed with the wooden frame made up of teak wood pattern of size 2" X 1 ½" on the return air opening properly.

45) GSS DUCTING -

The duct shall be fabricated from 20/22/24 SWG galvanized iron sheet (G.I.S.) as per required size of the duct. The duct shall be fabricated & installed in best workman ship manner. All the joints shall be made leak proof by providing felt strips. Stiffeners of M.S. flats or angles duly painted with one coat of anticorrosive primer and two coats of synthetic enamel of approved quality shall be provided for longer length & longer cross section of duct. It shall be the responsibility of the contractor to ensure the rigidity of the ducting. The work include of Supplying, fabrication, installation, testing and commission of G.I. Sheet metal ducting with Zinc coated of minimum 160GSM. Complete with all standard Accessories, GI hardware, self Adhesive electrometric

TECHNICAL SPECIFICATIONS M&E

foam gasket, support etc as per SMACNA specifications. (Sheet Metal and Air conditioning Contractors National Association)



GSS DUCTING

46) ALUMINIUM DUCTING-

The duct shall be fabricated from 20/22/24 SWG Aluminium sheet as per required size of the duct. The duct shall be fabricated & installed in best workman ship manner. All the joints shall be made leak proof by providing felt strips. Stiffeners of flats or angles duly painted with one coat of anticorrosive primer and two coats of synthetic enamel of approved quality shall be provided for longer length & longer cross section of duct. It shall be the responsibility of the contractor to ensure the rigidity of the ducting. The work includes of Supplying, fabrication, installation, testing and commission of Aluminium Sheet metal ducting with a) sealant, b) Gaskets, c) Structural support system, d) nuts & bolts, e) angles, f) closed cell neoprene gaskets etc.



ALUMINIUM DUCTING

47) PROVIDING ACOUSTIC LINING TO THE INITIAL PORTION OF SUPPLY AIR DUCT FROM INSIDE OF THE DUCTING USING FIBRE GLASS CROWN 300x25MM THICK RIGID BOARD OR EQUIVALENT INSULATION MATERIAL COVERED WITH 24 GAUGE PERFORATED ALUMINIUM FOIL.

Initial portion of supply air duct up to plenum shall be acoustically treated from inside using fibreglass crown 300 x 25 mm thick rigid boards or equivalent insulating material.

TECHNICAL SPECIFICATIONS M&E

The insulation shall be covered from all side using 24 gauge perforated Aluminum foil. The insulation shall be fixed to the duct using G.I. nut bolts and washers at a distance of not more than 8” by drilling the holes in the ducting. The bolts shall be fully tightened so as to avoid sagging of insulating material.

48) REPLACEMENT OF DAMAGED THERMAL INSULATION WITH NEW NITRILE RUBBER WITH GLASS CLOTH TO CHILLED WATER PIPE LINE

The existing damaged thermal insulation of chilled water pipe line shall be removed. The pipe surface shall be cleaned by removing scales. The Chiller Water pipe line shall be reinsulated by new Nitrile rubber with Glass cloth to chilled water pipe line.

49) SUPPLY, INSTALLATION OF M.S. ‘C’ CLASS CHILLED WATER PIPE LINE/ DRAIN LINE ALONG WITH ACCESSORIES AND THERMAL INSULATION OF THERMOCOL-

The chilled water pipeline shall be MS ‘C’ class pipes of suitable sizes as per requirement. The pipeline work shall be complete with necessary hydraulic fittings such as bends, elbows, tees, reducers, flanges, coupling unions, etc. The M.S. support shall be given wherever necessary to support the pipeline. This shall be provided from central A.C plant to air handling units duly insulated with 50 mm thick T.F. thermocole, fixed to the pipeline by tar bitumen and finished with cement plaster reinforced with chicken wire mesh. The outer surface shall be neeroo finished and painted with two coats of synthetic enamel paint of approved make &shade

50) SUPPLY, INSTALLATION OF M.S. ‘C’ CLASS CHILLED WATER PIPE LINE/ DRAIN LINE ALONG WITH ACCESSORIES AND THERMAL INSULATION OF NITRILE RUBBER WITH GLASS CLOTH-

The chilled water pipeline shall be MS ‘C’ class pipes of suitable sizes as per requirement. The pipeline work shall be complete with necessary hydraulic fittings such as bends, elbows, tees, reducers, flanges, coupling unions, etc. The M.S. support shall be given wherever necessary to support the pipeline. This shall be provided from central A.C plant to air handling units duly insulated with nitrile rubber insulation.

51) SUPPLY & INSTALLATION OF G.I. CLASS ‘B’ CONDENSER PIPELINE, WITH THERMAL INSULATION OF THERMOCOL-

The chilled water pipeline shall be G.I. ‘B’ class pipes of suitable sizes as per requirement. The pipeline work shall be complete with necessary hydraulic fittings such as bends, elbows, tees, reducers, flanges, coupling unions, etc. duly insulated with 50 mm thick T.F. thermocole, fixed to the pipeline by tar bitumen and finished with cement plaster reinforced with chicken wire mesh. The M.S. support shall be given wherever necessary to support the pipeline. The outer surface shall be neeroo finished and painted with two coats of synthetic enamel paint of approved make &shade.

52) SUPPLY AND INSTALLATION OF VALVES AND ACCESSORIES-

a) Butterfly valves

TECHNICAL SPECIFICATIONS M&E

The butterfly valve shall be supplied along with Flow control lever. The valves shall be compact in size and shall conform to IS-13095/BS 5155/API 609. The valves shall be light in weight and easy to install. The body shall be of high duty cast iron conforming to BS: 1452 Grade 200. The disk shall be of ductile iron with nylon coated, whereas the shaft shall be treated permanently for lubrication. The shaft seals shall be of Nitrile 'O' rings and rubber seals. Valves shall be suitable for a working pressure of 10 Kg/sq.cm test pressure maximum 15kg/cm². Care should be taken during installation to see that the disk is not damaged during installation due to the flanges being incorrectly spaced. The valves shall be insulated with 50 mm. thick T.F. quality thermocole stick with tar and covered with chicken wire mesh and plastered with cement & smooth with neroo & painted with two coats of synthetic enamel paint of approved make and shade.

b) **Ball Valve-**

Ball valve shall be full borne in one piece/ two piece / three piece construction. The valve shall confirm to IS 9890. The body and end connectors shall be of Brass-Gunmetal. The ball shall be of SS/Brass-Gunmetal as per BS2872. The seal should be PTFE and stem should be in SS or Brass-Gunmetal. The O ring shall be suitable for 100deg C temperature. The operating lever should be of carbon steel sheet. Valve shall be screwed female parallel threads as per BS 21. Valve shall be suitable for 10Kg/cm² operating pressure.

c) **Non- Return Valve-**

The Non return valve shall normally be used in all water services. Air release and clean out plugs shall be provided and valves shall be suitable for not less than 10 kg per sq cm gauge working pressure. Tail pieces shall be used where required.

Size	Construction	Ends
15 to 35 mm	Gun Metal	Flanged
35 to 65 mm	Gun Metal	Flanged
75 mm and over	Body Cast iron. Spindle and valve seat of Bronze or Gun Metal or Black Rubber	Flanged

d) **Balancing Valve:**

Manual operated balancing valves shall have built-in pressure-drop measuring facility to compute flow rate across the valve. The test cocks shall be long enough to protrude out of pipe insulation. The valve shall confirm to BS 7350. Balancing valves up to 50mm shall have gunmetal body as per IS 318 and valve above 50mm shall have cast iron body as per IS 210. Gr.220/ BS-1452 / ASTMA48/GG20. The Bonnet shall be of Cast iron and SS disc. It should have PTFE/EPDM seal with graphite asbestos gland packing as per IS 4678 with non rising spindle of brass/SS 410sealedwith Teflon. The valve should be with flanged end above 50mm drilled to IS 6392

e) **Pot / 'Y' Strainer:**

Strainer shall be preferably Pot / 'Y' type as specified in the tender schedule with CI /Fabricated bodies. Strainer shall have a removable SS / Brass screen with 14 Mesh for

TECHNICAL SPECIFICATIONS M&E

Pot Strainer & 3mm perforation for 'Y' Strainer. Strainers shall be flanged. They shall be designed so as to enable blowing out accumulated dirt and facilitate removal and replacement of all screens without disconnection from the main pipe. Strainers shall be provided with isolating valves so that they may be cleaned without drawing the entire system. Dust / Dirt collection basket shall be fabricated from stainless steel mesh. The Pot strainer body shall be fabricated as per relevant IS. The Pot strainer shall comprise of flushing inlet valve.

f) Auto air Vent

Air release valve and clean out plugs to be provided wherever required. Air Purge/ vent valves shall be provided at all high points in the piping system for discharging the air in the piping system. The body shall be of gunmetal/brass with strainer and the float constructed in Polypropylene and leverage shall be stainless steel.

g) Float Valve

The float valve shall be heavy duty of brass / gun metal and of approved make such as Crescent / Sant / Leader etc.

h) Brass/ gun metal gate valve

The gate valve shall be heavy duty of brass / gun metal and of approved make such as Crescent / Sant / Leader etc.

i) Supply and installation of M.S. base frame

New M.S. base frames fabricated from ISMC100 of 450 mm length and shall be grouted in proper cement concrete mix with foundation bolts. The Fixing Bolt in the foundation block shall be Stainless steel. Spring type Isolation shall be used and rubber pads are not permitted. R.C.C. floating foundation for chilled water and condenser water pumps with angle iron frame at the edge to protect from damages

j) Pressure gauge

Pressure gauges shall be provided on chiller water pipe line inlet and outlet with 3/8" dia meter gate valve. The pressure gauges shall be of diaphragm type with necessary fittings having pressure range 0 to 100 psi.

k) Digital Temperature indicator

New Temperature Indicators in the Plant room shall give correct temperature readings. The new supplied sensors shall be calibrated. The temperature sensor shall be RTDPT-100 type. The range of the same shall be -10° c to + 50° c.

l) Stem Type Thermometer

The stem type industrial thermometer shall be installed on the condenser water pipeline. The thermometer shall be provided with thermo-well in the condenser water pipe line to indicate temperature of incoming and outgoing condenser water of the central A.C plant. Make:- Feibig / H Guru.

m) Two / Three Way Mixing/ Diverting Zone Valves

Single seated two ways globe/control valves shall be used where low seat leakage is desired & operating pressure is relatively low. These are unbalanced valves. Double-seated globe valves shall be used for controlling the flow of high-pressure fluid. The flow

TECHNICAL SPECIFICATIONS M&E

capacities of the valves are 20 to 25% higher than single seated of same sizes. These are balanced valves. These valves are used to direct flow from one of two inlets to a common outlet (mixing) or to direct flow from a common inlet to one or two outlets (Directing). The Two/ Three way control valves shall have Cast Iron, Carbon Steel, Cast Bronze, Stainless Steel body. These valves shall be conforming Cast Iron Carbon Steel & Stainless Steel- and conform to relevant standard. The valve packing shall have Graphite Impregnated Asbestos, Teflon impregnated Asbestos, Teflon. The top & Bottom or Top & Skirt guiding shall be provided. The Two/Three way valves Actuator should be Electrical motor-reversible type, mounted on valves, directly coupled. The valve shall be complete with Thermostat & sensor assembly with control wiring. The Actuator should be suitable for valve action of stay-put. The Actuator shall have hand wheel for manual operation, remote valve position, indication auxiliary switches, feedback Potentiometer. The Actuator should be as per IP-55 enclosure.

53) REPLACEMENT OF DAMAGED THERMAL INSULATION WITH NEW ONE WITH ALUMINUM FOIL TO CHILLED WATER PIPE LINE-

The existing damaged thermal insulation of chilled water pipe line shall be removed. The pipe surface shall be cleaned by removing scales. The Chiller Water pipe line shall be reinsulated by new aluminium foil to chilled water pipe line.

54) SERVICING AND MAINTENANCE CONTRACT FOR WINDOW MODEL AND SPLIT AIR CONDITIONING UNITS:

a) Scope of The Work:-

Successful contractor shall carry out the following works during the contractual period during normal working days in order to maintain the temperature of $74^{\circ}\text{F} \pm 2^{\circ}\text{F}$ $24 \pm 2.0^{\circ}\text{C}$ ($75^{\circ}\text{F} \pm 3^{\circ}\text{F}$) and RH $55 \pm 5\%$ (not controlled) in the Air Conditioned areas. The contractor shall render by monthly services to the window model and split air conditioning units and shall attend break down calls for the units.

b) Works to Be Carried Out In The Bi-Monthly Preventive Maintenance & Services:-

- (i) Checking compressor, Air Conditioning system for leakage, loose contacts etc.
- (ii) Cleaning of condenser coil & evaporator coils with air blower/water jet.
- (iii) Checking all electrical parts of the system servicing & cleaning the electrical contacts.
- (iv) Cleaning of Air filters.
- (v) Checking of all refrigerant line & valves.
- (vi) Checking of all Electrical controls.
- (vii) Checking the temperature in the A C area and record the same.

c) Other Service & Maintenance Terms:-

- (i) The successful contractor shall attend the breakdown of window & split AC units whenever called upon by Municipal authorities within 48 Hours.
- (ii) The contractor shall carry out repairs & overhauling of compressor, fan motor whenever required without any extra charges.

TECHNICAL SPECIFICATIONS M&E

- (iii) The successful contractor shall carry out the replacement of electrical parts/ controls used in the air conditioning units if necessary with no extra charges.
- (iv) The successful contractor shall carry out replacement of suction air filter if necessary without extra charges.
- (v) The successful contractor shall carry out refrigerant charging to the system whenever required.
- (vi) The successful contractor shall carry out painting to all sheet metal parts of the units once during contract period with red oxide primer coat and enamel paint.
- (vii) The successful contractor shall clean the installation site after carrying out any type of work.

d) Other General Terms & Conditions:-

- (i) The successful contractor shall submit 2 copies of their service / breakdown report of unit after periodically servicing, one each to user department.
- (ii) No unit shall remain idle for major repairs for want of refrigerant gas or spare parts for more than (3) three days period.
- (iii) The contractor shall inspect each window AC unit before submission of tender/quotation. If the units are not in working condition due to break down and defects, then contractor shall repair/ replace the same and start the annual maintenance contract of the units. The expenses for this repair/ replace work shall be considered while tendering the offer. No extra payment for any repair/ replacement work will be borne by MCGM.
- (iv) If any preventive bi-monthly service is not rendered during the contract period, the service charges for this period will not be paid on pro-rata basis.

TECHNICAL SPECIFICATIONS M&E

e) Penalty Term :-

(i) In case a window model or split air conditioning unit covered in the service contract remained un-repaired for 30 days or more than 30 days continuously due to failure of major component such as Compressor/ Coil Leakage or due non-availability of any imported spare part, one month service charges for that plant on pro-rata basis of the yearly service and maintenance charges of that plant, will not be paid and thereafter for every successive 30 days un-repaired period one month service charges per 30 days will not be paid. In addition to this, the penalty equivalent to 1/2% per week or part thereof on the monthly service charges of that particular plant will be recovered from the contractor without any reference to the contractor from 31st day of the un-repaired period of the plant. The amount of the penalty will be however subject to the maximum 10% of the monthly service charges for the plant for first 30 days (one month) un-repaired period similarly for further every 30 days period, the penalty as stated above on a monthly service charges deducted for the period will be recovered from 31st day of the every 30 days un-repaired period.

(ii) The successful contractor shall bring their own tools, machinery etc. to carry out the maintenance work.

(iii) The damages if any caused to any other municipal property while carrying out the maintenance work will be recovered from the contractors running bill or security deposit.

(iv) The Contractor shall take necessary safety precautions to avoid any hazard/ accident at site. M.C.G.M. will not be responsible for any hazard / accident taken place to the person of the contractor while carrying out maintenance works.

(v) The service report acknowledged by competent authority of user department shall be treated as valid.

f) Payment:-

The payment shall be preferably made every (4) four month on Pro-rata basis after completion of first two (2) servicing, on receipt of bill and service report copies from the successful contractor.

55) CSMC OF DUCTABLE/ PACKAGED AC UNITS-

- I. The contractor shall carry out the servicing, repairs, maintenance of the units to render trouble free uninterrupted services to the user department as per their requirements.
- II. The contractor shall carry out the servicing of all the plants bi-monthly.
- III. The contractor will carry out the following works during the servicing.
 - a) Cleaning the condenser water cooling system including draining & cleaning of cooling tower, sump, strainer, pot strainer, spray pipes & spray nozzles, Oiling and greasing to fan motor etc. and examining the function of cooling tower for satisfactory performance. Chemical cleaning of fills of cooling tower if required. Noting the water temperatures across the cooling tower.
 - b) The contractor shall clean all the electric contacts for various electrical controls, check the cables terminals for tightness & attend if necessary.

TECHNICAL SPECIFICATIONS M&E

- c) Check the terminal connections of the motor for tightness & lubricate the bearings.
 - d) Inspecting, checking the refrigerant gas & oil in the plant system & top up if required by carrying out necessary leak detection test.
 - e) Cleaning of entire plant externally.
 - f) Cleaning of air filters.
 - g) Checking and adjusting the belt tension & replace belts if necessary.
 - h) Check the working of all the gauges including pressure gauge, ammeter, voltmeters etc. on refrigeration system.
 - i) Check the performance of the plant after servicing.
- IV.** Attend the complaint calls free of cost whenever called by the MCGM.
 - V.** Carry out de-scaling and cleaning of condensers, cooling coils "Half yearly" as per the need or if required early.
 - VI.** Check the compressor oil of A.C. plants while carrying out servicing & replace it if necessary.
 - VII.** The contractor shall replace the spares of all the equipments integrated to the refrigeration systems if found necessary at their cost. The spare parts used shall be genuine, of reputed make.
 - VIII.** Contractor shall carry out servicing / over hauling of all the valves of the refrigeration system of the A.C. plants & check their operation for proper working.
 - IX.** The contractor shall replace torn out/ damaged pre-filters during the contract period.
 - X.** The contractor shall replace the electrical cables in the plant room up to Main control panel if required. Also, the wiring, switches, electrical contacts, bulbs & electric fuses etc. in the main control panel, as per the need shall be replaced.
 - XI.** Check the working of all measuring instruments such as pressure gauges, ammeters, voltmeters, thermometers etc. of the refrigeration systems, attend and replace if defective.
 - XII.** Replace the canvas connections, drip trays, internal or external thermal insulation of Package plant etc if necessary.
 - XIII.** Check the performance of the plant after servicing by noting various operating parameters such as temperature, pressure, control settings etc.
 - XIV.** The contractor shall clean the premises of packaged plant rooms, AHU rooms after carrying servicing. The material, dirt, waste etc. caused during servicing shall not be left in the plant room.
 - XV.** The contractor shall maintain / repair all the electrical motors, starters, switches etc. of plant's higher and lower sides and of package plants etc.
 - XVI.** The contractor shall maintain, repair, replace defective compressors of packaged plants.
 - XVII.** Contractor shall replace fused indicating lamps on the electrical panels of plants.
 - XVIII.** Contractor shall maintain, repair/ replace all the controls in the plant room and shall maintain, repair all the controls provided to supply conditioned air as per users need on lower sides.
 - XIX.** The contractor shall dispose off all the old removed material such as spare parts, lubricating oils etc during servicing & maintenance contract.

TECHNICAL SPECIFICATIONS M&E

Exclusions:

- a. Day to day operations, daily routine maintenance.
- b. Replacement of pressure gauges, thermometers & valves on condenser water pipeline.
- c. Replacement of condenser water pipeline.
- d. Replacement of ducting and its accessories like dampers, grills etc. & all types of thermal & acoustic insulation.

Penalty Terms:-

- (i) In case a ductable or packaged AC unit covered in the service contract remained un-repaired for 30 days or more than 30 days continuously due to failure of major component such as Compressor/ Coil Leakage or due non-availability of any imported spare part, one month service charges for that plant on pro-rata basis of the yearly service and maintenance charges of that plant, will not be paid and thereafter for every successive 30 days un-repaired period one month service charges per 30 days will not be paid. In addition to this, the penalty equivalent to 1/2% per week or part thereof on the monthly service charges of that particular plant will be recovered from the contractor without any reference to the contractor from 31st day of the un-repaired period of the plant. The amount of the penalty will be however subject to the maximum 10% of the monthly service charges for the plant for first 30 days (one month) un-repaired period similarly for further every 30 days period, the penalty as stated above on a monthly service charges deducted for the period will be recovered from 31st day of the every 30 days un-repaired period.
- (ii) The successful contractor shall bring their own tools, machinery etc. to carry out the maintenance work.
- (iii) The damages if any caused to any other municipal property while carrying out the maintenance work will be recovered from the contractors running bill or security deposit.
- (iv) The Contractor shall take necessary safety precautions to avoid any hazard/ accident at site. M.C.G.M. will not be responsible for any hazard / accident taken place to the person of the contractor while carrying out maintenance works.
- (v) The service report acknowledged by competent authority of user department shall be treated as valid.

Payment:-

The payment shall be preferably made every (4) four month on Pro-rata basis after completion of first two (2) servicing, on receipt of bill and service report copies from the successful contractor.

56) CSMC of VRF AC units-

- (i) The contractor shall carry out servicing, repairs and maintenance of VRF/ VRV A.C. Plants to render trouble free uninterrupted services to the user department as per their requirements.
- (ii) The contractor shall carry out the servicing of plant bimonthly.
- (iii) The contractor shall carry out the following works during the servicing.

TECHNICAL SPECIFICATIONS M&E

- a. Cleaning the condenser system, Oiling & greasing to fan motor for satisfactory performance.
 - b) The contractor shall clean all the electric contacts, check the cable termination for tightness & attend if necessary.
 - c) Check the terminal connections of the motor for tightness & lubricate the bearings
 - d) Inspect, check the refrigerant gas & oil in the plant & top up if required after carrying out leak test.
 - e) Cleaning of entire unit externally.
 - f) Attend the calls whenever called by the MCGM free of cost.
 - g) Checking the refrigeration system, motor, starters & ensuring healthy condition of unit.
- (iv) Checking the refrigeration control system for operation and adjusting the settings
 - (v) Replenishment of refrigerant gas as result of fare wear & tear.
 - (vi) Checking the functioning of compressor & its accessories.
 - (vii) Overhauling/ repairing the components of the equipment at site or in service station as and when required including providing stand by compressor for screw/scroll units in case of failure of the compressor, repair /replacement of compressor if found not working.
 - (viii) The contractor shall replace the spares of all the equipments related to the refrigeration system if found necessary at their cost.
 - (ix) The contractor shall paint all equipments, pipes, fittings & panel boards etc. if corrosion occurs for the sheet metal parts.
 - (x) Check the performance of the unit after servicing.
 - (xi) The contractor shall clean the premises after carrying out servicing works. No material, dirt, caused during servicing shall be left in the premises.
 - (xii) The contractor shall maintain / repair all the electrical motors, starters, switches and repair PCB circuits if found faulty.
 - (xiii) Attend all Break-down calls within 48 Hours whenever called upon by Municipal authorities.
 - (xiv) Other General Terms & Conditions:-
 - The successful contractor shall submit 2 copies of their service / breakdown report of V.R.F. units after periodically servicing, one each to user department and other to this office.
 - No V.R.F. unit shall remain idle for major repairs for want of refrigerant gas or spare parts for more than 15 days period.
 - (xv) Penalty Term:-

In case a V.R.F unit covered in the service contract remained unrepaired for 30 days or more than 30 days continuously, one month service charges for that unit on pro-rata basis of the yearly service and maintenance charges of that plant, will not be paid and thereafter for every successive 30 days unrepaired period one month service charges per 30 days will not be paid. In addition to this, the penalty equivalent to 1/2% per week or part thereof on the monthly service charges of that particular plant will be recovered from

TECHNICAL SPECIFICATIONS M&E

the contractor without any reference to the contractor from 31st day of the unrepaired period of the plant. The amount of the penalty will be however subject to the maximum 10% of the monthly service charges for the plant for first 30 days (one month) unrepaired period similarly for further every 30 days period, the penalty as stated above on a monthly service charges deducted for the period will be recovered from 31st day of the every 30 days unrepaired period.

If any preventive bimonthly service is not rendered during the contract period, the service charges for this period will not be paid on prorata basis.

(xvi) Payment :-

The payment shall be preferably made every (4) four month on Pro-rata basis after completion of first two (2) servicing, on receipt of bill and service report copies from the successful contractor.

(xvi) Exclusions:

- Day to day operations, daily routine maintenance and House Keeping.
- Replacement of condenser /cooling / heating coils, sheet metal panel.
- Replacement of ducting and its accessories like dampers, grills etc. and all types of thermal & acoustic insulation, all types of piping and valves, electrical panel, cabling.
- Replacement of electrical main incoming switch/Circuit breaker, PCB's and sub- switch, sub-circuit breaker/ power/control cable, panels.

57) CSMC OF DX AHU / CHILLED WATER AHU/ FCU-

1. The contractor shall carry out servicing, repairs and maintenance of Air Handling Units to render trouble free uninterrupted services to the user department as per their requirements.
2. The contractor shall carry out the servicing of all AHUs bimonthly.
3. The contractor will carry out the following works during the servicing.
 - Cleaning the chilled water coil including draining the condensate water and examining inlet & outlet butterfly valves, three way mixing valve etc. Oiling & greasing to blower & motor, examining the function of units for satisfactory performance. Noting the air & water temperatures across the cooling coils of units.
 - The contractor shall clean all the electric contacts, check the cable termination for tightness & attend if necessary.
 - Check the terminal connections of the motor for tightness & lubricate the bearings
 - Cleaning of entire units externally.
 - Checking and adjusting the belt tension & replace if necessary.
 - The Contractor shall clean the prefilters & microvee filters by pressurized water. The water can be tapped from nearby source. The Contractor shall arrange pressure pumps to pressurize water along with hose pipe & coupling etc. if necessary.
4. Attend the calls whenever called by the MCGM free of cost.

TECHNICAL SPECIFICATIONS M&E

5. Carry out descaling of cooling coils once in a year or as per the need arise.
6. Contractor shall carry out servicing/ overhauling of the valves related to units & checks their operation for proper working.
7. The contractor shall paint units, pipes, fittings & electric panel boards etc. in the plant room once in contract.
8. The contractor shall clean pre-filters in every bimonthly service & replace damaged pre-filters as and when required.
9. Replace the canvas connections, bearings of motor and blower etc. if necessary.
10. Repairs to blower & motor if necessary.
11. Check the performance of the units after servicing.
12. The contractor shall clean the premises of AHU room/ area, after carrying out servicing works. No material, dirt, caused during servicing shall be left in the room.
13. The Contractor shall maintain / repair all electrical motors, starters, switches etc. of units.
14. The Contractor shall replace fused indicating lamps on the electrical panels of units.
15. Exclusions :
 - a) Day to day operations, daily routine maintenance.
 - b) Replacement of pressure gauges, thermometers & valves on chilled waterpipeline.
 - c) Replacement of chilled water pipeline along with thermal insulation.
 - d) Replacement of ducting & its accessories like dampers, grills etc. and all types of thermal & acoustic insulation.
16. Penalty Term :-
 - a) In case a unit covered in the service contract remained unrepaired for 30 days or more than 30 days continuously, one month service charges for that unit will not be paid and thereafter for every successive 30 days unrepaired period one month service charges per 30 days will not be paid. In addition to this, the penalty equivalent to 1/2% per week or part thereof on the monthly service charges of that particular unit will be recovered from the contractor without any reference to the contractor from 31st day of the unrepaired period of the plant. The amount of the penalty will be however subject to the maximum 10% of the monthly service charges for the unit for first 30 days (one month) unrepaired period similarly for further every 30 days period, the penalty as stated above on a monthly service charges deducted for the period will be recovered from 31st day of the every 30 days unrepaired period.
 - b) If any preventive bimonthly service is not rendered during the contract period, the service charges for this period will not be paid.
17. Term of Payment:-

The payment will be made every four months on Pro-rata basis after completion of each four months period, on receipt of bill & service report copies from the successful contractor.

TECHNICAL SPECIFICATIONS M&E

58) CSMC OF CHILLER AC PLANTS-

These works shall be carried out as per following.

1. The contractor shall carry out the servicing, repairs, maintenance of the plants to render trouble free uninterrupted services to the user department as per their requirements.
2. The contractor shall carry out the servicing of all the plants bi-monthly.
3. The contractor will carry out the following works during the servicing.
 - a) Cleaning the condenser water cooling system including draining & cleaning of cooling tower, sump, strainer, pot strainer, spray pipes & spray nozzles, Oiling and greasing to fan motor etc. and examining the function of cooling tower for satisfactory performance. Chemical cleaning of fills of cooling tower if required. Noting the water temperatures across the cooling tower.
 - b) The contractor shall clean all the electric contacts for various electrical controls, related to air conditioning system, check the cables terminals for tightness & attend if necessary.
 - c) Check the terminal connections of the motor for tightness & lubricate the bearings.
 - d) Inspecting, checking the refrigerant gas & oil in the plant system & top up if required by carrying out necessary leak detection test.
 - e) Cleaning of entire plant externally.
 - f) Checking and adjusting the belt tension for all belt driven accessories such as compressors, Air Handling Units (AHU motors), Blower motors of package A.C. Etc. & replace belts if necessary. (For those plants which are along with AHU for maintenance)
 - g) The contractor shall clean all AHU coils, air cooled condenser coils & micro-vee filters in the plenum by water. The pressurized water shall be used for cleaning. The water can be tapped from nearby source. The contractor will arrange pressure pumps to pressurize the water through hose pipe & coupling etc.
4. Attend the complaint calls free of cost whenever called by the MCGM.
5. Carry out dis-scaling of condensers, AHU/FCU cooling coils "Half yearly" as per the need or if required early.
6. Carrying out replacement of compressor oil of A.C. plants whenever required.
7. The contractor shall replace the spares of all the equipments integrated to the refrigeration systems if found necessary at their cost. The spare parts used shall be genuine, of reputed make.
8. Contractor shall carry out servicing / over hauling of all the valves of the refrigeration system of the A.C. plants & check their operation for proper working.
9. The contractor shall paint all equipments, pipes, fittings & panel boards etc. if corrosion occurs for the sheet metal parts.
10. The contractor shall replace torn out/ damaged pre-filters as when required during the contract period. The contractor shall replace the electrical cables in the plant room up to Main control panel if required. Also, the wiring, switches,

TECHNICAL SPECIFICATIONS M&E

electrical contacts, bulbs & electric fuses etc. in the main control panel, as per the need shall be replaced.

11. Check the working of all measuring instruments such as pressure gauges, ammeters, voltmeters, thermometers etc. of the main refrigeration plant only, attend and replace if defective.
12. Replace the canvas connections, drip trays, internal or external thermal insulation, blower, blower shaft, bearings, blower of AHU and Package plant etc. if necessary.
13. The contractor shall clean the premises of plant rooms, AHU rooms after carrying servicing. The material, dirt, waste etc. caused during servicing shall not be left in the plant / AHU room.
14. The contractor shall maintain / repair all the electrical motors, starters, switches etc. of plant's higher and lower sides and of package plants etc. (For those plants which are with AHUs and without AHUs only)
15. The contractor shall maintain, repair compressors of Central Air-conditioning plants by replacing defective worn out parts as and when required and also shall maintain, repair, replace defective compressors of AC plants and other units.
16. Contractor shall replace fused indicating lamps on the electrical panels of plants & A.H.U.s.
18. Contractor shall maintain, repair/ replace all the controls in the plant room and shall maintain, repair all the controls provided to supply conditioned air as per users need on lower sides.
19. The contractor shall dispose off all the old removed material such as spare parts, lubricating oils etc. during servicing & maintenance contract.
18. Exclusions :
 - Day to day operations, daily routine maintenance.
 - Replacement of pressure gauges, thermometers & valves on condenser water pipeline and chilled water pipeline excluding main A.C. plant.
 - Replacement of condenser water pipeline & chilled water pipeline along with thermal insulation and different types of valves of these pipelines.
 - Replacement of ducting and its accessories like dampers, grills etc. & all types of thermal & acoustic insulation.
 - Shifting and reallocation of these plants.
19. Penalty Term :-
 - a) In case a plant covered in the service contract remained unrepaired for 30 days or more than 30 days continuously, one month service charges for that unit will not be paid and thereafter for every successive 30 days unrepaired period one month service charges per 30 days will not be paid. In addition to this, the penalty equivalent to 1/2% per week or part thereof on the monthly service charges of that particular unit will be recovered from the contractor without any reference to the contractor from 31st day of the unrepaired period of the plant. The amount of the penalty will be however subject to the maximum 10% of the monthly service charges for the unit for first 30 days (one month) unrepaired

TECHNICAL SPECIFICATIONS M&E

period similarly for further every 30 days period, the penalty as stated above on a monthly service charges deducted for the period will be recovered from 31st day of the every 30 days unrepaired period.

b) If any preventive bimonthly service is not rendered during the contract period, the service charges for this period will not be paid.

20. Term of Payment:-

The payment will be made every four months on Pro-rata basis after completion of each four months period, on receipt of bill & service report copies from the successful contractor.

59) CSMC OF REFRIGERATION UNITS OF WALK IN COOLER/ MORTUARY-

These works shall be carried out as per following.

1. The contractor shall carry out the servicing, repairs, maintenance of the Refrigeration units of walk in cooler/ mortuary to render trouble free uninterrupted services to the user department as per their requirements.
2. The contractor shall carry out the servicing of all the units bi-monthly.
3. The contractor will carry out the following works during the servicing.
 - a) The contractor shall clean all the electric contacts for various electrical controls, related to air conditioning system, check the cables terminals for tightness & attend if necessary.
 - b) Inspecting, checking the refrigerant gas top up if required by carrying out necessary leak detection test.
 - e) Cleaning of entire unit externally.
4. Attend the complaint calls free of cost whenever called by the MCGM.
5. Carry out dis-scaling of condensers, cooling coils "Half yearly" as per the need or if required early.
6. Carrying out replacement of compressor oil of A.C. units whenever required.
7. The contractor shall replace the spares of all the equipments integrated to the refrigeration systems if found necessary at their cost. The spare parts used shall be genuine, of reputed make.
8. Contractor shall carry out servicing / over hauling of all the valves of the refrigeration system of the A.C. plants & check their operation for proper working.
9. The contractor shall paint all equipments, pipes, fittings & panel boards etc. if corrosion occurs for the sheet metal parts.
10. The contractor shall clean the premises of AC units after carrying servicing. The material, dirt, waste etc. caused during servicing shall not be left near AC unit.
11. The contractor shall maintain, repair compressors of Refrigeration units by replacing defective worn out parts as and when required and also shall maintain, repair, replace defective compressors of AC units.
12. Contractor shall replace fused indicating lamps on the electrical panels of AC units.
13. The contractor shall dispose off all the old removed material such as spare parts, lubricating oils etc. during servicing & maintenance contract.

TECHNICAL SPECIFICATIONS M&E

14. Exclusions :

- Day to day operations, daily routine maintenance.
- Replacement of refrigerant pipeline along with thermal insulation.
- Shifting and reallocation of these units.

15. Penalty Term :-

a) In case a unit covered in the service contract remained unrepaired for 30 days or more than 30 days continuously, one month service charges for that unit will not be paid and thereafter for every successive 30 days unrepaired period one month service charges per 30 days will not be paid. In addition to this, the penalty equivalent to 1/2% per week or part thereof on the monthly service charges of that particular unit will be recovered from the contractor without any reference to the contractor from 31st day of the unrepaired period of the plant. The amount of the penalty will be however subject to the maximum 10% of the monthly service charges for the unit for first 30 days (one month) unrepaired period similarly for further every 30 days period, the penalty as stated above on a monthly service charges deducted for the period will be recovered from 31st day of the every 30 days unrepaired period.

b) If any preventive bimonthly service is not rendered during the contract period, the service charges for this period will not be paid.

16. Term of Payment:-

The payment will be made every four months on Pro-rata basis after completion of each four months period, on receipt of bill & service report copies from the successful contractor.

60) CANVAS CONNECTIONS-

The successful contractor shall carry out installation of new Canvas Connections for AHU. The Canvas connection is made up of fabric and desired pressure rating to cater desired CFM.



CANVAS CONNECTIONS

61) VERTICAL LAMINAR AIR DISTRIBUTION CEILING-

- Design, supply, and installation, testing & commissioning of the Vertical laminar air distribution ceiling (surgical module) suitable for Operating Theater rooms.
- The overall system design shall meet the following conditions (at rest and w/o medical equipment).

TECHNICAL SPECIFICATIONS M&E

- Total fresh air supply from top side (multiple openings required)
- Installed HEPA filters class must be H 14 minimum Gel seal with double sided protection grid.
- Average bacteria count shall not be more than 10 cfu/m³.
- Average particle counts on 0.5micron and larger shall not be more than 100 counts per cubic feet.
- The module shall be able to install into false ceiling and individual ceiling system variants. Filter housing of LFU will be tightly welded, mounted in a frame of extruded aluminum profile; the circumferential groove of aluminum extrusion enables connections of ceiling cassettes. The space between the filter housing will be covered by antibacterial powder coated galvanized sheets. All joints are filled by silicone sealant.
- Allowances shall be made for the operating lamp and/or other ceiling mounted pendants to be neatly integrated into the chamber and penetrate the lamina riser.
- The system, supplied with the recommended air flow volume, has in the clean area underneath the filtering ceiling, in Operational Simulated testing conditions.
- The LFU shall have a Plenum of welded airtight housing made of antibacterial powder coated aluminum.
- The positive pressure shall be maintained inside the OT to prevent contamination due to air from outside the OT.
- Material: Al alloy and galvanized steel, powder coated in the color to match the color shade of ceiling. The air distributor shall be made of double micrographic texture with covering frame made of aluminum extrusion for cleaning and disinfectant.
- The HEPA filter for the surgical module shall be replaced from within the room. The HEPA filter shall have a minimum efficiency on MPPS (0.1 to 0.3 micron) of 99.999%. The filter shall of rigid metal frame construction.
- Allowances shall be made for the operating lamp and/or other ceiling mounted pendants to be neatly integrated into the chamber and penetrate the laminar riser.
- Size 1) 2060mmx980mm (+-100 mm) or
2) 2550mmx1380mm (+-100 mm)
- The Plenum will be insulated with 19mm Al Foil Faced Nitrile Rubber.

62) G.I. POWDER COATED RECTANGULAR RISER-

Aluminium duct riser of 18 gauge of size 750x100x3000mm length (+-50 mm), 13 mm Nitrile Rubber Insulation (with Al Foil Faced). SS 304 perforated grill, 4 Nos Aluminum Risers shall be installed on four Corners of the Each Operation Theatre which shall be Insulated with 9mm Nitrile Rubber Insulation which shall have Al Foil Faced. This Duct will be connected to Main Return air duct to exhaust the Air to Atmosphere through the AHU in the AHU Room. GI Main Duct will be running above the False Ceiling of the Operation Theatre. In case of Inbuilt Riser in the Partition Panel, supplier to provide the Return Air Riser as required as per site condition. The necessary drawing with details of Filter fixing and other necessary

TECHNICAL SPECIFICATIONS M&E

arrangement must be submitted before manufacturing. Supply and Installation of Differential Pressure Transmitter connected to pressure port of integrated inlet ring along with control wiring.

63) FLEXIBLE BELLOW FOR CHILLER, CHILLED WATER & CONDENSER WATER PUMPS –

The successful contractor shall supply & installation of Flexible Bellow for Chiller, Chilled Water & Condenser water Pumps of suitable size and reputed make.

64) 50 MM/ 80 MM PPGI SHEET PANEL -

Standard wall partitions are a composite construction of two skins of PPGI/PPGI over a GI frame work with a sealed and insulated interior. Standard panel dimensions are 1200 x 2600mm. Standard panels have an overall thickness of 50 / 80 (± 5 mm). Additional wall heights can be achieved using a stacking technique. The self-supporting internal walls are constructed with an interior Aluminium frame work. Partition to Partition connections are maintained with precision with aluminium profiles that create uniform seams. The Partition seams are sealed by silicone with a perfectly flush finishing. PUF insulation material is sandwiched between the two skin layers and sealed from the exterior by the aluminum frame work. Self-supporting wall provided in modular units consisting of external skin in PPGI/ PPGI which will be 0.6mm thick with protective film to prevent surface damage during shipping and installation. Every panel to be provided with 25mm PVC conduits. Movable wall includes: a) PUF insulation 36 to 40 Kg/m³ b) GI frame work. c) Silicon sealant (Clear, White, Winsil Gray).

65) 60 MM THK PP/SS WITH PUF DOOR-

The insulation of the panels forming cold storage room of the mortuary chamber shall be of 60 mm thickness, by polyurethane of best quality. The polyurethane shall be foamed in place between the external & internal Sheets. The process employed shall be most modern and automatic through sophisticated foaming machine to achieve the chemical & physical mixing process of foaming in place. The polyurethane used shall have a density of 40 Kg / Cu M(+ 2 kg./Cu./M.) The successful contractor shall install cold room for diet section. The insulated panels sections shall be provided with tongue & groove design to enable minimize ingress of moisture between joints and enable extremely fast assembly with the help of CAM operated locks. An expanded polyethylene layer shall be provided on the interior and exterior of each panel to safeguard against transit damages. The cold storage room shall be of double walled construction & made up of prefabricated panels which can be easily locked in position on site. The exterior back & side walls shall be of pre painted 0.5mm thick GI sheet & all the interior walls shall be 0.5mm thick stainless steel sheet of SS 304 grade in standard widths and to facilitate fast and easy assembly at the site. The processing of the inner S.S. sheet forming the panel shall be done with the help of computerized numerically controlled machines and shall give an accuracy of up to 1 mm, so that the total room size is accurately

TECHNICAL SPECIFICATIONS M&E

controlled, also the joints between panels are uniform. The panels shall be fabricated and assembled in such manner that perfect alignment and maximum strength are ensured. For each corner 90° angled panels of one piece construction shall be provided and the circular horizontal dimensions of each side of the corner shall be 300 mm. Tongue and groove joints shall run throughout the four sides of the panel. The cam locks shall be provided on the wall panels. The entrance door body shall be fabricated out of 0.5 mm thick SS 304 grade stainless steel sheet for exterior & interior side. The door shall be of in fitting flush mounted type. A thermoplastic gasket with a magnetic steel core shall be on and along the top edge, side and bottom of the door section. The gaskets shall be easily replaceable. The door shall have hinges made up of Chrome plated Aluminium Zinc alloy material and shall be of self closing. The latch shall be so designed to easily open the door by breaking the magnetic force of the door gaskets. The latch shall have a cylinder type lock and shall be equipped with an inside safety release handle to take care of anyone from being locked in accidentally.

66) KOTA FLOORING-

To provide new thermal insulation to floor with 60 mm thickness polyurethane slabs finished with layer of P.C.C. and with kota tiles. The polyurethane used shall have a density of 40 Kg / Cu M (+ 2 kg /Cu/M) To provide machine cut Kota tiles with proper jointing on flooring. After fixing the tiles the same shall be machine polished. The Kota tiles shall be of good quality, uniform colour for whole work and smooth machine polished having absolute even surface. Tiles with uneven surface shall not be used.

67) SS RACKS-

Racks shall be designed to utilize maximum space for storage of medicine boxes/ bodies. Rack systems incorporating following items as per the requirements of SS Body Rack systems. The Rack design should be robust considering longer duration for keeping the medicine boxes/ bodies.

- i) Length shall be minimum 2 x 4 feet.
- ii) There shall be three/ four levels as per user requirement.

68) CIRCULAR CHART RECORDER-

Wall mounted seven days graphic temperature recorder with pen recording mechanism along with chart shall be provided. It shall be micro controller based unit & motor driven pen & chart movement. Input shall be universal (PT 100 sensor, all type thermocouple, V DC & mA). Cabinet shall be powder coated. Display shall be alphanumeric LCD display with backlit.

69) MOTORISED VOLUME CONTROL DAMPER-

Dampers shall be multi blade type with opposed blades or parallel blades of aerofoil extruded Al construction rotating in permanently lubricated ball/roller or Teflon sleeve bearings. Blades shall be 150 mm (6") max. width and 1200 mm (48") maximum length mounted in a 50 mm (2") channel frame. Blades shall be

TECHNICAL SPECIFICATIONS M&E

connected with suitable linkages/gears for gang operation by an operating rod. Motorized Dampers shall have extended Stem to mount the Actuator.



MOTORISED VOLUME CONTROL DAMPER

70) MS STANDS FOR VRF / DUCTABLE / PACKAGE AC OUTDOOR UNITS-

The outdoor units of VRF / Ductable / Package AC units shall be installed on M.S. Angle Iron stand and bracket. M.S. Angle from stand and bracket made of M.S. angle iron of size 50 mm X 50 mm. X 6 mm. as stiffener & middle supporting flats bars (Minimum 3 supports) of size 50 mm X 6 mm, to withstand the load of outdoor unit, with platform at suitable level. The stand brackets shall be fixed to wall with suitable sized anchor fastener. To avoid vibration and metal to metal contact, a serrated rubber pads shall be provided between the base of the unit and M.S. Stand. M.S. stands shall be painted in approved manner.

71) CUBICAL PANEL FOR CHILLED WATER AHU/ REFRIGERATION UNIT-

Supply, installation, testing and commissioning sub-panel (cubical type) for air handling unit/ Refrigeration unit for walk in cooler/ mortuary as complete with earthing interconnections, 4 C X 2.5 Sq.mm / 3 C X 1.5 Sq. mm copper armored cable with earthing, gland packing & end termination, etc. and basically comprising suitable TPN switch fuse units with HRC fuses fully automatic DOL/Star delta starter for the fan motor, ammeter, indicating lamp etc. The panel shall be mounted by means of 6mm x 150mm long rage bolts grouted in the wall and provided with washers and nuts. The panel shall be fabricated from 16 SWG sheet plates welded or folded construction duly painted & shall be comprising of panel mounted push buttons (ON/OFF) type and indicating lamps.

72) CONTROL PANEL FOR DX AHU/ PACKAGED/ PRECISION AC UNITS-

The electrical panel shall be powder coated and fabricated out of 16 gauge GI sheet. Panel shall have main supply switch (L&T/ Siemens make) and MCB's as per desired ratings for packaged plants, complete with tinned copper bus-bars, LED indicating lamps, digital ammeter, digital voltmeter, termination box, interconnecting cables, control wiring in copper. The panel shall be installed in the Plant room.

TECHNICAL SPECIFICATIONS M&E

73) TIMER FOR AC UNITS-

Timer suitable for working on single phase 230 V supply for Ductable / split AC for working and standby of 8 / 12 hours, it should be with temperature sensor in order to prevent shutting of break down machines. Single machine or both machine shall start if temperature falls below set point. Working should be based on NONC contacts.

74) ALUMINIUM CLADDING-

Supply and installation of aluminium cladding on Chilled water piping with 26 G GI sheet, it shall be with proper grooves and screwed in order to have even finished surface. Joints shall be made properly in order to avoid blunt edges.

75) MS STRUCTURE –

As per the site condition platform shall be used for any type of air conditioning unit as suggested by civil consultant/site in charge. ISMB, ISA, M.S. Plate along with accessories shall be used for making platform. The size of platform shall be as per actual size of AC units.

76) FRP COATING-

FRP coating shall be made to M.S. structure and other accessories as per standard practice. Before FRP coating the ms structure shall be properly scrapped with the help of grinder & the same shall be made free from dust, rust, scale, oil & grease. Then the proper mixture of resin liquid & hardener shall be applied on the ms structure. The chopped mats of glass wool & resin shall be applied on the ms pipeline. Such type of minimum two coats shall be applied. Finally, the outer surface shall be properly finished with mixture of resin & hardener with yellow color shade.

77) VALIDATION-

Validation of laminar flow shall consist of Air Balancing of AC System, ACPH/ Return CFM/Fresh air, humidity, Temp Monitoring for Continuous 3 days. Tenderer to follow the Clients protocol to carry out the validation of the Systems. Blow down of AHU will be part of validation scope.

78) TO MAKE OPENING IN THE WALLS-

The successful tenderer shall make openings in the walls of rooms for laying of refrigerant piping /drain piping, cabling, ducting etc. and making them good including finishing with sand cement plaster.

79) PAINT FOR EXPOSED DUCTS-

The successful tenderer shall properly cleaned degreased pickled phosphated and applied with one coat of anti-corrosive red oxide and 2 coats of synthetic enamelled paint of approved make and shade. If the surrounding atmosphere is corrosive, the finishing paint shall be corrosion resistant for the type of atmosphere.

TECHNICAL SPECIFICATIONS M&E

80) INSTALLATION, TESTING AND COMMISSIONING OF SPLIT AC UNIT, DUCTABLE/ PACKAGED/ PRECISION AC UNIT-

The successful tenderer shall carry out flushing with nitrogen & then vacuumed the whole system after successful installation of AC units. The pressure testing shall be carried out by filling the nitrogen. If any leakages found the same shall be attended & rectified. After that the whole system shall be commissioned.

81) SITC OF AIR CURTAIN-

The successful contractor shall supply & install of air curtain as per size 36"/ 48"/60"/ 72" required. SITC of Providing Air Curtain with medium speed, low noise blowers suitable for single phase AC supply & complete with 1 mtr cable with switch socket connection. Make - Russel, Euronics and reputed make.

82) DISMANTLING OLD PRECISION AC UNITS AND ITS ACCESSORIES

The existing worn out Precision AC Unit, its all accessories (related to air conditioning) in sections shall be removed as per the instructions of the site engineer and stored as directed by hospital authorities. While removing the material the care shall be taken so that no damage to nearby equipment and municipal properties will be caused.

83) DISMANTLING OLD AIR HANDLING UNIT AND ITS ACCESSORIES

The existing worn out Air Handling Unit, its supply air ducting, and chiller pipeline, valves, false ceiling, thermal insulation etc. in the AHU room and all accessories (related to air conditioning) in sections shall be removed as per the instructions of the site engineer and stored as directed by hospital authorities. While removing the material the care shall be taken so that no damage to nearby equipment and municipal properties will be caused.

84) DISMANTLING OLD CHILLER PLANTS AND ITS ACCESSORIES

The existing worn out Chiller unit/ plant, its all accessories (related to air conditioning) in sections shall be removed as per the instructions of the site engineer and stored as directed by hospital authorities. While removing the material the care shall be taken so that no damage to nearby equipment and municipal properties will be caused.

85) REBATE FOR OLD CHILLER PLANTS AND ITS ACCESSORIES

The contractor shall take away the dismantled Chiller plant/ unit, its all accessories also and all the removed old material and shall offer rebate for the same. It is also contractor's responsibility to dispose off all the removed material of thermal insulation, false ceiling sheets & debris generated during this work. The contractor shall offer rebate as mentioned or more for the above material per one Chiller unit.

86) REBATE FOR OLD DX AHU AND ITS ACCESSORIES

The contractor shall take away the dismantled AHU, its all accessories also and all the removed old material and shall offer rebate for the same. It is also contractor's

TECHNICAL SPECIFICATIONS M&E

responsibility to dispose off all the removed material of thermal insulation, false ceiling sheets & debris generated during this work. The contractor shall offer rebate as mentioned or more for the above material per one AHU.

87) REBATE FOR OLD CEILING SUSPENDED/ FLOOR MOUNTED AHU AND ITS ACCESSORIES

The contractor shall take away the dismantled AHU, it's all accessories also and all the removed old material and shall offer rebate for the same. It is also contractor's responsibility to dispose off all the removed material of thermal insulation, false ceiling sheets & debris generated during this work. The contractor shall offer rebate as mentioned or more for the above material per one AHU.

SP-ME-TS- 64 : FIRE FIGHTING SYSTEM

Fire safety in building has become very important consideration in Installation and maintenance. A normal office building has fire load in the form of large quantity of papers and furnishing. Buildings like Hospitals, Laboratories, Auditorium, Libraries, and Museum etc. require fire safety provisions by virtue of their type of occupancy and importance irrespective of their height. The design and installation of a fire fighting system is of utmost importance. The fire fighting installation on completion will have to be got cleared from the local fire fighting authorities (Fire Service) for its efficacy, suitability and usability by the Fire Service in the event of a fire.

Following types of water based fixed fire fighting installations are normally provided in buildings:

Wet Riser.

Down Comer.

First aid Hose Reel

Yard

Hydrant

Automatic Sprinkler.

The design of fire fighting system for a building shall base as per the provisions in National Building Code of India (Part IV) 2016 and also considering the provisions in the Development Control Rules of local body/authority.

The operating pressure of individual hydrant shall be between 5.5 kg/cm² to 3.5 kg/cm and the operating pressure of the furthest level hydrant from main pump shall be minimum 3.5 kg/cm.

The pipeline shall be designed in such a way that it should be possible to get discharge at any desired location.

A) Technical Specifications of Pumps:

This part deals with the specifications of following pumps

1.Main Fire Pumps (Single Stage) /(Multi Stage)

2, Jockey Pumps

3.. Booster Pumps

Scope:

Supplying, Installing, testing, perfect aligning, proper levelling and commissioning of Fire service main/Jockey/booster pump, Single/multi stage having specified discharge and head with required HP or similar to with minimum parameters, confirming to IS: 12469 with specified size of suction and delivery pipes, coupled with squirrel cage A.C. induction motor. The pump set shall be installed on cement concrete foundation with base frame with proper alignment. The Main Fire pumps should be able to deliver minimum operating pressure of 3.5 kg/cm² at highest and farthest hydrant.

TECHNICAL SPECIFICATIONS M&E

Selection of Main Fire Pumps (Single & Multi Stage Centrifugal type), Jockey Pump (Centrifugal type) & Booster Pump (Centrifugal type) shall be as per Table below

Material:.

Pump Body:

The centrifugal pumps shall conform IS to 1520. The pump casing shall be of heavy section close grained cast iron and designed to withstand 1.5 times the working pressure. The casing shall be provided with shaft seal arrangement as well as flanges for suction and delivery pipe connections as required.

Impeller –

The impeller shall be bronze. This shall be shrouded type with machined collars. Wear rings, where fitted to the impeller, shall be of the same material as the impeller. The impeller surface shall be smooth finished for minimum frictional loss. The impeller shall be secured to the shaft by a key. -

Shaft:

The shaft shall be of stainless steel EN-8/ C - 40 and shall be accurately machined. The shaft shall be balanced to avoid vibration at any speed within 'the operating range of the pump

Shaft Sleeve:

The shaft sleeve shall be of bronze.

Bearing:

The bearing shall be of stainless steel and of ball or roller type suitable for duty, involved. These shall be grease 'lubricated and shall be provided with grease nipples /cups. The bearings shall be effectively sealed against leakage of lubricant or entry of dust or water.

Shaft seal: -

The shaft seal shall be mechanical type so as to allow inimum leakage. A drip well shall be provided beneath the seal.

Motor,

Suitable HP squirrel cage induction 'motor, TEFC (totally enclosed fan cooled) synchronous speed 3000 RPM, suitable for operation on 415 volts, 3 phase 50 Hz. AC with IP 55 protection for enclosure, horizontal foot mounted type with Class-'F' .insulation, conforming to IS-325.

Body: Cast iron

Rotor Shaft: Stainless steel

Bearing: Refer specification for bearing under Pump above.

Winding: Class 'F' insulated copper winding.

Base plate: Fabricated from Mild Steel, foundation bolts etc.

TECHNICAL SPECIFICATIONS M&E

Cement Concrete Foundation: Cement, Sand, and Water, in 1 :2:4 ratio.

Anii Vibrating Pads: Made from high quality rubber of specified grade and strength.

Hardware: Mild Steel

Method of Installation:

The surface of the pump foundation should be chipped with ~~pneumatic hammer~~ or sharp pointed chisel. The teak wood box of appropriate size shall be placed and filled with cement concrete in 1 :2:4 ratio with 20 to 25 mm stone metal and required size and strength of foundation nut & bolts. The necessary curing & finishing shall be done in approved manner. The M.S. fabricated base plate of suitable size & strength should be fixed with anti- vibration rubber pads. Proper levelling and alignment shall be observed before tightening of foundation bolts. Both the pump and motor shall be placed on common base 'plate frame with perfect alignment, proper levelling. The pump should be connected to' pipe line with M.S. flanges, gaskets, nut bolt etc and shall be checked for the leakages. The coupling guard shall be provided with nut bolts of required size. The pump shall be tested for 3.5 kg/cm² pressure at highest and farthest point of the building for minimum 2 hours. The necessary test certificate from manufacturer of pump and motor shall be produced. The motor should have efficiency more than 90% and power factor above 0.80.

Fire Fighting Pump Single/ Multi stage Centrifugal :-

LPM	Head in Mtr.	Sunction/Delivery size in mm
1620	56	150/125, 125/100, 100/65, 80/65
2280	70	125/100. 100/80
2820	70	150/125,125/100
2820	88	150/125,125/100
4560	70	200/150, 150/125
6840	105	200/150



Fire Fighting Pump Single/ Multi stage Centrifugal

TECHNICAL SPECIFICATIONS M&E

Jockey Pump (Centrifugal Type)

LPM	Head in Mtr.	Suction/Delivery size in mm
240	56	50/32
240	70	50/32
240	83	50/32
240	105	50/32



Jockey Pump

Booster Pump Centrifugal type-

LPM	Head in Mtr.	Suction/Delivery size in mm
450	70	50/32
450	88	50/32
450	35	50/32
468	40	50/32

TECHNICAL SPECIFICATIONS M&E

Values listed in table are for reference, however details of pumps shall be as per site condition and its availability in market.



Booster Pump Centrifugal type

B) PIPES

Scope:

Supplying erecting ISI mark pipes of specified diameter with necessary fittings such as sockets, elbows, bends, tees, reducers, enlarger, plugs, etc. fixing with clamps & all related works such as excavation, drilling holes in wall, slabs, backfilling & making good the damages.

Following IS codes shall generally be referred for installation of pipe/ fittings etc. The details are as under:-

a) Cast Iron (CI) Pipes

1. Horizontally Cast Iron pipes IS -7181
2. Vertically cast Iron pipes IS 1537
3. Centrifugally cast (spun) IS 1536 iron pipes
4. Centrifugally cast (Spun) iron class "A" pipes with Tylon joints confirming to IS 1536 :1976 or MS/GI (confirming to IS 1239 (part 1): 1979] , in which case it should be properly treated with a coat of primary paint with two coats of bitumen paint or wrapped as IS 10221



CI Pipe

TECHNICAL SPECIFICATIONS M&E

b) Mild Steel (MS) pipes-

1. Wrought or mild steel pipes(galvanized or not) of heavy grade confirming to IS 1239 (part 1) and IS 1978 (when installed underground or electric resistance welded steel pipes confirming to IS 3589 having welded joints and coated and wrapped as per IS 10221
2. Mild steel confirming to IS 3589:1981
3. Mild steel pipes conform to IS 1239 (part2): 1982



Mild Steel (MS) pipes-

c) Galvanized Iron (GI) pipes-

The pipes should be galvanised , medium grade complying with IS 1239 (Part 1) : 1979 and therein fittings should be according to IS 1239 (part 2) 1982

Method of Installation:

Galvanized iron MS /GI pipes of specified diameter and type and fittings shall be erected on MS angle support with one coat of red oxide primer and two coats of Post Office fire red enamel paint duly tested to 1.5 times of working pressure. Excavating and back filling trenches including dewatering, cutting through walls, floor, etc., and making site good. No joint shall be *located* in the thickness of the walls. *If* the pipe is required to be cut, the burns of the cut end shall be filled smooth and any obstruction in the bore shall be entirely eliminated. The rate includes wastage in cutting etc. When the pipe is to be fixed to walls it shall be fixed with standard bracket, clips or *holder* bates keeping the pipe about 12mm clear of the wall. The pipe shall be fixed to the wall horizontally and vertically and parallel to one another when more than one pipe is *laid unless* unavoidable. The supporting clips, etc., for the pipe shall be spaced at about two meters or so as necessary. When holes are not left during Installation they shall be cut into the walls or slabs, etc., to pass the pipe through or to fix clamps. etc., after fixing of the pipes, clamps etc., these shall be *neatly* made good. Laying, jointing, and fixing the pipe with the fittings including cutting pipes, wastage and threading the ends. At all the road crossings the pipes shall be laid lower than the crust of the road. During excavation if, any other service pipes (Water, electric, telephone, etc) come across, these shall be carefully protected and supported. Any damages done shall be made

TECHNICAL SPECIFICATIONS M&E

good. The pipe shall be laid on a well compacted bed in the trench. The trench after laying the pipe shall be refilled except at the joints in layers and manually rammed. Care shall be taken to see that no earth, etc., gets inside the pipes. The filling shall be kept raised by about 5 cm. for subsequent settlement. Bedding and cushioning of murum, good earth, or sand shall be provided for the pipe in case of trench through rock. The trench at the joints shall be filled similarly after satisfactory testing of the pipe. Any surplus excavated stuff shall be disposed of satisfactorily without causing nuisance.



Galvanized Iron (GI) pipes-

Anti Corrosive Protection On Under Ground Pipe -:

Corrosion protection tape shall be wrapped on M.S. Pipes to be buried in ground. This corrosion protection tape shall comprise of coat tar/asphalt component supported on fabric of organic or inorganic fiber and minimum 4 mm. thick and conform to requirement of IS: 10221-Code of practice for coating and wrapping of underground mild steel pipe line. Before application of corrosion protection tape, all foreign matter on pipe shall be removed with the help of wire brush and suitable primer shall be applied over the pipe thereafter. The primer shall be allowed to dry until the 'solvent evaporates and the surface becomes tacky. Both primer and tape shall be furnished by the same manufacturer. Corrosion protection tape shall then be wound around the pipe in spiral fashion and bounded completely to the pipe. There shall be no air pocket or bubble beneath the tape. The overlaps shall be 15 mm.' and 250 mm. shall be left uncoated on either end of pipe to Permit installation and welding. This area shall be coated and wrapped after the pipe line is installed.

The tapes shall be wrapped in accordance with the manufacturer's recommendations. If application is done in cold weather, the surface of the pipe shall be pre-heated until it is warm to touch and traces of moisture are removed and then primer shall be applied and allowed to dry.

Pressure Testing:

All piping shall be tested to hydrostatic test pressure of at *least* one and a *half* times the maximum operating pressure, but not *less* than 10 kg/cm² for a period not *less* than 24 hours. All *leaks* and defects in joints *revealed* during the testing shall be rectified to the satisfaction of the Engineer-in-Charge. Piping repaired subsequent to the above pressure test shall be re-tested in the same manner. System may be tested in sections and 'such

TECHNICAL SPECIFICATIONS M&E

sections shall be *securely* capped. Pressure gauges may be capped off during pressure testing of the installation.



Pressure Testing:

C) VALVES

a) FOOT VALVES WITH STARINER (-VE SUCTION)

Supplying and Installing cast iron foot valve of specified diameter with strainer confirming to IS 4038 with Gun metal seat , nut bolts, gaskets, washers etc. for negative suction.

Material:

Housing;| Seat\discs\ disc plates: Grey cast iron

Hinge 'pins and disc-'guide:' high tensile Stainless Steel bars'

Strainers: a) Grey cast iron, b) Galvanized-steel'

Disc faces: a) Vegetable tanned leather (Min. 3 mm. thick), b) Leaded tin bronze, c) Natural rubber (with reinforcement: of cotton canvas), d) Synthetic- rubber (with reinforcement of cotton canvas)

Flange jointing nature: :a) Compressed fibre board or rubber min 1,5 mm thick. The fibre board shall be impregnated with chemically neutral oil and shall have a smooth and hard-surface. b) Compressed asbestos fibre.

Method of Installation:

The foot valve with strainer shall be fitted with flange, gaskets, nut bolts etc and shall be positioned at required location and fitted firmly to pipe with proper alignment so as the joints should be leak proof with shellac and other material required including necessary labour and tools and plants.



FOOT VALVES WITH STARINER (-VE SUCTION)

b) End Line strainer (+ve suction)

Scope:

Supplying and installing end line strainer of specified diameter as per IS 907, fabricated out of brass perforated sheet of 14 SWG (2:0 mm. thick) duly' with brazing to flange or,pipe, with nut bolts;-gaskets, 'Washers etc; in position for only suction in an approved manner.

Material:

Body: Cast Iron

Strainer Screen: stainless steel/ Brass screen of 1mm thick perforated sheet with 3 mm diameter holes.

Method of Installation:

, End line strainer with strainer shall be fitted with provided flange, gaskets, nut bolts etc, and to be erected at the end of suction pipe, including labour and required tools and plants.



End Line strainer (+ve suction)

TECHNICAL SPECIFICATIONS M&E

c) Sluice Valve

Scope:

Supplying and installing cast iron double flange sluice valve of specified diameter conforming to IS: 14846, ISI mark, having cast iron body and gun metal working parts with nut bolts, gaskets etc. and tested to 1.5 times of working pressure, in an approved manner. Gate valve, in smaller sizes (50NB), shall be all bronze and confirming to IS:778 with screwed ends.

Material:

Body: a) Brass, b) Leaded tin bronze

Bonnet or cover: a) Leaded tin bronze, b) Forged brass, c) Brass Stuffing box, disc hinge, check nut, stem nut, disc retaining nut, gland, gland

nut, gland flange, body seat rings and disc or wedge facing rings (where renewable): a) Leaded tin bronze, b) Extruded brass rod, c) Forged brass, d) Brass

Stem, hinge pin and plug: a) Extruded brass rod, b) High-tensile brass, c) Forged Brass *Ball (for ball type check valves):* Chromium steel *Nut bolts:* Mild steel

Hand wheel: Cast iron

Gasket: Compressed asbestos fibre

Gland packing: a) Hemp and jute, b) Asbestos

Spring: Phosphor bronze wire

Seating ring: Synthetic rubber

Method of Installation:

The double flange sluice valve shall be fitted with flange, gaskets, Nut bolts, etc. to be fitted to pipe, accessories with washers, spring washers, check nuts as required with proper alignment so as to be leak proof including necessary labour and required tools and plants.

d) Gate Valve

Scope:

Supplying and Installing gun metal gate valve of specified diameter having threaded ends, confirming to IS:778 mark, along with GI threaded nipple

Material:

Body: a) Brass b) Leaded tin Bronze

Bonnet or cover: a) Leaded tin bronze, b) Forged brass, c) Brass Stuffing box, disc hinge, check nut, stem nut, disc retaining nut, gland, gland *nut, gland flange, body seat rings and disc or wedge facing rings (where renewable):* a) Leaded tin bronze, b) Extruded brass rod, c) Forged brass, d) Brass

Stem, hinge pin and plug: a) Extruded brass rod, b) High-tensile brass, c) Forged Brass *Ball (for ball type check valves):* Chromium steel *Nut bolts:* Mild steel

TECHNICAL SPECIFICATIONS M&E

Hand wheel: Cast iron

Gasket: Compressed asbestos fibre

Gland packing: a) Hemp and jute, b) Asbestos

Spring: Phosphor bronze wire

Seating ring: Synthetic rubber

Method of Installation:

The Gate valve shall be fitted to pipe with provided flange, gaskets and Nut Bolts etc. Accessories with washers, spring washers and check nuts as required with proper alignment so as to be leak proof including necessary labor and required tools and plants.



Gate Valve

e) Butterfly valves

Scope:

Supplying & installing cast iron double flange butterfly valve of size 75/80mm.dia confirming to IS: 13095 having cast iron body, FG 220 Nitrile rubber replaceable seat with Moulded 'O' ring, C,1. powder coated disc flow control complete & tested to 1.5 times of working pressure in an approved manner.

Material:

Body: Cast iron Spheroid graphite iron Carbon steel

Disc: a) Cast iron Spheroid graphite iron carbon steel, b) Stainless steel Gun metal

c) Aluminum bronze . .

Shaft: a) Stainless steel, b) Carbon steel Aluminum bronze Nickel copper alloy

Seating ring/Seal retaining ring: a) Stainless steel, b) Gun metal aluminum bronze deposited metal suitable for duty or resilient material

Seat: Elastomers .

Shaft bearing seals: Manufacturer's standards suitable for duty

Internal fastenings: Stainless steel

External bolting: Carbon steel: tensile strength 390 n/mm or MPa

TECHNICAL SPECIFICATIONS M&E

Method of Installation:

The double flange butterfly valve shall be fitted with flange, gaskets, Nut bolts etc. to be fitted to pipe, accessories with washers, spring washers, check nuts as required with proper alignment so as to be leak proof including necessary labour and required tools and plants.



Butterfly valves

f) Non Return Valves

Scope:

Supplying and installing double flange NRV of specified diameter conforming to IS: 5312 (Part-I), ISI mark, having cast iron body, and gun metal working parts with nut bolts, gaskets, etc. and tested to 1.5 times of working pressure in an approved manner.

Material:

Body, cover, door, bearing holder: Grey cast iron

Hinge pin, door pin and door suspension pin: Stainless steel

Body seat rings: Leaded tin bronze

Door face ring: Leaded tin bronze

Bearing bushes! Bearing block: Leaded tin bronze

Plugs for hinged pin! Air release plug: Leaded tin bronze

Bolts: Carbon steel

Nuts: Carbon steel

Gaskets: Rubber

Hinges: Grey cast iron

Method of Installation:

TECHNICAL SPECIFICATIONS M&E

The double flange NRV shall be fitted to pipe with flange, gaskets, and Nut bolts etc, accessories with washers, spring washers, and check nuts as required with proper alignment so as to be leak proof including necessary labour and required tools and plants.



Non Return Valves

D) Hydrant Valve, Hoses, Hose Cabinet and Hose Reel

(Note: Items shall be BIS marked)

a. Branch pipe with nozzle

Branch pipe shall confirm to IS 903. Material of Installation shall confirm to IS 318 Gr LTB 2. Branch pipe shall have 63mm dia instantaneous type inlet at one end and second end shall have threading. The nozzle shall be of gunmetal, 20mm internal dia. The screwed inlet fitted to the branch pipe.



Branch pipe with nozzle

b. Hydrant Valves

Scope:

Hydrant shall be as per IS 5290 (Type "A") Hydrant valve shall have single/double outlet having 80 NB flanged inlet. Outlet shall be oblique female instantaneous type coupling having spring loaded lugs; internal parts shall be of copper or gunmetal. A cap with chain shall be provided on the outlet of the valve.

TECHNICAL SPECIFICATIONS M&E

Material:

Body: a) Brass, b) Leaded tin bronze

Bonnet or cover: a) Leaded tin bronze, b) Forged brass, c) Brass

Stuffing box, disc hinge, check nut, stem nut, disc retaining nut, gland, gland *nut*, *gland flange*, *body seat rings and disc or wedge facing rings (where renewable):* a) Leaded tin bronze, b) Extruded brass rod, c) Forged brass,

Stem, hinge pin and plug: a) Extruded brass rod, b) High-tensile brass, c) Forged Brass
Ball (for ball type check valves): Chromium steel

Nut bolts: Mild steel

Hand wheel: Cast Iron

Gasket: Compressed asbestos fibre

Gland packing: a) Hemp and jute, b) Asbestop

Spring: Phosphor bronze wire

Seating ring: Synthetic rubber

Method of Installation:

The Valve shall be fitted to pipe with provided flange, gaskets, and Nut bolts etc, accessories with washers, spring washers, and check nuts as required with proper alignment so as to be leak proof including necessary labour and required tools and plants.



Hydrant Valves

c. Priming Tank

Scope:

Supplying & Installing One piece Moulded HDPE 1 Fibre water tank of required capacity with necessary plumbing material on M.S. structural supports in an approved manner.

Material:

TECHNICAL SPECIFICATIONS M&E

Priming Tank: HDPE/ Fiber of good quality material

Gate Valves: As stated below

Method of Installation:

The Priming tank shall be installed on M.S. structural supports with 20/25 mm dia. inlet valve and 50 mm dia. outlet valve with necessary G.I. piping up to delivery of main fire pump before non-return valve.

d) Hose Reel

Scope:

Supplying and installing wall mounting swinging Hose reel drum as per IS: 884 and fitted with 19 mm dia 30 meter long high pressure polypropylene (Polyhose) pipe as per IS: 444 (type III) G.M. chrome plated nozzle and 19 mm dia and G.M. gate/ ball valve on the inlet pipe with necessary M.S. Bracket for holding Hose reel drum fitted in position with wall fasteners/ pipe fasteners etc, in an approved manner.

Material:

Hub and sides: Aluminium Alloy/Mild steel/ Aluminium sheet

Wall Bracket: Cast iron / Mild steel.

Hose tube (19 mm): Thermoplastic (Textile Reinforced) Type-2, (Nominal internal dia) as per IS- 12585

Nozzle with branch Pipe: Brass as per IS 8090

Stop Valve (Ball Valve): Gun metal.

Method of Installation:

The Wall Mounting swinging Hose reel drum with Gun Metal Nozzle, gate valve, shall be fixed on M.S. bracket with gaskets, Nut bolts etc. with use of required tools and plants. The water flow rate shall be not less than 24 LPM and the range of jet shall be not less than 6 metre.



Hose reel

TECHNICAL SPECIFICATIONS M&E

e. Hose pipe for Hose reel

Scope:

Supplying & erecting high pressure polypropylene/ thermoplastic hose pipe 19 mm. dia as per IS 444- type III & IS 446-1980 type I fabricated from polyester / Thermoplastic core braided with high tensile textile yarn suitable for erection of 19 mm Gun Metal Chrome plated nozzle.

Material:

Hose pipe material: Polypropylene/ Thermoplastic the lining and the cover shall be of uniform thickness, reasonably concentric and free from air blisters, porosity and splits. The tensile strength shall be minimum 5.00 MPa and shall withstand for 10.2 kg/cm^2

Nozzle: Chrome plated gun metal

Method of Installation:

The hose pipe shall be connected with couplings Nozzles etc.



Hose pipe

f. Rubber Hose Pipe

Scope:

Supplying & erecting high pressure rubber hose pipe 20 mm. Dia as per IS 446- 1978 (type I) & IS 444- 1978 (type 11) fabricated lead moulded with high tensile yarn braided rubber hose pipe suitable for erection of 19 mm gun metal Chrome plated nozzle.

Material:

Hose pipe material: Rubber. The lining and the cover shall be of uniform thickness, reasonably concentric and free from air blisters, porosity, and splits. The tensile shall be minimum 5.0.0 MPa and shall withstand pressure of 10.2 kg/cm^2

TECHNICAL SPECIFICATIONS M&E

Nozzle: Chrome plated gun metal

Method of Installation:

The hose pipe shall be connected with provided couplings.



Rubber hose pipe

g. Controlled Percolation Hose Pipe

Scope:

Supplying fire fighting C P (Controlled Percolation) Hose pipe of 63 mm in diameter, conforming to IS: 8423, and 2 nos. of 15 metre in length, fitted with male and female G. M. coupling conforming to IS: 903, ISI mark.

Material:

Hose pipe material: Synthetic cotton yarn conforming to IS 8423 and shall be made of jacket or cotton or synthetic material or their combination. It shall be tested as specified in IS and shall withstand for pressure 10.2 kgf/cm^2 and should not burst before a pressure of 35.7 kg/cm^2 is reached.

Coupling: Gun metal conforming to IS 903

Method of Installation:

Hose pipe of 15 metre length with male and female Gun metal coupling shall be connected as per direction.

TECHNICAL SPECIFICATIONS M&E

h. Canvas Rubber Hose Pipe

Scope:

Supplying fire fighting canvas / Rubber Hose pipe, conforming to IS: 4927 and 2 nos. X 15 metre length, fitted with male and female G.M. coupling conforming to IS: 903, with ISI mark storing them in metal cabinets

Material:

Hose pipe material: Canvas

Coupling: Gun metal

Method of Installation:

Canvas hose pipe 15 metre in length with male and female Gun metal coupling including necessary labour, material and use of required tool and plants.

i) Nozzles

Scope:

Supplying G.M./SS branch pipe of 63 mm diameter with specified length fitted with 20 mm diameter detachable hexagonal nozzle confirming to Is: 903, ISI mark.

Material:

Nozzle: Chrome plated Gun metal/SS

Method of Installation:

Gun metal /SS hexagonal nozzle fitted with branch pipe of 63mm dia. including necessary labour, material, etc.



Canvas Hose pipe

TECHNICAL SPECIFICATIONS M&E

E) Fire Brigade connection

Scope:

Supplying and installing fire brigade Header connection of 150 mm dia, G.I. 'C' class pipe having 2 Nos. of 100 mm 'T' outlet with 100 mm dia. flange, fitted with 2 Nos. of G.M. fire branching inlet connection, each consisting of 2 Nos. 63 mm dia. G.M. male inlet for supplying water in fire tank.

Material:

Pipe material: G.I. 'C' class (Heavy duty)

Branching Inlet: Gun metal

Male Inlet: Gun metal

Method of Installation:

In case under ground storage tank is not approachable by fire tenders, a 4 way 63 mm diameter instantaneous male inlet connection is provided at street level and connected to UG tank with 1 meter length of 150mm. diameter under ground pipe.

The whole unit shall be placed in MS box made of 2 mm thick MS sheet with openable glass cover.



Fire Brigade connection

F) Siamese connection (Fire service Inlet)

Scope:

Supplying and installing fire brigade Header (Siamese Connection) of 150 mm dia., G.I. 'C' class pipe having 4 Nos. of 63 mm 'T' outlet with 63 mm dia flange, fitted with 4 Nos. of .M. male inlets with spring type NRV for supplying water to Wet riser.

Material:

Pipe material: G.I. 'C' class

Branching Inlet: Gun metal

Male Inlet: Gun metal

Non Return Valve: As per above.

Method of Installation:

TECHNICAL SPECIFICATIONS M&E

In order to facilitate feeding of water in the system by fire service, a 4 way 63 mm diameter collecting head shall be provided and connected with each riser/down comer and the ring main with non return valve and butterfly/slucie valve. This should be located at a place where fire brigade tender can reach.

The whole unit is placed in MS box made of 2 mm thick MS sheet with open-able glass cover.



Siamese connection (Fire service Inlet)

G) Air Cushion Tank (Air Vessel)

Scope:

Supplying and installing Air Vessel of 300 mm dia. 1.5 mtr. in height M.S. Tank fabricated from M.S. black ERW pipe, conforming to I.S.: 3589, having 6mm thickness, flange at both ends, duly welded with 300 mm dia. pipe, having inlet of 100 mm dia., duly fitted with 100 mm dia. sluice valve and 20/25 mm dia. G.M. gate valve as drain valve , to be installed inside pump house along with M.S. angle tripod.

Material:

Air Vessel: MS ERW pipe confirming to IS 3589

Tripod: MS angle of size 75 x 75.x 5mm

Method of Installation:

300mm dia, 1.5 metre height air vessel, Gate Valve, flanges, MS angle Tripod including necessary labour, material and use of required tools and plants.

TECHNICAL SPECIFICATIONS M&E



Air Cushion Tank (Air Vessel)

H) MS/ CRCA Boxes Scope:

Scope

- a) Supplying and erecting M.S./CRCA cabinet for housing single hydrant valve (size 400 x 400 x 400mm.) made from 16 SWG sheet and angle iron 25 mm. x 25 mm. x 4 mm. having front doors with viewing glass (8"x6") and locking arrangement with necessary fixing material such as rubber bidding etc. duly painted in post box red colour
- b) Supplying and erecting M.S./CRCA cabinet for housing Fire Brigade / SIEMESE connections (size 1250 x 400 x 300 mm.) made from 16 SWG sheet and angle iron 25 mm. X 25 mm. x 4 mm. having front doors with viewing glass (8" x 6") and locking arrangement with necessary fixing material such as rubber bidding etc. duly painted in post box red colour.

Material:

MS/CRCA cabinets shall be fabricated from 16 SWG CRCA sheet with locking arrangement. Each hose cabinet shall accommodate two nos. of 15 Mt. Long hose-pipes and one no. of branch pipe with nozzle. The fire hose cabinet will have the legend "FIRE HOSE" painted prominently in the graphic style.



MS/ CRCA BoxesScope

I) Air Release Valve

Scope:

Supplying and erecting Air release cock of 20/25 mm dia. made from G.M. with necessary G.I coupling for fixing on top of Air vessel or on wet riser.

Material:

Air release Valve: Gun metal

Coupling: GI.

Method of Installation:

Air release Valve with necessary GI Coupling shall be fixed on top of wet riser / Air vessel with required labour, tools, etc



Air Release Valve

J) Pressure Gauge

Scope:

Supplying and installing pressure gauge of 100 mm dia. 0-300 PSI or 0-21 kg/cm² fitted with 12/15 mm dia. pad cock valve, and GI pipe, elbow etc. as per requirement in an approved manner.

Material:

Pressure Gauge: 100 mm diameter made from Brass metal.

Cock valve, elbow, and pipe: G.I

Method of Installation:

The 100 mm dia pressure gauge with G I cock valve, erected with GI Pipe including accessories, with required labour, tools, etc, as directed by the Engineer-in-charge.



Pressure Gauge

K) Pressure Switch

Scope:

Supplying and installing pressure switch with 12/15 mm dia. isolation valve, G.I nipple, elbow etc. in an approved manner.

Material:

Pressure switch: Brass metal / SS

Isolation valve, elbow, Nipple: G.I

Method of Installation:

The Pressure switch with G I isolation valve, and necessary GI fittings (elbow, Nipple) fitted with required labour, tools, etc.



Pressure Switch

L) Orifice plate

Scope:

Supplying and erecting one no. Brass orifice plate having 6 mm. thick with specified outer diameter and suitable inner diameter to reduce the pressure between 3.5 kg/cm² to 5.5 kg/cm²

Material:

Body: Brass 6 mm thick

Method of Installation:

The Orifice plate shall be placed before the hydrant valve.



M) Automatic Sprinkler

SCOPE:

Supplying and erecting 15 mm (1/2") dia. NBCM Body chrome finished quartzoid bulb sprinkler having 68° C fixed temperature rating with deflector disc of conventional Installation and quality conforming to international standards and listed by LPC (formally FOC U.K.) U.L.F.M. of USA or approved and listed by Tariff Advisory Committee (TAC) OF India

Sprinkler shall be chrome finished sufficiently strong, in compression to withstand any pressure, surge or hammer likely to occur in the system. The yoke & body shall be made of high quality chrome finished with arms streamlined to ensure minimum interference with the spread of water. The deflector of suitable design shall be fitted to give even distribution of water over the area commanded by the sprinkler. The bulb shall contain a liquid having a freezing point below any natural climatic figure and a high coefficient of expansion. The temperature rating of the sprinkler shall be stamped on the deflector & the colour of the liquid filled in the bulb shall be according to the temperature rating as per NFPA standard.

The sprinkler heads shall be of type & quality approved by the local fire brigade authority. The inlet shall be screwed.

The sprinklers shall have 15mm nominal size of the orifice for ordinary hazard. The orifice size shall be marked on the body or the deflector of the sprinkler.

Metal guards for protection of sprinkler against accidental or mechanical damage shall be provided as desired by the **site Engineer**

Operating Temperature

The Operating temperature at which the quartzoid bulb of the sprinkler head shall actuate, shall be 68 degree C or as specifically mentioned.

TECHNICAL SPECIFICATIONS M&E

Sprinkler Installation

Sprinkler heads shall be located in positions shown on the drawings. While slight relocation may result from building Installation features or interference from other services, the maximum spacing between sprinkler heads and coverage area shall not exceed those stipulated in the IS:15105 regulations and the NFPA 13-1994 Rules.

Allowance shall be made for such relocations within a radius of 1500 mm of the indicated positions without additional cost. The Fire Protection Services shall co-ordinate with the civil work to set out the sprinkler locations to suit the site location of the unit grid. In general, all sprinklers shall be located at the center of the ceiling unit. Chrome plated wire mesh guards shall be used to protect the sprinkler heads which are liable to accidental or mechanical damage as desired by site engineer.

Flow Requirements

The flow requirement for sprinkler heads shall be specifically approved for the designated area of installation.

SCOPE:

Supplying & erecting vane type water flow detector suitable for detecting flow of water in wet sprinkler pipe of main line or branch lines

Water flow detector (flow switch) shall have a paddle made of flexible and sturdy material of the width to fit within the pipe bore. The terminal box shall be mounted over the paddle/ pipe through a connecting socket. The Switch shall be potential free in either N O or N C position as required. The switch shall be able to trip and make / break contact on the operation of a single sprinkler head. The terminal box shall have connections for wiring to the Annunciation Panel. The flow switch shall have IP: 55 protection. The flow switch work at a triggering threshold bandwidth (flow rate) of 4 to 10 GPM. Further, it shall have a 'Retard' to compensate for line leakage or intermitted flows.

Material:

Visual Switch Activation 2) Rugged Switch Assembly 3) Heavy Duty Aluminum pipe Saddles 4) Durable Metal Encloser 5) Steel U Bolts For Secure Mounting 6) Two SPDT (Single Pole Double Track) Synchronized Switches 7) Serviceable Without Draining Pipes



Automatic Sprinkler

N) Fire Safety Audit

Fire safety audit shall be carried as per Maharashtra Fire Safety Act 2006 and Maha III of 2007. fire safety audit report shall consists of details and working status of all the fire accessories and equipment's installed in the building and premises.

O) Auto Glow Signage's:

The Fire Safety signage's shall be as per Indian standard IS 12349. The signs shall be square and colour and size mentioned shall be as per standard. The signage's shall be superior quality and visible in night .

P) HAND HELD FIRE EXTINGUISHERS

SCOPE:

Supplying and erecting fire extinguisher as per IS : 13849/15683 of capacity as mentioned in work order/tender with necessary clamp for erection on wall.

Work under this section shall consist of furnishing all labour, materials, appliances and equipment necessary and required to install fire extinguishing hand appliances as per relevant specification at locations indicated by site engineer.

a. ABC Type/ Dry Chemical Powder Extinguisher

The Extinguisher shall be filled with ABC grade 40, Mono Ammonium Phosphate 40% from any approved manufacturer.

The capacity of the extinguisher when filled with Dry Chemical Powder (First filling) as per IS 15683-2006, shall be 6 Kg +/-2% or 9 Kg +/- 3%.

The distribution of fire extinguishers to be as per IS 2190 – 1992.

TECHNICAL SPECIFICATIONS M&E

It shall be operated upright, with a squeeze grip valve to control discharge. The plunger neck shall have a safety clip, fitted with a pin, to prevent accidental discharge. It shall be pressurised with Dry Nitrogen, as expellant. The Nitrogen to be charged at a pressure of 15 Kg/cm² Body shall be of mild steel conforming to relevant IS Standards. The neck ring shall be also mild steel and welded to the body. The discharge valve body, shall be forged brass or leaded bronze, while the spindle, spring and siphon tube shall be of brass. The nozzle shall be of brass, while the hose shall be braided nylon. The body shall be cylindrical in shape, with the dish and dome welded to it. Sufficient space for Nitrogen gas shall be provided inside the body, above the powder filling.

The Neck Ring shall be externally threaded - the threading portion being 1.6 cm. The filler opening in the neck ring shall not less than 50 mm. Discharge nozzle shall be screwed to the hose. The design of the nozzle shall meet the performance requirement, so as to discharge at least 85% of contents upto a throw of 4 mtrs, continuously, at least for 15 seconds. The hose, forming part of discharge nozzle, shall be 500 mm long, with 10 mm dia internally for 6 Kg capacity and 12 mm for 9 Kg capacity. The extinguisher shall be treated with anti-corrosive paint, and it shall be labelled with words ABC 2.5 cm long, within a triangle of 5 cm on each face. The extinguisher body and valve assembly shall withstand internal pressure of 30 Kg/cm² for a minimum period of 2 minutes.

b. Carbon Dioxide Extinguisher

The Carbon Dioxide Extinguisher shall be as per IS: 15683:2006

The body shall be constructed of seamless tube conforming to IS:7285 and having a convex dome and flat base. Its dia shall be maximum 140 mm, and the overall height shall not exceed 720 mm.

The discharge mechanism shall be through a control valve conforming to IS:3224. The internal siphon tube shall be of copper aluminium conforming to relevant specifications. Hose Pipe shall be high pressure braided Rubber hose with a minimum burst pressure of 140 Kg/cm² and shall be approximately 1.0 meter in length having internal dia of 10 mm. The discharge horn shall be of high quality unbreakable plastic with gradually expanding shape, to convert liquid carbon dioxide into gas form. The hand grip of Discharge horn shall be insulated with Rubber of appropriate thickness. The gas shall be conforming to IS:307 and shall be stored at about 85 Kg/cm². The expansion ratio between stored liquid carbon dioxide to expanded gas shall be 1:9 times and the total discharge time (effective) shall be

TECHNICAL SPECIFICATIONS M&E

minimum 10 secs and maximum 25 secs. The extinguisher shall fulfill the following test pressures:

Cylinder: 236 Kg/cm²

Control Valve: 125 Kg/cm²

Burst Pressure of Hose: 140 Kg/cm² minimum

It shall be an Upright type. The cylinder, including the control valve and high pressure Discharge Hose must comply with relevant Statutory Regulations, and be approved by Chief Controller of Explosives, Nagpur and also bear IS marking. The Extinguisher including components shall be IS marked.



HAND HELD FIRE EXTINGUISHERS

Q) Fire Bucket , stand and Hook

Providing Round bottom FIRE Bucket of 9 Litres capacity as per IS : 2546 made out of 24 gauge G.I. sheet with extra handle . Inside and bottom shall be duly painted white and Outside of the Fire Bucket shall be painted with primer and Fire Red Colour. the word FIRE shall be written outside the bucket in bold black letters

Providing Floor mounting stand for keeping 4 Nos. of FIRE buckets 1500mm in length, 900mm in height frame made out of 30x30x4 mm angle iron with cross supports for legs, welded with 4 hooks and duly painted with one coat of red lead and two coats of silver Paint.

Supplying and erecting Wall hook 225mm projection for keeping fire buckets made out of 15 mm dia. M.S. Rod grouted in wall to a depth of minimum 15cms



Fire Bucket , stand and Hook

R) First Aid Kit:

Supplying and installing first aid kit in line with Indian standard IS 13115. Supplying standard first aid box with necessary antiseptic cream, medicine for use on wounds due burn, crepe bandage, gauze bandage, medicated ready to use bandage (Bandaid) adhesive tape for medicinal use, scissors, anti-septic solution etc. (All above contents shall be of standard makes)



TECHNICAL SPECIFICATIONS M&E

FIRE ALARM SYSTEM – SP-ME-TS- 65

1. Addressable Main Fire Alarm Control Panel (FACP)

Sr. No	Parameter	:	Requirement
A.	GENERAL		
1.	Type	:	Microprocessor Based
2.	Panel Location	:	At control room OR As per requirement
B.	DISPLAY ON PANEL		
3.	Type	:	Backlit LCD
4.	Lines X Characters	:	LCD, Alphanumeric, display of addresses, 640 characters
5	Parameters to be displayed		
	A. Addresses	:	Required
	B. Fire situation	:	Required
	C. Fire progression	:	Required
	D. Evacuation details	:	Required
6	LED indication for		
	A. Power ON	:	Required
	B. Fire alarm	:	Required
	C. Maintenance	:	Required
	D. Fault conditions	:	Required
7	Programming facility	:	Keypad / Touch screen
8	Password and selectable access level	:	Required
9	Switches / Push buttons	:	Acknowledge, Silence and System reset
C.	PANEL CHARACTERISTICS		
10.	Audio indication on alarm	:	Required
11.	Fault isolation capability	:	Required
12.	Alarm verification capability	:	Required
13.	Sensitivity adjustment	:	Required
14.	Sensor self test capability	:	Required
15.	Zone wise grouping	:	Required
16.	Response time	:	10 Seconds (Max) for full loaded panel. (Note - 1)
17.	Fault tolerant wiring capability	:	Required

TECHNICAL SPECIFICATIONS M&E

18.	No. of loops per Panel	:	2/ 4 Nos. Loops (Working(to be provided) + Spares for future)
19.	Expansion capability	:	Required
20.	Minimum addressable points per loop	:	Each loop shall be loaded upto 80% of its capacity. however 20% spare shall be considered in each loop for future additional detectors / devices.
21.	SLC loop cabling type	:	Style 6, class 'A' as per NFPA 72
22.	Loop length supported	:	Upto 1.5 Km
23.	Memory	:	NON-Volatile, NON-Erasable and NON-Rewritable
24.	Networking		
	A. Panel to Panel	:	Required
	B. Panel to Repeater Panel	:	Required
	C. Panel to Graphical User Interface (GUI)	:	Required
	D. Panel to printer	:	Required
25.	Networking protocol	:	RS-485
26.	Degraded mode operation	:	Required
27.	Redundancy for controller	:	Required
28.	Event recorder	:	Required
D.	POWER		
29.	Supply voltage to panel:	:	230V - 10%, 50Hz, UPS mains supply.
30.	Types of batteries	:	Sealed Maintenance Free (SMF) (Note 2)
31.	Battery capacity	:	As per NFPA 72 (Refer Note - 3 & 4)

32.	Terminal blocks for mains supply	:	Required
33.	Isolated earth bar for shield grounding	:	Required

TECHNICAL SPECIFICATIONS M&E

E.	MECHANICAL CHARACTERISTICS		
34.	Mounting:	:	Wall/ Surface/ Flush/ Semi Flush
35.	Sheet thickness:	:	1.6mm
36.	Housing material:	:	CRCA
F.	ENVN. CHARCTERISTICS		
37.	Ambient temperature range:	:	0-50°C
38.	Humidity range:	:	95%
39.	Weather protection class:	:	Min. IP20 for indoor panels located in air condition space.
G.	APPROVAL / CERTIFICATE		
40.	UL/ FM/ VDS/ EN-54/ LPCB :	:	Required
NOTES:			
1	The maximum allowable response delay from activation of an initiating device to receipt and display by the receiver/ fire alarm control unit shall be 10 seconds		
2	Battery shall be supplied having manufacturing date nearer to the supply date of battery.		
3	Battery shall have sufficient capacity to power the fire alarm system under non alarm condition for a minimum of 24 hours and shall be capable of operating the system during emergency condition for a period of 15 minutes at maximum connected load, upon normal AC power failure. The full load shall consist of simultaneous operation of all sounders, operation of detectors at least 25% of zones (with minimum of two zones) and the operation of fault indicators.		
4	Batteries shall have provision of automatic charging and automatic load switch-over whenever normal supply fails.		



Addressable Main Fire Alarm Control Panel (FACP)

TECHNICAL SPECIFICATIONS M&E

2. Active Repeater panel

Sr. No	Parameter	:	Requirement
A.	GENERAL		
1	Type	:	Microprocessor Based
2	Panel Location	:	At guard room as per requirement.
B.	DISPLAY ON PANEL		
3	Type	:	Backlit LCD
4	Lines X Characters	:	Alpha-numeric, LCD display with minimum 80 character, with LED indications
5	Parameters to be displayed		
	A. Addresses	:	Required
	B. Fire situation	:	Required
	C. Fire progression	:	Required
	D. Evacuation details	:	Required
6	LED indication for		
	A. Power ON	:	Required
	B. Fire alarm	:	Required
	C. Maintenance	:	Required
	D. Fault conditions	:	Required
7	Programming facility	:	Keypad / Touch screen
8	Password and selectable access level	:	Required
9	Switches / Push buttons	:	Acknowledge, Silence and System reset
C.	PANEL CHARACTERISTICS		
10	Audio indication on alarm	:	Required
11	Alarm verification capability	:	Required
12	Response time	:	10 Seconds (Max) for full loaded panel. (Note - 1)
13	Memory	:	NON-Volatile, NON-Erasable and NON-Rewritable
14	Networking	:	Required
15	Networking protocol	:	RS-485
D.	POWER		

TECHNICAL SPECIFICATIONS M&E

16	Supply voltage to panel	:	230V - 10%, 50Hz, UPS mains supply.
17	Types of batteries	:	Sealed Maintenance Free (SMF) (Refer Note - 2)
18	Battery capacity	:	As per NFPA 72 (Refer Note - 3 & 4)
19	Terminal blocks for mains supply	:	Required
20	Isolated earth bar for shield grounding	:	Required
E.	MECHANICAL CHARACTERISTICS		
21	Mounting	:	Wall/ Surface/ Flush/ Semi Flush
22	Sheet thickness	:	1.6mm
23	Housing material	:	CRCA
F.	ENVN. CHARCTERISTICS		
24	Ambient temperature range	:	0-50°C
25	Humidity range	:	5-95% non-condensing
26	Weather protection class	:	Min. IP20 for indoor panels located in air condition space.
G	APPROVAL / CERTIFICATE		
27	UL/ FM/ VDS/ EN-54/ LPCB	:	Required
NOTES:			
1	The maximum allowable response delay from activation of an initiating device to receipt and display by the receiver/ fire alarm control unit shall be 10 seconds		
2	Battery shall be supplied having manufacturing date nearer to the supply date of battery.		
3	Battery shall have sufficient capacity to power the fire alarm system under non alarm condition for a minimum of 24 hours and shall be capable of operating the system during emergency condition for a period of 15 minutes at maximum connected load, upon normal AC power failure. The full load shall consist of simultaneous operation of all sounders, operation of detectors at least 25% of zones (with minimum of two zones) and the operation of fault indicators.		
4	Batteries shall have provision of automatic charging and automatic load switch-over whenever normal supply fails.		

TECHNICAL SPECIFICATIONS M&E

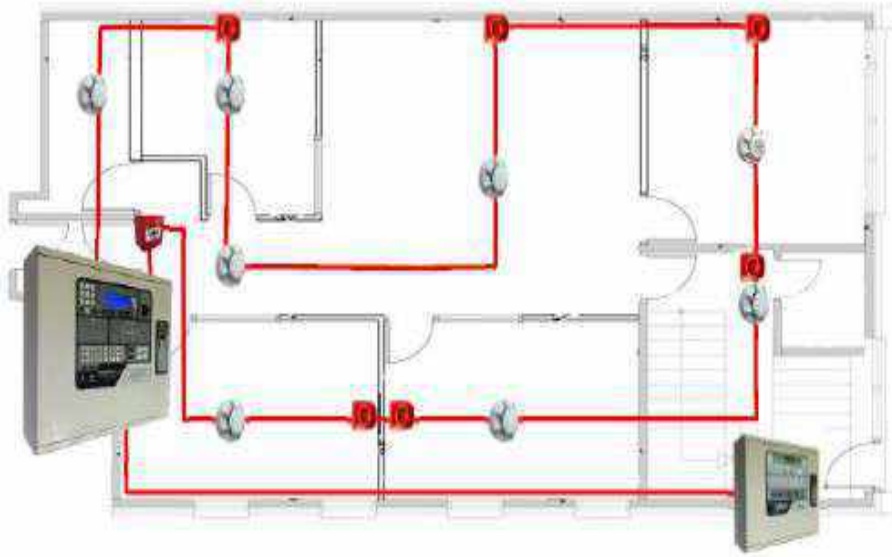

Active Repeater panel

3. Intelligent Photoelectric Smoke Detector

Sr. No	Parameter	:	Requirement
A.	DETECTOR CHARACTERISTICS		
1	Type	:	Microprocessor based photoelectric type
2	Addressable	:	Required
3	LED Status	:	Multi colored, multi status LED
4	Remote / Local Test Capability	:	Required
5	Response Time	:	10 seconds.
6	Terminals for connecting response indicator	:	Required (Refer Note1)
7	Sensitivity Adjustment	:	Required
8	Immune to false alarm	:	Required
9	Cabling	:	Two wire signal line circuit style 6, class 'A' as per NFPA-72
B.	POWER		
10	Operating voltage	:	15-32VDC (Loop powered)
C.	MECH. CHARACTERISTICS		
11	Material of Enclosure	:	Non Corrosive
D.	ENVI. PROPERTIES		

TECHNICAL SPECIFICATIONS M&E

12	Operating Temperature	:	0-50°C
13	Humidity Range	:	10-95% non-condensing
E.	APPROVAL/ CERTIFICATE		
14	UL/ FM/ VDS/ EN-54/ LPCB	:	Required
	NOTES:		
1	Bidder to consider fault isolator module after every 10 Nos. detectors/ devices for UL/ FM offered panel or inbuilt fault isolator base shall be provided for EN-54/ VDS/ LPCB offered panel. Bidder to provide necessary provision to connect the response indicator for any type of fire detectors.		



Intelligent PhotoElectric Smoke Detector

4. Intelligent Heat Detector

Sr .No	Parameter	:	Requirement
A.	DETECTOR CHARACTERISTICS		
1	Type	:	Microprocessor Based-Combination of Fixed Temperature and Rate of Rise of Temperature
2	Addressable	:	Required
3	LED Status:	:	Multi colored, multi status LED
4	Remote / Local Test Capability	:	Required
5	Response Time	:	10 seconds (Note:1)
6	Terminals for connecting response indicator	:	Required (Refer Note - 2)
7	For fixed temperature type	:	55°C
	For rate of rise of temp. type	:	7°C / Minutes
8	Sensitivity Adjustment	:	Required

TECHNICAL SPECIFICATIONS M&E

9	Immune to false alarm	:	Required
10	Cabling	:	Two wire signal line circuit style 6, class 'A' as per NFPA-72
11	Built-in isolator	:	Required (Note-3)
B. POWER			
12	Operating voltage	:	15-32VDC (Loop powered)
C. MECH. CHARACTERISTICS			
13	Material of Enclosure	:	Non Corrosive
D. ENVI. PROPERTIES			
14	Operating Temperature	:	0-50°C
15	Humidity Range	:	10-95% non-condensing
E. APPROVAL/ CERTIFICATE			
22	UL/ FM/ VDS/ EN-54/ LPCB	:	Required
NOTES:			
1	The maximum allowable response delay from activation of an initiating device to receipt and display by the receiver/ fire alarm control unit shall be 10 seconds		
2	Bidder to consider fault isolator module after every 10 Nos. detectors/ devices for UL/ FM offered panel or inbuilt fault isolator base shall be provided for EN-54/ VDS/ LPCB offered panel. Bidder to provide necessary provision to connect the response indicator for any type of fire detectors.		
3	In case of built-in isolator requirement the approval/ certification shall be VDS/ EN-54/ LPCB else UL/ FM approval/ certification shall be applicable.		



Intelligent Heat detector

TECHNICAL SPECIFICATIONS M&E

5. Intelligent multi-criteria Detector

Sr. No	Parameter	:	Requirement
A.	DETECTOR CHARACTERISTICS		
1	Type	:	Microprocessor based, combination of smoke and heat detector (Fixed and Rate of Rise of Temperature type)
2	Addressable	:	Required
3	LED Status	:	Multi colored, multi status LED
4	Remote / Local Test Capability	:	Required
5	Response Time	:	10 seconds (Note:1)
6	Terminals for connecting response indicator	:	Required (Note 2)
7	For fixed temperature type	:	55°C
	For rate of rise of temp. type	:	70° / Minutes
8	Sensitivity Adjustment	:	Required
9	Immune to false alarm	:	Required
10	Cabling	:	Two wire signal line circuit style 6, class 'A' as per NFPA-72
11	Built-in isolator	:	Required/ Not Required (Refer Note-2 &3)
B.	POWER		
12	Operating voltage	:	15-32VDC (Loop powered)
C.	MECH. CHARACTERISTICS		
13	Material of Enclosure	:	Non Corrosive
D.	ENVI. PROPERTIES		
14	Operating Temperature	:	0-50°C
15	Humidity Range	:	10-95% non-condensing
E.	APPROVAL/ CERTIFICATE		
16	UL/ FM/ VDS/ EN-54/ LPCB :	:	Required
	NOTES		
1	The maximum allowable response delay from activation of an initiating device to receipt and display by the receiver/ fire alarm control unit shall be 10 seconds		

TECHNICAL SPECIFICATIONS M&E

2	Bidder to consider fault isolator module after every 10 Nos. detectors/ devices for UL/ FM offered panel or inbuilt fault isolator base shall be provided for EN-54/ VDS/ LPCB offered panel. Bidder to provide necessary provision to connect the response indicator for any type of fire detectors.
3	In case of built-in isolator requirement the approval/ certification shall be VDS/ EN-54/ LPCB else UL/ FM approval/ certification shall be applicable.



Intelligent multi-criteria Detector

6. Addressable Manual Call Point/ Station

Sr. No	Parameter	:	Requirement
1	Type	:	Break glass type/ Push and pull type/ Lift and pull type
2	Clear and visible operating instructions on the body	:	Yes, Required
3	The word "FIRE" indication on the front of MCP in raised letters, 1.75 inches (44 mm) or larger	:	Yes, Required
4	Response Time	:	10 seconds
5	A. Two wire signal line circuit style 6, class 'A' as per NFPA-72 (For addressable) B. Two wire signal line circuit style 6, class 'B' as per NFPA-72 (For Conventional)	:	Yes, Required
6	Built-in isolator: Required/ Not Required	:	In case of built-in isolator requirement the approval/ certification shall be VDS/ EN-54/ LPCB else UL/ FM approval/ certification shall be applicable.
7	Operating Temperature	:	0-50°C

TECHNICAL SPECIFICATIONS M&E

8	Humidity Range	:	10-93% non-condensing
9	Weather protection class	:	IP54
	A. Indoor –	:	
10	UL/ FM/ VDS/ EN-54/ LPCB	:	Required



Addressable Manual Call Point/ Station

7. HOOTER cum STROBE

Sr. No	Parameter	:	Requirement
1	Type	:	Loop Powered / Externally Powered
2	Addressable	:	Addressable/ Conventional
3	Response time	:	10 seconds
4	dB level	:	A minimum sound level of either 65 dB(A) or 5 dB(A) above any other noise likely to persist for a period longer than 30 s
5	Strobe flashing rate at 1Hz	:	One flash per second
6	Number of selectable tones	:	Minimum 4
7	Cabling	:	Two wire signal line circuit style 6, class 'A' as per NFPA-72
8	Built-in isolator: Required/ Not Required	:	In case of built-in isolator requirement the approval/ certification shall be VDS/ EN-54/ LPCB else UL/ FM approval/ certification shall be applicable.

TECHNICAL SPECIFICATIONS M&E

9	Operating voltage	:	16 to 33 V (24 V nominal); 8 to 17.5 V (12 V nominal)
10	Material of Enclosure	:	Non Corrosive
11	Mounting	:	Wall/ surface / structure beam
12	Operating Temperature	:	0-50°C
13	Humidity Range	:	95%
14	Weather protection class	:	IP66
15	UL/ FM/ VDS/ EN-54/ LPCB	:	Yes Required



HOOTER cum STROBE

8. Reflective Type Beam Detector

Sr. No	Parameter	Requirement
A.	DETECTOR CHARACTERISTICS	
1	Type	Reflective beam type smoke detector
2	Addressable	Required/ Not Required (Note - 1)
3	LED Status	Multi colored, multi status LED
4	Remote / Local Test Capability:	Required
5	Response Time	10 seconds (Refer Note - 2)
6	Sensor Coverage	164 ft. & 325 ft.
7	Sensitivity Adjustment	Required
8	Immune to false alarm	Required

TECHNICAL SPECIFICATIONS M&E

9	Cabling	Two wire signal line circuit style 6, class 'A' as per NFPA-72
B. POWER		
10	Operating voltage :	15 to 32 VDC
C. MECH. CHARACTERISTICS		
11	Material of Enclosure :	Non Corrosive
12	Spacing & mounting:	As per the norms of NFPA 72,2010 edition & as per manufacturer's instructions
D. ENVI. PROPERTIES		
13	Operating Temperature :	0-50°C
14	Humidity Range :	10-93% non-condensing
15	Weather protection class:	For indoor application: IP 54
E. APPROVAL/ CERTIFICATE		
16	UL/ FM/ VDS/ EN-54/ LPCB :	Required
NOTES		
1	In case bidders offers conventional beam detector, same shall be made addressable by providing addressable monitor module.	
2	The maximum allowable response delay from activation of an initiating device to receipt and display by the receiver/ fire alarm control unit shall be 10 seconds	



Reflective Type Beam Detector

TECHNICAL SPECIFICATIONS M&E

9. Addressable Control Relay Module

Sr. No	Parameter	Requirement
A. MODULE CHARACTERISTICS		
Application:		
1	A. Activating conventional Hooter cum Strobe	Required
	B. To operate the dry contact for third party application	Required
2	Type	Microprocessor Based
3	Addressable	Required
4	Number of relay outputs in each module	1 No./ 2 Nos./ 4 Nos./ 8 Nos.
5	Type of relay contact / contact rating	Form-C relays 2.0A,1.0A @ 30 VDC max.
6	Cabling	Two wire signal line circuit style 6, class 'A' as per NFPA-72
7	Built-in isolator	Required/ Not Required (Refer Note-1)
B. POWER		
8	Operating voltage	15-30 VDC (Loop powered)
C. MECH. CHARACTERISTICS		
9	Material of Enclosure	Non Corrosive
D. ENVI. PROPERTIES		
10	Operating Temperature	0-50°C
11	Humidity Range	0 to 95%
Enclosure weather protection class		
12	A. For indoor IP54	Required
	B. For outdoor IP65	Required
E. APPROVAL/ CERTIFICATE		
13	UL/ FM/ VDS/ EN-54/ LPCB	Required
NOTES:		
1	In case of built-in isolator requirement the approval/ certification shall be VDS/ EN-54/ LPCB else UL/ FM approval/ certification shall be applicable.	

TECHNICAL SPECIFICATIONS M&E



Addressable Control Relay Module

10. 2 zone conventional fire alarm control panel

Sr. No.	Parameter	:	Requirement
A	MECHANICAL		
3	CONSTRUCTION	:	Fire retardant, ABS plastic moulded enclosure, sealed to IP30
4	CABLE ENTRY	:	18 x 20mm knockouts in top of enclosure 25 x 50 mm knockout in rear of enclosure
5	OPERATING TEMPERATURE	:	+5°C to +45°C
6	RELATIVE HUMIDITY	:	5% to 95% non condensing
B	ELECTRICAL		
1	OPERATING VOLTAGE	:	230 Vac 50/60 Hz (±15%)
2	INTERNAL POWER SUPPLY	:	Output voltage +18.5 to +28.5 Vdc Output Current 1.8 Amps maximum Maximum Alarm load: 1 Amp
3	STANDBY BATTERIES	:	Minimum capacity 2 x 12 V 2.8Ah Maximum capacity 2 x 12 V 7 Ah
4	STANDBY BATTERY TYPE	:	Sealed lead acid

TECHNICAL SPECIFICATIONS M&E

5	DETECTION CIRCUITS	:	2, 4 or 8 detection circuits 2 mA per circuit (typically >20 detectors)
6	DIGITAL INPUTS	:	Class Change, Alert, Evacuate, Reset
7	DIGITAL INPUT TRIGGER	:	Extended closing contact
8	EXTERNAL OUTPUTS	:	Sounder Outputs: 2 monitored outputs 0.5 Amps per circuit Auxiliary Output: +18.5 to +28.5 Vdc, 0.5 Amp. (max)



2 zone conventional fire alarm control panel

11. Remote response Indicator

Sr. No.	Parameter	:	Requirement
1	FEATURES	:	<ul style="list-style-type: none"> -Compatibility with all - Detectors - Dual LED Lamp - ABS Plastic - Indoor use Only - Wall Mounted - Ceiling Mount

TECHNICAL SPECIFICATIONS M&E

2	TECHNICAL	:	<ul style="list-style-type: none"> - Wire Entrance Back side of the Component - Alarm Current 10 mA, - LED Lamp 5 m.m - LED Lamp Glow Light colour red - Enclosure Colour White or Off White - Voltage 12VDC/24v Dc - Mounting Methods in of the Cabnet
---	-----------	---	--



Remote response Indicator

12. Isolation module with mounting box and termination glands.

Sr. No.	Parameter	:	Requirement
A.	MODULE CHARACTERISTICS		
1	Type	:	Microprocessor Based
2	Addressable	:	Required
3	After every numbers of detector/devices	:	10 nos.
4	Automatically resets on correction of short	:	Required
5	Wide viewing angle of LED	:	Required
6	Cabling	:	Two wire signal line circuit style 6, class A as per NFPA-72
B.	POWER		
7	Operating voltage	:	24 VDC (Loop powered)

TECHNICAL SPECIFICATIONS M&E

C.	MECH. CHARACTERISTICS		
8	Material of Enclosure	:	Non Corrosive
D.	ENVI. PROPERTIES		
9	Operating Temperature	:	0-50°C
10	Humidity Range	:	95%
11	Enclosure weather protection class:		
	A. For indoor	:	IP54
	B. For outdoor	:	IP65
E.	APPROVAL/ CERTIFICATE		
12	UL/ FM/ VDS:	:	Required



Isolation module with mounting box and termination glands

TECHNICAL SPECIFICATIONS M&E

13. Addressable Control Relay Module

Sr. No.	Parameter	Requirement
A.	MODULE CHARACTERISTICS	
1.	Application:	A. Activating conventional Hooter cum Strobe B. To operate the dry contact for third party application
2.	Type:	Microprocessor Based
3.	Addressable :	Required
4.	Number of relay outputs in each module:	1 No./ 2 Nos./ 4 Nos./ 8 Nos.
5.	Type of relay contact / contact rating:	Form-C relays/ 2 or 3 amp
6.	Cabling:	Two wire signal line circuit style 6, class 'A' as per NFPA-72
7.	Built-in isolator:	Required/ Not Required (Note-1)
B.	POWER	
8.	Operating voltage :	24 VDC (Loop powered)
C.	MECH. CHARACTERISTICS	
3.	Material of Enclosure :	Non Corrosive
D.	ENVI. PROPERTIES	
4.	Operating Temperature :	0-50°C
5.	Humidity Range :	95%
6.	Enclosure weather protection	A. For indoor IP54

TECHNICAL SPECIFICATIONS M&E

	class:	B. For outdoor IP65
E.	APPROVAL/ CERTIFICATE	
1.	UL/ FM/ VDS/ EN-54/ LPCB :	Required
F.	NOTES:	
1	In case of built-in isolator requirement the approval/ certification shall be VDS/ EN-54/ LPCB else UL/ FM approval/ certification shall be applicable.	

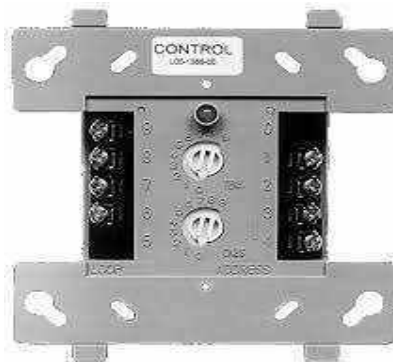

Adressable Control Relay Module

14. Passive repeater Panel

Description	:	Passive repeater panel
Standards	:	EN54/ UL/LPCB/VdS
Specification		
Mains input voltage	:	230V ac +10% / -15%
Operating voltage	:	18 to 32V
System indicators	:	Power on, fire, fault, test, disable and scroll

TECHNICAL SPECIFICATIONS M&E

Input ports	:	RS232 (for connection of programmer)
Battery	:	1 x 12V 3.2Ah
Standby duration	:	24 hours
Environmental		
Operating temperature	:	0°C to +25°C
Humidity (non condensing)	:	0 to 75% RH
Physical		
Construction	:	PC/ABS
Colour	:	Light Grey
Ingress protection	:	IP30
Compatibility	:	1.Suitable for use with brand of main intelligent addressable fire systems 2. Connects to RS485 peripheral bus



Passive Repeater Panel

15. 2 zone conventional fire alarm

Sr. No.	Parameter	:	Requirement
1	POWER SUPPLY:		
	(i) AC Supply	:	230 V AC, 50 Hz
	(ii) DC Supply	:	24 V DC

TECHNICAL SPECIFICATIONS M&E

2	Operating Conditions	:	+5°C to +35°C ,5% to 95 % RH
3	Operating Voltage	:	24 V DC
4	Construction	:	Fire retardant, ABS plastic moulded enclosure, sealed to IP30.
5	External outputs:		
	Sounder outputs	:	2 monitored outputs. 0.5 Amps per circuit.
	Auxiliary output	:	+18.5 to +28.5 Vdc, 0.5 Amp.
	Optional Relay card	:	1 x Fire relay (changeover contacts rating 30Vdc, 1 Amp). 1 x Fault relay (changeover contacts rating 30Vdc, 1 Amp).



2 zone conventional fire alarm

16. Conventional Heat Detector

Sr. No.	Parameter	:	Requirement
1	Operating Voltage	:	8-30VDC
2	Standby Current	:	≤1mA
3	Alarm Current	:	≤20mA
4	Indicator	:	Red. Quiet in polling, lights in alarming.

TECHNICAL SPECIFICATIONS M&E

5	Alarm Clear	:	Instantaneous Power-off (5s MAX, 2.5VDC MAX.)
6	Power-up Time	:	≤10s
7	Action Temperature	:	58°C
8	Output control type	:	Volt-free normally open, Keep closed after alarming
9	Output Capacitance	:	30VDC/1A
10	Ingress Protection Rating	:	IP23
11	Environmental Temperature	:	-10°C~+50°C
12	Relative Humidity	:	≤95%, non condensing
13	Material and Color of Enclosure	:	ABS, white (RAL 9016)



Conventional Heat Detector

17. conventional optical smoke detector

Sr. No.	Parameter	:	Requirement
1	Operating Voltage	:	8-30VDC
2	Standby Current	:	≤60μA
3	Alarm Current	:	10mA≤I≤30mA

TECHNICAL SPECIFICATIONS M&E

4	Indicator	:	Red. Quiet in polling, lights in alarming.
5	Alarm Clear	:	Instantaneous Power-off (5s MAX, 2.5VDC MAX.)
6	Power-up Time	:	≤10s
7	Wiring	:	Polarized 2-core for detection zone cable. Polarized 2-core for remote indicator
8	Ingress Protection Rating	:	IP30
9	Environmental Temperature	:	-10°C~+50°C
10	Relative Humidity	:	≤95%, non condensing
11	Material and Color of Enclosure	:	ABS, white (RAL 9016)



Conventional optical Smoke Detector

18. conventional manual call point

Sr. No.	Parameter	:	Requirement
1	Standard	:	EN54-part 11
2	Approval	:	LPCB, CE, UL, VdS
3	Protection rating	:	IP24D
4	Operating voltage	:	24-30VDC Loop

TECHNICAL SPECIFICATIONS M&E

5	Operating current	:	Standby current 0.8mA Alarm Current 2mA
6	Operating temperature	:	-10°C to +50°C
7	N/O Output contact	:	60Vdc, 0.1A
8	Contact resistance	:	100mΩ
9	Relative humidity	:	95%
10	Application	:	Indoor use
11	Visual Indicator	:	LED, Red (lit steady when alarm, 3 sec interval blinking at normal state)
12	Material and colour	:	ABS, red
13	Wiring	:	1 pair polarized



Conventinal Manual Call Point

19. conventional hooters

Sr. No.	Parameter	:	Requirement
1	System operating voltage	:	24 V DC
2	Sound pressure level	:	80dB at 16-33VDC
3	Tone nature	:	Dual Tone
4	Frequency range	:	(500Hz-1000Hz)
5	Operating temp	:	10°C to 42°C

TECHNICAL SPECIFICATIONS M&E

6	Cable entry	:	TOP / BACK 20MM KNOCKOUT
7	Cabinet	:	(ABS-FR) Body
8	Protection type	:	IP30



Conventional Hooters

TECHNICAL SPECIFICATIONS M&E

SP-ME-TS-66- SPECIFICATIONS FOR PIPE NATURAL GAS SYSTEM

Sr. No.	Fair Item No	Description of Item
1.	R2-ME-18-1-a	<u>SITC OF 3 INCH DIA MS SEAMLESS SCH40 PIPE</u> MS Seamless pipe ASTM Gr. A-106 Sch. 40 with seamless fittings like elbows, reducers and tees etc., construction rates to include fabrication & erection of support, Testing with compressed air at a 4 Kg / Cm ² , Nitrogen purging, Stencilling, two coats of epoxy paint of approved Colour Mahanagar gas Board etc. all complete.
2.	R2-ME-18-1-b	<u>SITC OF 2 INCH DIA MS SEAMLESS SCH40 PIPE</u> MS Seamless pipe ASTM Gr. A-106 Sch. 40 with seamless fittings like elbows, reducers and tees etc., construction rates to include fabrication & erection of support, Testing with compressed air at a 4 Kg / Cm ² , Nitrogen purging, Stencilling, two coats of epoxy paint of approved Colour Mahanagar gas Board etc. all complete.
3.	R2-ME-18-1-c	<u>SITC OF 1 INCH DIA MS SEAMLESS SCH40 PIPE</u> MS Seamless pipe ASTM Gr. A-106 Sch. 40 with seamless fittings like elbows, reducers and tees etc., construction rates to include fabrication & erection of support, Testing with compressed air at a 4 Kg / Cm ² , Nitrogen purging, Stencilling, two coats of epoxy paint of approved Colour Mahanagar gas Board etc. all complete.
		

TECHNICAL SPECIFICATIONS M&E

4.	R2-ME-18-1-d	<p><u>SITC of 3inch Dia. (flanged end) Manual cut-off Ball Valve, fire safe design, flanged to ASA150</u></p> <p>For operating of gas distribution system, use gun metal full bore ball valves as per specification duly confirmed by M/s Mahanagar Gas Ltd. Only approved make valves shall be used in pipeline network. Flanges shall be used at each valve location and it shall be approximately of 12mm thickness X 150mm width. Flanges shall be fixed with G.I Stud nut bolts & washer of suitable size. Ball valves are to be used for isolation of equipment's / components. The valves may have ISO 5211 mounting pad and double body sealing arrangement. The valves shall be of full bore design only. The seat will be of PTFE. The valve design shall be as per BS: 5351/ API: 6D</p>
5.	R2-ME-18-1-e	<p><u>SITC of 2inch Dia. (flanged end) Manual cut-off Ball Valve, fire safe design, flanged to ASA150</u></p> <p>For operating of gas distribution system, use gun metal full bore ball valves as per specification duly confirmed by M/s Mahanagar Gas Ltd. Only approved make valves shall be used in pipeline network. Flanges shall be used at each valve location and it shall be approximately of 12mm thickness X 150mm width. Flanges shall be fixed with G.I Stud nut bolts & washer of suitable size. Ball valves are to be used for isolation of equipment's / components. The valves may have ISO 5211 mounting pad and double body sealing arrangement. The valves shall be of full bore design only. The seat will be of PTFE. The valve design shall be as per BS: 5351/ API: 6D</p>

TECHNICAL SPECIFICATIONS M&E

6.	R2-ME-18-1-f	<p><u>SITC of 1inch Dia. (flanged end) Manual cut-off Ball Valve, fire safe design, flanged to ASA150</u></p> <p>For operating of gas distribution system, use gun metal full bore ball valves as per specification duly confirmed by M/s Mahanagar Gas Ltd. Only approved make valves shall be used in pipeline network. Flanges shall be used at each valve location and it shall be approximately of 12mm thickness X 150mm width. Flanges shall be fixed with G.I Stud nut bolts & washer of suitable size. Ball valves are to be used for isolation of equipment's / components. The valves may have ISO 5211 mounting pad and double body sealing arrangement. The valves shall be of full bore design only. The seat will be of PTFE. The valve design shall be as per BS: 5351/ API: 6D</p>
		 <p style="text-align: center;">Manual cut-off Ball Valve</p>
7.	R2-ME-18-1-g	<p><u>SITC & Putting in operation of M.S. Flanges 3 inch</u></p> <p>SITC & Putting in operation of MS flange 3 inch Dia.</p> <ul style="list-style-type: none"> a) Material: ASME B 16.5 b) Dimensions: ANSI B.16.5 c) Rating / Wall Thickness: 150 lbs d) Construction: Machined e) Joint Type: Slip-on f) Face: Raised Face

TECHNICAL SPECIFICATIONS M&E

8.	R2-ME-18-1-h	<p><u>SITC & Putting in operation of M.S. Flanges 2 inch</u></p> <p>SITC & Putting in operation of MS flange 2 inch Dia.</p> <ul style="list-style-type: none">a) Material: ASME B 16.5b) Dimensions: ANSI B.16.5c) Rating / Wall Thickness: 150 lbsd) Construction: Machinede) Joint Type: Slip-onf) Face: Raised Face
9.	R2-ME-18-1-i	<p><u>SITC & Putting in operation of M.S. Flanges 1 inch</u></p> <p>SITC & Putting in operation of MS flange 1 inch Dia.</p> <ul style="list-style-type: none">a) Material: ASME B 16.5b) Dimensions: ANSI B.16.5c) Rating / Wall Thickness: 150 lbsd) Construction: Machinede) Joint Type: Slip-onf) Face: Raised Face
		<div data-bbox="695 1184 1256 1787" data-label="Image">A photograph of a circular metal flange, likely made of mild steel (M.S.), showing a central hole and four smaller holes around the perimeter. The flange has a raised face and a slip-on joint type.</div> <p data-bbox="797 1808 959 1839" style="text-align: center;">M.S.Flanges</p>



TECHNICAL SPECIFICATIONS M&E

10.	R2-ME-18-1-j	<p><u>Designing and Co-ordination with MGL</u></p> <p>Proposed shall be designed & installed such that it shall meet the guaranteed performance requirements of M/s Mahanagar Gas Ltd (MGL)'s operation and maintenance department and any government non-government undertaking/agency. This includes compliance of fulfilling all the norms to start supply of gas from M/s Mahanagar Gas Ltd. (MGL) and respective government non-government undertaking/ agency. Installed system will be accepted and taken-over by MCGM for regular operation only after satisfactory performance testing in all respect & clearance from M/s Mahanagar Gas Ltd. (MGL) and their approval /clearance shall be in the scope of contract.</p>
11.	R2-ME-18-1-k	<p><u>SITC of Hydraulic flexible pipe of one meter length with size 25mm</u></p> <p>SITC of Hydraulic flexible pipe of 1mtr.Length with size25 mm NB (Nominal Bore) including required fittings etc.</p> <p>Construction:</p> <ol style="list-style-type: none">1. Inner Tube:Seamless inner tube of LPG synthetic rubber.2. Reinforcement:Textile braids below a layer of brass-coated high tensile steel wire.3. Outer Cover: Weather abrasion, atmospheric exposure resistant synthetic rubber cover.4. Temperature:-20°C to +45°C.5. Application: For high pressure.6. End Connectio: Swaged or Crimped or Reusable type.

TECHNICAL SPECIFICATIONS M&E

		 <hr/>
		Hydraulic Flexible pipe
12.	R2-ME-18-1-I	<p><u>SITC of Gas pressure Regulator of size 25mm</u></p> <p>SITC of Gas pressure Regulator of size 25mm (nominal Bore) for gas pressure from 100 mbar to 30 (make: United/Vanaz or equivalent)</p> <ul style="list-style-type: none">● Type :1st stage● Colour :Blue● Thread Size :Inlet F.E.C.V. and Outlet 3/8: BSPPF● Inlet pressure :0.35-2.1kg/cm²● Delivery pressure :0.035 kg/cm²● Flow rate :1.50 Kg/hr.

TECHNICAL SPECIFICATIONS M&E

		 <hr/> <p>Gas pressure Regulator</p>
13.	R2-ME-18-1-m	<p><u>SITC of Manual needle valve</u></p> <p>SITC of Manual Needle valve with Long Spindle can be used for high & low pressure operation and come with a forged brass.</p> <ul style="list-style-type: none">● Material: Brass● Size : 3/8" X 3/8" or depending upon the requirements
		 <hr/> <p>Needle valve</p>

TECHNICAL SPECIFICATIONS M&E

14.

SITC of Stainless Steel Gas Stove suitable for PNG gas

SS Gas Stove of

- a) Size: 1X1 (LXB)
- b) Frame work:SS 304 Square Bar of standard ASTM A276 Size 1 Inch Grade SWG 18
- c) Outer Body : SS 304 Stainless Steel role Sheet of Grade SWG 18 is fabricated, Covered and polished around the surrounding of frame
- d) Control type: Needle Valve of ½” Size
- e) Medium Natural Gas/ LPG
- f) Conversion: Needed as the Medium Changes
- g) Burner Types: G-09

R2-ME-18-1-n



Drum Burners

- h) Burner Pressure: 4 PSIG
- i) Consumption Rate:1.5KG/Hr
- j) Rated Heat:90000 Btu/hr
- k) Manifold: ½” SS 304 Seamless pipe is fixed and fabricated with two end is fixed with end plug
- l) Pigtail: Copper Pipe with both the ends are fixed with female type nuts
- m) Pin: Loose Pin is fabricated over Manifold and pigtail is connected to pin.

TECHNICAL SPECIFICATIONS M&E

15.	R2-ME-18-1-o	<p><u>SITC of Stainless Steel Gas pencil type Burner</u></p> <p>SITC of PNG SS Gas Pencil Burner suitable for PNG gas with one way/ two way arrangement as per site requirements</p> <p><u>Dimension</u></p> <ul style="list-style-type: none">(i) Length-150mm,(ii) Base diameter-80mm(iii) Optimum working pressure:0.035kg/cm2(iv) Consumption per hour: 0.1 kgs(v) Rated Heat Output :680 kcal/hr
16.	R2-ME-18-1-p	<p><u>SITC of T-50 PNG Gas Burner</u></p> <p>SITC of T-50 PNG Gas Burner</p> <ul style="list-style-type: none">• consumption per hour 2.24 Kgs• length 230mm, head dia 96mm• Rated heat output 25200kcal/hr. <p>These are heavy duty burners for use in general cooking, bulk frying and for general heating requirements. These burners are recommended to be used at a pressure of 0.3kg/cm2 (4.5 psig), however, this may be varied by $\pm 25\%$ the heat output being varied accordingly.</p> 

TECHNICAL SPECIFICATIONS M&E

17.

SITC of T-78 PNG Gas Burner

SITC of T-78 PNG Gas Burner

- **consumption per hour 3.56 Kgs**
- **length 245 mm, head dia 115mm**
- Rated heat output 40350kcal/hr.

These are heavy duty burners for use in general cooking, bulk frying and for general heating requirements. These burners are recommended to be used at a pressure of 0.3kg/cm² (4.5 psig), however, this may be varied by $\pm 25\%$ the heat output being varied accordingly.

R2-ME-18-1-q



TECHNICAL SPECIFICATIONS M&E

18.	R2-ME-18-1-r	<p><u>SITC of Domestic Burner</u></p> <p>SITC of Domestic PNG Gas Burner</p> <ul style="list-style-type: none">(i) consumption per hour 1.20 Kgs(ii) head dia 50mm(iii) Rated heat output 9500kcal/hr. <p>These are heavy duty burners for use in general cooking, bulk frying and for general heating requirements. These burners are recommended to be used at a pressure of 0.3 kg/cm² (4.5 psig), however, this may be varied by $\pm 25\%$ the heat output being varied accordingly.</p> 
-----	---------------------	--

TECHNICAL SPECIFICATIONS M&E

19.

SITC of Drum burner T-35 meet burner

SITC of Drum PNG Gas Burner

- (i) **consumption per hour 1.580 Kgs**
- (ii) **head dia 60mm**
- (iii) **Rated heat output 15500kcal/hr.**

These are heavy duty burners for use in general cooking, bulk frying and for general heating requirements. These burners are recommended to be used at a pressure of 0.3 kg/cm² (4.5 psig), however, this may be varied by $\pm 25\%$ the heat output being varied accordingly.

R2-ME-18-1-s



T-35 meet burner

TECHNICAL SPECIFICATIONS M&E

20.	R2-ME-18-1-t	<p><u>SITC of V-900 PNG Gas Burner</u></p> <p>SITC of V-900 PNG Gas Burner</p> <ul style="list-style-type: none">(i) optimum working pressure 4.5psig(ii) Consumption per hour 1.580 Kgs(iii) Ribbon length 900mm(iv) Rated heat output 17650kcal/hr. <p>These burner can be made with bottom or side entry injectors, in the centre of the burners .</p>  <p><u>V-900 PNG Gas Burner</u></p>
21.	R2-ME-18-1-u	<p><u>SITC of V-1200 PNG Gas Burners</u></p> <p>SITC of T-1200 PNG Gas Burners</p> <ul style="list-style-type: none">1) optimum working pressure 4.5psig,2) Consumption per hour 1.580 Kgs,3) Length ribbon 1200mm,4) Rated heat output 17650kcal/hr. <p>These burners can be made with bottom or side entry injectors in the centre of the burner for the work with bottom or PNG Line.</p>

TECHNICAL SPECIFICATIONS M&E

22.

SITC of T-35 PNG Gas Burner

SITC of T-35 PNG Gas Burner

- (i) **consumption per hour 1.580 Kgs**
- (ii) **length 220mm, head dia 83mm**
- (iii) **Rated heat output 17650kcal/hr.**

These are heavy duty burners for use in general cooking, bulk frying and for general heating requirements. These burners are recommended to be used at a pressure of 0.3 kg/cm² (4.5 psig), however, this may be varied by $\pm 25\%$ the heat output being varied accordingly.

R2-ME-18-1-v



T-35 meet burner

TECHNICAL SPECIFICATIONS M&E

23.

SITC of Flame Arrestor 1 inch

Flame arrestor is safety devices for arresting and extinguishing flames travelling within pipelines containing flammable gases. They operate on the principle of reducing the flames speed, dissipating and absorbing the heat developed by it to lower the temperature to below that of ignition within the arrestor.

- a) Size: 1 Inch dia.
- End connection: Screwed / flanged #150 R.F.
 - Type : In Line / End of Line mounting
 - Body : Cast Steel
 - Flame Bank: Stainless Steel (S.S.304)
 - Gasket : CAF

R2-ME-18-1-w

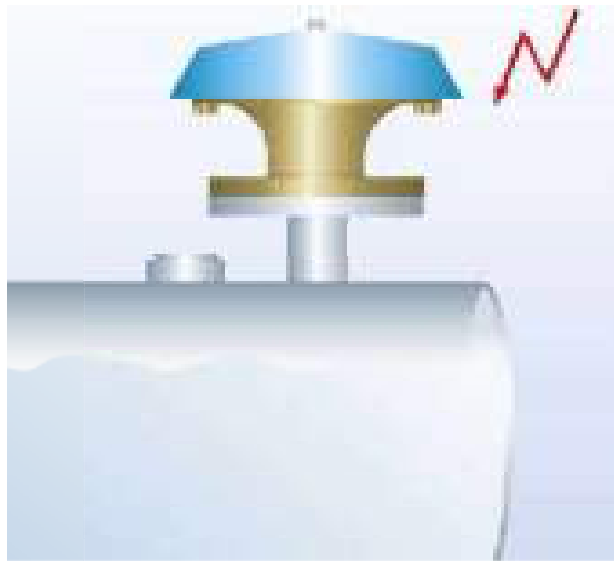

24.

R2-ME-18-1-x

SITC OF SS 3 Burner Gas Range

SS 3 Burner gas range of

- 1) **Type** - Freestanding
- 2) **Size** - 7.5X1.6X2 FT ,
- 3) **Frame work** - SS 304 Square Bar of standard ASTM A276 Size 1 Inch Grade SWG 18
- 4) **Outer Body** - SS 304 Stainless Steel role Sheet of Grade SWG 18 is fabricated, Covered and polished around the surrounding of frame
- 5) **Control type** - Needle Valve of 1/2" Size
- 6) **Medium** - Natural Gas/ LPG
- 7) **Conversion** - Needed as the Medium Changes
- 8) **Burner Types** - Drum Burners

Drum Burners

- 9) **Burner Pressure-** 4.5 PSIG
- 10) **Consumption Rate-** 2.580 KG/Hr
- 11) **Rated Heat-**117600 Btu/hr
- 12) **Manifol-** 1/2" SS 304 Seamless pipe is fixed and fabricated with two end is fixed with end plug
- 13) **Pigtail -** Copper Pipe with both the ends are fixed with female type nuts
- 14) **Pin** - Loose Pin is fabricated over Manifold and pigtail is connected to pin



TECHNICAL SPECIFICATIONS M&E

25.

R2-ME-18-1-y

SITC OF SS Single Burner Gas Range

SS Single Burner gas range of

- n) Type - Freestanding
- o) Size - 1.5X1.5X1.6 FT ,
- p) Frame work - SS 304 Square Bar of standard ASTM A276 Size 1 Inch Grade SWG 18
- q) Outer Body - SS 304 Stainless Steel role Sheet of Grade SWG 18 is fabricated, Covered and polished around the surrounding of frame
- r) Control type - Needle Valve of 1/2" Size
- s) Medium - Natural Gas/ LPG
- t) Conversion - Needed as the Medium Changes
- u) Burner Types - Drum Burners

Drum Burners

- v) Burner Pressure- 4.5 PSIG
- w) Consumption Rate- 2.580 KG/Hr
- x) Rated Heat- 117600 Btu/hr
- y) Manifold- 1/2" SS 304 Seamless pipe is fixed and fabricated with two end is fixed with end plug
- z) Pigtail - Copper Pipe with both the ends are fixed with female type nuts
- aa) Pin- Loose Pin is fabricated over Manifold and pigtail is connected to pin



TECHNICAL SPECIFICATIONS M&E

26.

SITC OF SS Plate Gas Range

SS Plate Burner Gas Range of

- (i) Type Freestanding
- (ii) Size 4.5X1.5X2.5 FT ,
- (iii) Frame work - SS 304 Square Bar of standard ASTM A276 Size 1 Inch Grade SWG 18
- (iv) Outer Body - SS 304 Stainless Steel role Sheet of Grade SWG 18 is fabricated, Covered and polished around the surrounding of frame and M.S Plate (Tawa)
- (v) Control type - Needle Valve of 1/2" Size
- (vi) Medium - Natural Gas/ LPG
- (vii) Conversion - Needed as the Medium Changes
- (viii) Burner Types - V type Burner of V-600
- (ix) G-09 or Single Drum Burner

V Type Burner of V-600

- (x) Burner Pressure - 4.5 PSIG
- (xi) Consumption Rate - 1.580 KG/Hr
- (xii) Rated Heat- 70000 Btu/hr

G-09 Burner

- (xiii) Burner Pressure- 4.5 PSIG
- (xiv) Consumption Rate- 2.580 KG/Hr
- (xv) Rated Heat- 117600 Btu/hr
- (xvi) Manifold- 1/2" SS 304 Seamless pipe is fixed and fabricated with two end is fixed with end plug
- (xvii) Pigtail- Copper Pipe with both the ends are fixed with female type nuts
- (xviii) Pin- Loose Pin is fabricated over Manifold and pigtail is connected to pin

R2-ME-18-1-z



TECHNICAL SPECIFICATIONS M&E

27.

SITC of Methane gas detector of 10 channel

SITC of Methane gas detector of 10 channel having alarm system on gas detection

1. Make : TRITECH / EQUIVALENT/Uniphos
2. Sensor: Catalytic
3. Buzzer: In Built
4. Power Supply : 230 v AC
5. Enclosure / Mounting : Reinforced Plastic / wall mounting type
6. No Of Channels : As required
7. Control Cables : 1.5 MM2 * 3 Core

R2-ME-18-1-aa



TECHNICAL SPECIFICATIONS M&E

28.	R2-ME-18-1-bb	<p><u>SITC of methane gas detector Head/sensor</u></p> <p>Supply, installation, testing & Commissioning of gas sensor Transmitter with CMRI Certified Catalytic Bead sensor; Local Alarm Status Display, Relay output, housed in a CMRI Certified Flameproof Enclosure (IIA/IIB)</p> <ul style="list-style-type: none">(i) Make : TRITECH / Honeywell/Uniphos(ii) Sensor Type: Pellistor, Catalytic combustion (diffusion)(iii) Range : 0 -100 % LEL HC(iv) Detector : Stainless Steel(v) Protection : Flame / explosion proof certified(vi) Mounting : Weather(vii) Proof with Flame proof Gland
29.	R2-ME-18-1-cc	<p><u>S&F P&F Cu unarmoured 4CX1.5sq.mm</u></p> <p>Providing & Fixing of Flexible & unarmoured 4CX1.5sq.mm : IS463 Instrument & power cable required for Installation, Testing, Commissioning of PNG GAS LEAK DETECTION SYSTEM including required accessories, Fasteners, Supports etc.</p>

30.

R2-ME-18-1-dd

SITC OF PRESSURE GAUGE

SITC of Pressure Gauge with necessary fittings.

- a) **Type : Diaphragm Type**
- b) **Manufacturer: H .Guru / Waree / etc.**
- c) **Material of Construction**
- d) a) **Case : S.S. 304**
- e) **Block MovementMaterial:S.S.304**
- f) c) **Bourdon Material: S.S. 316**
- g) **Dial Size : 1 00 mm**
- h) **Accuracy : $\pm 1\%$ of FS**
- i) **ORP : 1 30%**
- j) **Gasket: Neoprine**
- k) **Range : 0 – 100 bar**
- l) **Mounting : Direct with Bottom Entry**
- m) **Glass : Plain**



Pressure gauge

TECHNICAL SPECIFICATIONS M&E

31.	R2-ME-18-1-ee	<p><u>SITC OF Gas train</u></p> <p><u>PRS SYSTEM</u></p> <p>Pressure regulating station (PRS) /Gas trains are required to supply certain quantity of gas at specific operating pressure. The PRS/ Gas trains essentially performs a safety function i.e. limit the downstream pressure up to pre-determined set point though inlet pressure varies between maximum to minimum</p> <p><u>Pressure Reducing System</u></p> <p>Inlet Pressure: 1 bar to 4 bar</p> <p>Outlet Pressure: 100 mbar</p> <p><u>Features of PRS System</u></p> <ul style="list-style-type: none">● Its main function is to regulate the proper gas flow within system set pressure.● If the Pressure arises inside the system suddenly, the Slam Shut Off Valve will shut off the whole system without causing any damage to Gas Pressure Regulator.● In the PRS system to remove dust particles in the gas. It has filters of 50 micron. No pressure reduction of gas occurs while passing through the filter.● Flame arrestor is fitted at the start of the PRS system to prevent any transmission of flame in the line.● Pressure Gauge are provided at the start and the end of the PRS system to monitor the pressure in the line.● The pressure regulators and Safety Valves are function itself, so that this function does not require any external power source i.e. comp. air or electrical supply● High quality Valves are used which ensure reliability of the system.
-----	---------------	--

TECHNICAL SPECIFICATIONS M&E

32.

SITC OF Solenoid Valves

- (1) **Type- 2/2- way pilot operated. Diaphragm Type Normally opens energized**
- (2) **End Connection- Screw to BSP (F)**
- (3) **Body- S.S. ASTM A.351 Gr. CF8M**
- (4) **Diaphragm Seat- Buna Nitrile**
- (5) **Max Inlet pressure-1-4 bar**
- (6) **Max Operating Temperature- 60°C**
- (7) **Coil Voltage- Standard- 230 Volts, 50Hz A.C.**
- (8) **Duty Cycle- Continuous**
- (9) **Coil Insulation- H Class**
- (10) **Coil Protection- FLP-IIC**

R2-ME-18-1-ff



TECHNICAL SPECIFICATIONS M&E

SITC OF 3 INCH SEAMLESS PIPE AS PER SCH40:-

SITC of 3 inch dia. MS seamless pipe as per SCH40. MS seamless pipe shall be as per ASTM A-106 Gr. B Sch. 40 with seamless fitting like elbow, reducers and tees etc., construction rates shall include fabrication & erection of support, testing with compressed air at 4kg/cm², stenciling, two coated of (golden yellow) paint approved by Mahanagar Gas Board etc.

SITC OF 2 INCH SEAMLESS PIPE AS PER SCH40 :-

SITC of 2 inch dia. MS seamless pipe as per SCH40. MS seamless pipe shall be as per ASTM A-106 Gr. B Sch. 40 with seamless fitting like elbow, reducers and tees etc., construction rates shall include fabrication & erection of support, testing with compressed air at 4kg/cm², stenciling, two coated of (golden yellow) paint approved by Mahanagar Gas Board etc.

SITC OF 1 INCH SEAMLESS PIPE AS PER SCH40 :-

SITC of 1 inch dia. MS seamless pipe as per SCH40. MS seamless pipe shall be as per ASTM A-106 Gr. B Sch. 40 with seamless fitting like elbow, reducers and tees etc., construction rates shall include fabrication & erection of support, testing with compressed air at 4kg/cm², stenciling, two coated of (golden yellow) paint approved by Mahanagar Gas Board etc.

SITC OF 3 INCH DIA. (FLANGED END) MANUAL CUT-OFF BALL VALVE, FIRE SAFE DESIGN, FLANGED:-

SITC of 3 inch dia. (flanged end) Manual cut-off Ball Valve, fire safe design, flanged as per ASA 150# standard. For operating of gas distribution system, Use gun metal bore ball valve as per specification duly confirmed by M/s Mahanagar Gas Ltd. Only approved make valves shall be used in pipeline network. Flanges shall be fixed with G.I stud nut bolts & washers of suitable size. Ball valves are to be used for isolation of equipment's/components. The valves are full bore design only. The seat will be of PTFE. The valve design will be as per BS: 5351/ API: 6D

SITC OF 2 INCH DIA. (FLANGED END) MANUAL CUT-OFF BALL VALVE, FIRE SAFE DESIGN, FLANGED :-

SITC of 2 inch dia. (flanged end) Manual cut-off Ball Valve, fire safe design, flanged as per ASA 150# standard. For operating of gas distribution system, Use gun metal bore ball valve

TECHNICAL SPECIFICATIONS M&E

as per specification duly confirmed by M/s Mahanagar Gas Ltd. Only approved make valves shall be used in pipeline network. Flanges shall be fixed with G.I stud nut bolts & washers of suitable size. Ball valves are to be used for isolation of equipment's/components. The valves are full bore design only. The seat will be of PTFE. The valve design will be as per BS: 5351/ API: 6D.

SITC OF 1 INCH DIA. (FLANGED END) MANUAL CUT-OFF BALL VALVE, FIRE SAFE DESIGN, FLANGED

SITC of 1 inch dia. (flanged end) Manual cut-off Ball Valve, fire safe design, flanged as per ASA 150# standard. For operating of gas distribution system, Use gun metal bore ball valve as per specification duly confirmed by M/s Mahanagar Gas Ltd. Only approved make valves shall be used in pipeline network. Flanges shall be fixed with G.I stud nut bolts & washers of suitable size. Ball valves are to be used for isolation of equipment's/components. The valves are full bore design only. The seat will be of PTFE. The valve design will be as per BS: 5351/ API: 6D.

SITC of MS flange of 3 inch Dia.

SITC of MS flange of 3 inch Dia., Flanges shall be used at each valve location and it shall be use according to ball valve size. Ball Valve and Flange shall be fixed with G.I Stud nut bolts & washer of suitable size.

- Material- ASME B 16.5
- Dimensions- ANSI B.16.5
- Rating / Wall Thickness- 150 lbs
- Construction- Machined
- Joint Type- Slip-on
- Face- Raised Face

SITC of MS flange of 2 inch Dia

SITC of MS flange of 2 inch Dia, Flanges shall be used at each valve location and it shall be use according to ball valve size. Ball Valve and Flange shall be fixed with G.I Stud nut bolts & washer of suitable size.

- Material- ASME B 16.5
- Dimensions- ANSI B.16.5

TECHNICAL SPECIFICATIONS M&E

- Rating / Wall Thickness- 150 lbs
- Construction- Machined
- Joint Type- Slip-on
- Face- Raised Face

SITC of MS flange of 1 inch Dia :-

SITC of MS flange of 1 inch Dia., Flanges shall be used at each valve location and it shall be use according to ball valve size. Ball Valve and Flange shall be fixed with G.I Stud nut bolts & washer of suitable size.

- Material- ASME B 16.5
- Dimensions- ANSI B.16.5
- Rating / Wall Thickness- 150 lbs
- Construction- Machined
- Joint Type- Slip-on
- Face- Raised Face

Design and Co-ordination with MGL per Meter :-

The design and installment which is proposed should meet the guaranteed and satisfactory performance requirements according to M/s Mahanagar Gas Ltd (MGL) operation and maintenance department and/or any government or non-government undertaking/agency. This includes compliance of fulfilling all the norms for commissioning of a gas Meter for the supply of natural gas from M/s MahanagarGas Ltd. (MGL) and /or respective government non-government undertaking/agency. Installed system will be approved and taken-over by MCGM for regular operation only after satisfactory performance testing in all respect & clearance from from M/s Mahanagar Gas Ltd (MGL). Approval/clearance from M/s Mahanagar Gas Ltd (MGL) shall be in the scope of contract.

SITC of Hydraulic flexible hose pipe :-

SITC of Hydraulic flexible hose pipe of suitable size including required fittings etc. The hydraulic flexible hose pipe shall be as per the BIS 9573 [type 2].

Construction:

- Inner Tube:Seamless inner tube of LPG synthetic rubber.

TECHNICAL SPECIFICATIONS M&E

- Reinforcement: Textile braids below a layer of brass-coated high tensile steel wire.
- Outer Cover: Weather abrasion, atmospheric exposure resistant synthetic rubber cover.
- Temperature: -20°C to +45°C. • Application: For high pressure.
- End Connection: Swaged or Crimped or Reusable type.

SITC of Gas pressure Regulator:-

SITC of Gas pressure Regulator of size 25mm (Nominal Bore) for gas pressure from 100 mbar to 30 (make: United / Vanaz or equivalent).

- Type- 1st stage
- Color- Blue
- Thread Size- Inlet F.E.C.V. and Outlet 3/8: BSPFF
- Inlet pressure- 0.35-2.1kg/cm²
- Delivery pressure 0.035 kg/cm²
- Flow rate- 1.50 Kg/hr.

SITC of Manual Needle valve:-

SITC of Manual Needle valve with Long Spindle can be used for high & low pressure operation and come with a forged brass.

- Material: Brass
- Size: 3/8" X 3/8" or depending upon the requirements

SITC of Stainless Steel Gas Stove suitable for PNG gas :-

SITC of Stainless Steel Gas Stove suitable for PNG gas

SS Gas Stove of

- Size: 1X1 (LXB)
- Frame work: SS 304 Square Bar of standard ASTM A276 Size 1 Inch Grade SWG 18
- Outer Body : SS 304 Stainless Steel role Sheet of Grade SWG 18 is fabricated, Covered and polished around the surrounding of frame
- Control type: Needle Valve of 1/2" Size
- Medium Natural Gas/ LPG

TECHNICAL SPECIFICATIONS M&E

- Conversion: Needed as the Medium Changes
- Burner Types: G-09
- Burner Pressure: 4 PSIG
- Consumption Rate:1.5KG/Hr
- Rated Heat:90000 Btu/hr

SITC of PNG Gas Pencil Burner suitable for PNG gas:-

SITC of PNG Gas Pencil Burner suitable for PNG gas with one way / two / four way arrangement as per site requirements

Dimension

- Length- 150mm
- Base diameter- 80mm
- Optimum working pressure: 0.035kg/cm²
- Consumption per hour- 0.1 kgs
- Rated Heat Output- 680 kcal/hr.

SITC of T-50 PNG Gas Burner :-

- consumption per hour 1.580 Kgs
- length 250mm, head dia 96mm
- Rated heat output 25200kcal/hr.

These are heavy duty burners for use in general cooking, bulk frying and for general heating requirements. These burners are recommended to be used at a pressure of 0.3kg/cm² (4.5 psig), however, this may be varied by $\pm 25\%$ the heat output being varied accordingly.

SITC of T-78 PNG Gas Burner:-

SITC of T-78 PNG Gas Burner

- consumption per hour 1.580 Kgs
- length 220mm, head dia 83mm
- Rated heat output 40350kcal/hr.

TECHNICAL SPECIFICATIONS M&E

These are heavy duty burners for use in general cooking, bulk frying and for general heating requirements. These burners are recommended to be used at a pressure of 0.3kg/cm² (4.5 psig), however, this may be varied by $\pm 25\%$ the heat output being varied accordingly.

SITC of Domestic Gas Burner :-

These are heavy duty burners for use in general cooking, bulk frying and for general heating requirements. These burners are recommended to be used at a pressure of 0.3 kg /cm² (4.5 psig), however, this may be varied by $\pm 25\%$ the heat output being varied accordingly. The consumption per hour for this type of burner is 1.20 Kgs with head dia. of 60mm Rated heat output 9500 kcal/hr

SITC of T-35 Drum meet PNG Gas Burner :-

SITC of Drum PNG Gas Burner

- consumption per hour 1.580 Kgs
- head dia 60mm
- Rated heat output 15500kcal/hr.

These are heavy duty burners for use in general cooking, bulk frying and for general heating requirements. These burners are recommended to be used at a pressure of 0.3 kg/cm² (4.5 psig), however, this may be varied by $\pm 25\%$ the heat output being varied accordingly.

SITC of V-900 PNG Gas Burner :-

SITC of V-900 PNG Gas Burner

- optimum working pressure 4.5psig
- Consumption per hour 1.580 Kgs
- Ribbon length 900mm
- Rated heat output 17650kcal/hr.

These burner can be made with bottom or side entry injectors, in the centre of the burners.

SITC of V-1200 PNG Gas Burner :-

SITC of V-1200 PNG Gas Burners

- optimum working pressure 4.5psig,
- Consumption per hour 1.580 Kgs,

TECHNICAL SPECIFICATIONS M&E

- Length ribbon 1200mm,
- Rated heat output 17650kcal/hr.

These burners can be made with bottom or side entry injectors in the centre of the burner for the work with bottom or PNG Line.

SITC of T-35 PNG Gas Burner

SITC of T-35 PNG Gas Burner

- consumption per hour 1.580 Kgs
- length 220mm, head dia 83mm
- Rated heat output 17650kcal/hr.

These are heavy duty burners for use in general cooking, bulk frying and for general heating requirements. These burners are recommended to be used at a pressure of 0.3 kg/cm² (4.5 psig), however, this may be varied by $\pm 25\%$ the heat output being varied accordingly.

SITC of Flame Arrestor (1 inch dia.).

SITC of Flame Arrestor (1 inch dia.). A Flame Arrestor is a passive safety device which prevents the propagation of a flame in a pipeline & arresting and extinguishing flames travelling within pipelines containing flammable gases into a defined volume or out of a defined volume. They operate on the principle of reducing the flames speed, dissipating and absorbing the heat developed by it to lower the temperature to below that of ignition within the arrestor. The flame arrestor shall be of type R9102 (1 Inch dia.). The end connection provided in this device shall be of Screw type. The type of mounting shall be In Line or End of Line mounting. The Body shall be made up of Cast Steel & Flame Bank shall be made up of Stainless Steel (S.S.304). The maximum pressure for this device is 1 - 19 Kg/cm². The end connections shall be 1/2" to 1" BSP (INT). The gas used in this device is LPG, Natural gas.

SITC of SS 3 Gas burner:-

SITC OF SS 3 Burner Gas Range :-

SS 3 Burner gas range of

- Type- Freestanding
- Size-7.5X1.6X2 FT ,
- Frame work-SS 304 Square Bar of standard ASTM A276 Size 1 Inch Grade SWG 18

TECHNICAL SPECIFICATIONS M&E

- Outer Body-SS 304 Stainless Steel role Sheet of Grade SWG 18 is fabricated, Covered and polished around the surrounding of frame
- Control type-Needle Valve of ½” Size
- Medium-Natural Gas/ LPG
- Conversion-Needed as the Medium Changes
- Burner Types-Drum Burners

Drum Burners

- Burner Pressure-4.5 PSIG
- Consumption Rate- 2.580 KG/Hr
- Rated Heat-117600 Btu/hr
- Manifold-½” SS 304 Seamless pipe is fixed and fabricated with two end is fixed with end plug
- Pigtail-Copper Pipe with both the ends are fixed with female type nuts
- Pin-Loose Pin is fabricated over Manifold and pigtail is connected to pin.

SITC of SS single gas burner :-

SITC of SS single gas burner SS Single Burner gas range of

- Type-Freestanding
- Size-1.5X1.5X1.6 FT,
- Frame work-SS 304 Square Bar of standard ASTM A276 Size 1 Inch Grade SWG 18
- Outer Body-SS 304 Stainless Steel role Sheet of Grade SWG 18 is fabricated, Covered and polished around the surrounding of frame
- Control type-Needle Valve of ½” Size
- Medium-Natural Gas/ LPG
- Conversion-Needed as the Medium Changes
- Burner Types-Drum Burners
- Drum Burners
- Burner Pressure-4.5 PSIG
- Consumption Rate-2.580 KG/Hr.

TECHNICAL SPECIFICATIONS M&E

- Rated Heat-117600 Btu/hr.
- Manifold-1/2" SS 304 Seamless pipe is fixed and fabricated with two ends is fixed with end plug
- Pigtail-Copper Pipe with both the ends are fixed with female type nuts
- Pin-Loose Pin is fabricated over Manifold and pigtail is connected to pin.

SITC of SS plate gas burner :-

SITC of SS plate gas burner. SS Plate Burner Gas Range of

- Type-Freestanding
- Size-4.5X1.5X2.5 FT
- Frame work-SS 304 Square Bar of standard ASTM A276 Size 1 Inch Grade SWG 18
- Outer Body-SS 304 Stainless Steel role Sheet of Grade SWG 18 is fabricated, Covered and polished around the surrounding of frame and M.S Plate (Tawa)
- Control type-Needle Valve of 1/2" Size
- Medium-Natural Gas/ LPG
- Conversion-Needed as the Medium Changes
- Manifold-1/2" SS 304 Seamless pipe is fixed and fabricated with two end is fixed with end plug
- Pigtail-Copper Pipe with both the ends are fixed with female type nuts
- Pin-Loose Pin is fabricated over Manifold and pigtail is connected to pin
- Burner Type-V type Burner of V-600/ G-09

V Type Burner

- V Type Burner of V-600
- Burner Pressure-4.5 PSIG
- Consumption Rate-1.580 KG/hr.
- Rated Heat-70000 Btu/hr.

G-09 Burner

- Burner Pressure-4.5 PSIG

TECHNICAL SPECIFICATIONS M&E

- Consumption Rate-2.580 KG/hr.
- Rated Heat-117600 Btu/hr.

SITC of Methane gas detector pannel of 10 channel:-

SITC of Methane gas detector pannel of 10 channel having alarm system on gas detection

- Make:TRITECH / EQUIVALENT/Uniphos
- Sensor:Catalytic
- Buzzer:In Built
- Power Supply-230 V AC
- Enclosure / Mounting- Reinforced Plastic / wall mounting type
- No Of Channels-As required
- Control Cables-1.5 MM2 * 3 Cores

Providing & Fixing Cu unarmoured 4Cx1.5sq.mm :-

Providing & Fixing of Flexible Cu unarmored cable.(4CX1.5sq.mm : IS463)

Power cable required for Installation, Testing, Commissioning of PNG GAS LEAK DETECTION SYSTEM including required accessories, Fasteners, Supports etc.

SITC of Pressure Gauge with necessary fittings :-

SITC of Pressure Gauge with necessary fittings and the range of this pressure gauge shall be 0-600 mbar, and the dial size is 4 inches.

- Type- Diaphragm Type
- Manufacturer- H .Guru / Waree / etc.
- Material of Construction
 - a) Case- S.S. 304
 - • Block Movement Material- S.S.304
 - • c) Bourdon Material- S.S. 316
- Dial Size- 1 00 mm
- Accuracy- $\pm 1\%$ of FS
- Gasket- Neoprine

TECHNICAL SPECIFICATIONS M&E

- Range- 0 – 1 bar
- Mounting- Direct with Bottom Entry
- Glass- Plain

SITC OF SITC OF Gas train

PRS SYSTEM

Pressure regulating station (PRS) /Gas trains are required to supply certain quantity of gas at specific operating pressure. The PRS/ Gas trains essentially performs a safety function i.e. limit the downstream pressure up to pre-dertmind set point though inlet pressure varies between maximum to minimum

Pressure Reducing System

Inlet Pressure: 1 bar to 4 bar

Outlet Pressure: 100 mbar

Features of PRS System

1. Its main function is to regulate the proper gas flow within system set pressure.
2. If the Pressure arises inside the system suddenly, the Slam Shut Off Valve will shut off the whole system without causing any damage to Gas Pressure Regulator.
3. In the PRS system to remove dust particles in the gas. It has filters of 50 micron. No pressure reduction of gas occurs while passing through the filter.
4. Flame arrestor is fitted at the start of the PRS system to prevent any transmission of flame in the line.
5. Pressure Gauge are provided at the start and the end of the PRS system to monitor the pressure in the line.
6. The pressure regulators and Safety Valves are function itself, so that this function does not require any external power source i.e. comp. air or electrical supply
7. High quality Valves are used which ensure reliability of the system PRS SYSTEM :-

SITC OF Solenoid Valves

- Type- 2/2 way pilot operated. Diaphragm Type Normally opens energized
- 2. End Connection- Screw to BSP (F)

TECHNICAL SPECIFICATIONS M&E

- 3. Body-S.S. ASTM A.351 Gr. CF8M
- 4. Diaphragm Seat-Buna Nitrile
- 5. Max Inlet pressure-1-4 bar
- 6. Max Operating Temp.-60°C
- 7. Coil Voltage- Standard- 230 Volts, 50Hz A.C.
- 8. Duty Cycle-Continuous
- 9. Coil Insulation-H Class
- 10. Coil Protection-FLP-IICC OF Solenoid Valves

SITC of natural gas geyser :-

SITC of Natural Gas Geyser of 5 Ltr capacity with required fittings Make-ISI approved.

1. Gas Type-Natural Gas
2. Heat Input (kW)-12
3. Capacity (L/min)-5
4. Rated Gas Pressure (kN/m²)-2.0 NG
5. Efficiency->=80%
6. Operating Water Pressure (Bar)-Up to 8 bar
7. Ignition Mode-Direct Ignition-ionization flame control.
8. Minimum Starting Water Pressure (Bar)-0.07 bar
9. Rated Voltage (V) (one battery)-DC 3V (2 Batteries)

SITC of 90mm NB diameter (SDDR-11) polyethene :-

SITC of 90mm NB Dia SDDR-11 Poly Ethelene pipe including PE fitting like Elbow, Reducer etc., ISO: 4437/ IS: 14885 standards, specification of polyethylene pipes, warning tape, construction rate are include with fusion welding and supports, testing with compressed air 4 kg/cm². All the pipe and fittings are MGL approved.

SITC of safety routing of trench for MDPE PNG upstream pipeline with its accessories and fitting etc. :-

SITC of safety routing trench for MDPE PNG upstream pipeline includes the excavation, providing U block tiles, RCC tiles and indicating tiles, warning tape, PCC, backfilling etc. with

TECHNICAL SPECIFICATIONS M&E

necessary accessories and fittings for high pressure gas pipeline as per MGL safety norms and standards.

Removal of MS 3" dia. A-106 Gr. B Sch 40:-

Removal of Old/Damaged/Existing M.S. PIPE 3 inch dia. A-106 Gr. B Sch 40 includes of brackets, supports & u clamp etc. with the help of Man power, Grinder machine, Cutter shall be removed without damaging the existing networks, walls, ceilings etc. in neat manner. The holes/patches etc. shall be made good. Dust and dirt sprayed due to work of removal shall be removed and the premises shall be cleaned properly.

Removal of MS 2" dia. A-106 Gr. B Sch 40:-

Removal of Old/Damaged/Existing M.S. PIPE 2 inch dia. A-106 Gr. B Sch 40 includes of brackets, supports & u clamp etc. with the help of Man power, Grinder machine, Cutter shall be removed without damaging the existing networks, walls, ceilings etc. in neat manner. The holes/patches etc. shall be made good. Dust and dirt sprayed due to work of removal shall be removed and the premises shall be cleaned properly.

Removal of MS 1" dia. A-106 Gr. B Sch 40 :-

Removal of Old/Damaged/Existing M.S. PIPE 1 inch dia. A-106 Gr. B Sch 40 includes of brackets, supports & u clamp etc. with the help of Man power, Grinder machine, Cutter shall be removed without damaging the existing networks, walls, ceilings etc. in neat manner. The holes/patches etc. shall be made good. Dust and dirt sprayed due to work of removal shall be removed and the premises shall be cleaned properly.

Removal of Ball Valve 3" dia.:-

Removal of Old/Damaged/Existing Ball Valve 3 inch dia. includes of flanges, barrel nipples, gasket and stud bolt & nut etc. with the help of Man power & tools etc. shall be removed without damaging the existing networks, walls, ceilings etc. in neat manner.

Removal of Ball Valve 2" dia.:-

Removal of Old/Damaged/Existing Ball Valve 2 inch dia. includes of flanges, barrel nipples, gasket and stud bolt & nut etc. with the help of Man power & tools etc. shall be removed without damaging the existing networks, walls, ceilings etc. in neat manner.

Removal of Ball Valve 1" dia.:-

TECHNICAL SPECIFICATIONS M&E

Removal of Old/Damaged/Existing Ball Valve 1 inch dia. includes of flanges, barrel nipples, gasket and stud bolt & nut etc. with the help of Man power & tools etc. shall be removed without damaging the existing networks, walls, ceilings etc. in neat manner.

Removal of Methane Gas Detector Panel :-

Removal of Old/Damaged/Existing Methane gas detector of 10 channel having alarm system on gas detection includes of electric power supply board etc. with the help of Man power & tools etc. shall be removed without damaging the existing networks, walls, ceilings etc. in neat manner.

Removal of Methane Gas Detector Sensor :-

Removal of Old/Damaged/Existing Methane Gas Sensor Transmitter with CMRI Certified Catalytic Bead Sensor, Local Alarm Status Display, Relay Output, housed in a CMRI Certified Flameproof Enclosure (IIA/IIB) with the help of Man power & tools etc. shall be removed without damaging the existing networks, walls, ceilings etc. in neat manner.

Removal & Refixing of MS Pipe 3" dia. :-

Removal & Refixing of Old/Damaged/Existing M.S. PIPE 3 inch dia. A-106 Gr. B Sch 40 includes of brackets, supports & u clamp etc. with the help of Man power, Grinder machine, Cutting & welding Machine shall be removed & refixing without damaging the existing networks, walls, ceilings etc. in neat manner. The holes/patches etc. shall be made good. Dust and dirt sprayed due to work of removal shall be removed and the premises shall be cleaned properly.

Removal & Refixing of MS Pipe 2" dia

Removal & Refixing of Old/Damaged/Existing M.S. PIPE 2 inch dia. A-106 Gr. B Sch 40 includes of brackets, supports & u clamp etc. with the help of Man power, Grinder machine, Cutting & welding Machine shall be removed & refixing without damaging the existing networks, walls, ceilings etc. in neat manner. The holes/patches etc. shall be made good. Dust and dirt sprayed due to work of removal shall be removed and the premises shall be cleaned properly.

Removal & Refixing of MS Pipe 1" dia. :-

Removal & Refixing of Old/Damaged/Existing M.S. PIPE 1 inch dia. A-106 Gr. B Sch 40 includes of brackets, supports & u clamp etc. with the help of Man power, Grinder machine, Cutting & welding Machine shall be removed & refixing without damaging the existing

TECHNICAL SPECIFICATIONS M&E

networks, walls, ceilings etc. in neat manner. The holes/patches etc. shall be made good. Dust and dirt sprayed due to work of removal shall be removed and the premises shall be cleaned properly.

Painting of MS Pipe 3" dia. :-

Removal of 3 inch pipe Old/existing rust/dirt/dust/moisture/paint by using scrubbing, polishing/reconditioning if required and apply coat of red oxide & two coats of synthetic enamel epoxy paint and stenciling as per MGL norm & condition with the help of Man power & tools etc. shall be painting without disturbing walls, ceilings etc. in neat manner

Painting of MS Pipe 2" dia. :-

Removal of 2 inch pipe Old/existing rust/dirt/dust/moisture/paint by using scrubbing, polishing/reconditioning if required and apply coat of red oxide & two coats of synthetic enamel epoxy paint and stenciling as per MGL norm & condition with the help of Man power & tools etc. shall be painting without disturbing walls, ceilings etc. in neat manner

Painting of MS Pipe 1" dia. :-

Removal of 1 inch pipe Old/existing rust/dirt/dust/moisture/paint by using scrubbing, polishing/reconditioning if required and apply coat of red oxide & two coats of synthetic enamel epoxy paint and stenciling as per MGL norm & condition with the help of Man power & tools etc. shall be painting without disturbing walls, ceilings etc. in neat manner.

Rebate of Ball Valve 3" dia. :-

Rebate of old/damaged/existing 3 inch dia. (Flanged End) Manual Cut-off Ball Valve

Rebate of Ball Valve 2" dia. :-

Rebate of old/damaged/existing 2 inch dia. (Flanged End) Manual Cut-off Ball Valve.

Rebate of Ball Valve 1" dia. :-

Rebate of old/damaged/existing 1 inch dia. (Flanged End) Manual Cut-off Ball Valve.

Calibration of Methane Gas Detector Head/Sensor work for a year :-

Calibration of Methane Gas Detector:

Remove the sensor of gas detector & send for third party calibration testing and fix the sensor in gas detector & test the Bump test with Methane gas. Submit the third party calibration test certificate.

TECHNICAL SPECIFICATIONS M&E

Clean all the Gas detector parts set etc. and examining the function of equipment for satisfactory performance according to Gas pressure.

Servicing & Maintenance of PNG SS Stove work once in month :-

Servicing & Maintenance of PNG SS Stove work once in month

Clean the all PNG base Gas shegadi, equipment's & burners sets etc. and examining the function of burners for satisfactory performance according to Gas pressure. Clean the all joints and accessories connected to equipment sets. Check the all gaskets & packing position. The burner caps are cleaning with use wire brushes and warm water removed the substance dries inside the burners. Check the performance of the burner after servicing i.e. pressure etc.

Servicing & Testing of MGL Meter work once in a year. :-

Servicing & Testing of MGL Meter work once in year.

Gas meter test on 100 milibar pressure. Paint PNG Gas meter once in Year. The meter shall be cleaned thoroughly by following proper procedure before painting. The meter shall be painted with one coat of anticorrosive primer paint and two coats of epoxy paint. (Shade as per MGL Approved make only)

MGL Signboards of Shut-off Valve, Isolation Valve, Do not Dig, Emergency Board and No Smoking of Sizes as per the MGL norm:-

MGL Signboards of Shut-off Valve, Isolation Valve, Do not Dig, Emergency Board and No Smoking of Sizes as per the MGL norm.

Servicing & Maintenance of PNG T-78 Burner with its accessories work once in month

:-

Servicing & Maintenance of PNG T-78 Burner with its accessories work once in month.

To clean the all PNG base Gas burners sets etc. and examining the function of burners for satisfactory performance according to Gas pressure. Clean the all joints and accessories connected to equipment sets.

To check the all gaskets & packing position. The burner caps are cleaning with use wire brushes and warm water removed the substance dries inside the burners. Check the performance of the burner after servicing i.e. pressure etc.

Servicing & Maintenance of PNG T-50 Burner with its accessories work once in month:-

TECHNICAL SPECIFICATIONS M&E

Servicing & Maintenance of PNG T-50 Burner with its accessories work once in month.

To clean the all PNG base Gas burners sets etc. and examining the function of burners for satisfactory performance according to Gas pressure. Clean the all joints and accessories connected to equipment sets.

To check the all gaskets & packing position. The burner caps are cleaning with use wire brushes and warm water removed the substance dries inside the burners. Check the performance of the burner after servicing i.e. pressure etc.

Servicing & Maintenance of PNG T-35 Burner with its accessories work once in month

:-

Servicing & Maintenance of PNG T-35 Burner with its accessories work once in month.

To clean the all PNG base Gas burners sets etc. and examining the function of burners for satisfactory performance according to Gas pressure. Clean the all joints and accessories connected to equipment sets.

To check the all gaskets & packing position. The burner caps are cleaning with use wire brushes and warm water removed the substance dries inside the burners. Check the performance of the burner after servicing i.e. pressure etc.

Servicing & Maintenance of PNG V-1200 Burner with its accessories work once in month :-

Servicing & Maintenance of PNG V-1200 Burner with its accessories work once in month.

To clean the all PNG base Gas burners sets etc. and examining the function of burners for satisfactory performance according to Gas pressure. Clean the all joints and accessories connected to equipment sets.

To check the all gaskets & packing position. The burner caps are cleaning with use wire brushes and warm water removed the substance dries inside the burners. Check the performance of the burner after servicing i.e. pressure etc.

Servicing & Maintenance of PNG V-900 Burner with its accessories work once in month:-

Servicing & Maintenance of PNG V-900 Burner with its accessories work once in month.

To clean the all PNG base Gas burners sets etc. and examining the function of burners for satisfactory performance according to Gas pressure. Clean the all joints and accessories connected to equipment sets.

To check the all gaskets & packing position. The burner caps are cleaning with use wire

TECHNICAL SPECIFICATIONS M&E

brushes and warm water removed the substance dries inside the burners. Check the performance of the burner after servicing i.e. pressure etc.

Servicing & Maintenance of PNG Gas Geyser with its accessories work once in month:-

Servicing & Maintenance of PNG Gas Geyser work once in month

- Check all the safety devices like flame failure device, overheat protection device, gas and meter stability device and oxygen depletion sensor / incomplete combustion safety device
- Check all the electrical joints and accessories connected to equipment sets.
- To check the all gaskets & packing position.
- Examining the function of gas geyser for satisfactory performance according to Gas pressure.
- Check the performance of the gas geyser after servicing i.e. pressure etc.
- Change the battery if required.

Natural Gas Pipeline System

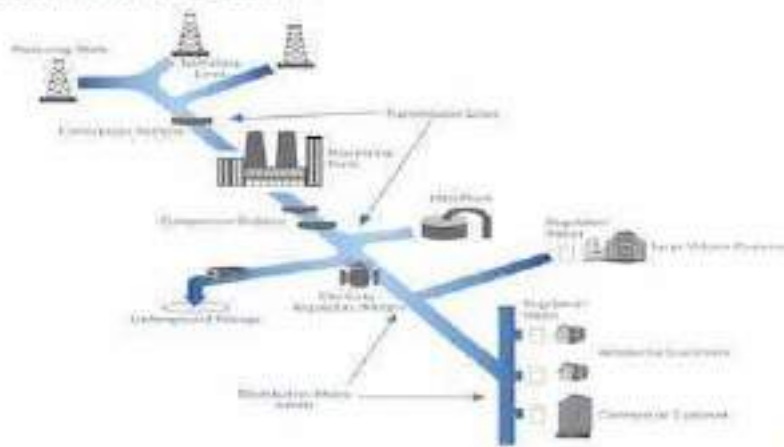

SP-ME-TS-67 TECHNICAL SPECIFICATIONS FOR SITC OF LIFTS

Passenger/ Passenger cum Stretcher lift (Hospital lift) /Goods lift

- 1) MR type lift:- The Lift Machinery shall be placed directly above the lift shaft in machine room on raised platform beam with Rolled Steel joints, supplied and installed by the contractors.
- 2) MRL type lift:- The Lift machinery shall be placed, as recommended by the Manufacturers, supplied and installed by the contractors.

1.1 DESIGN

The design of the equipment shall match the design & performance requirements as specified below.

1.1.1 PROVED DESIGN

The lift contractor shall develop the design based on the below specifications and on proven and reliable engineering practices. All sub systems & equipment shall be of proven design.

1.1.2 Design Criteria

The design of the equipment offered should meet the following criteria: -

- Rated Speed : 1 mps (or as per site requirement) for Passenger/ Passenger cum Stretcher lift (Hospital lift)
- Rated speed : 0.6 to 1 mps (or as per site requirement) for goods lift
- Usage of the latest state of the art technology.
- Design enhancements should not reduce the life cycle of equipment / components
- Design life of at least 20 years
- Highest levels of reliability& equipment availability
- Lowest maintenance cost
- Modular design
- Minimum life cycle cost
- High traceability of components through unique bar coding / serial nos. / tagging
- Lowest energy consumption
- Highest levels of safety
- Environment friendly
- Code compliance

1.1.3 DESIGN REQUIREMENT – LIFE CYCLE

The design of each component will achieve the minimum service life specified below:

-

- Ropes / Belts: - 8 years
- Over speed governor: - 20 years
- Traction machine / motor: - 20 years
- Door operator: - 20 years
- Safety gear / block: - 20 years
- Travelling cables: - 20 years
- Inverter Drive: - 20 years
- Buffer: - 20 years
- Controller & circuits: - 20 years
- Contactor / Relays: 10,00,000 operations

2. DRIVING MECHANISM & ACCESSORIES

2.1 Lift Machine:/Hoist Motor

The lift machine shall be gearless PMSM (Permanent Magnet Synchronous Machine) of suitable KW, 415 volts, 3 phase, 50 Hz AC supply with a voltage variation of +10% and – 10% and shall be placed directly above the hoist way on steel beams resting on machine room floor slab. The Permanent magnet synchronous Gearless, Energy Efficient, electric hoist motor of suitable KW with traction pulley, over speed safety Governor (OSG) electromagnetic brakes to be installed. It shall have bearing specially built for heavy duty hoisting service. The entire assembly mounted on adequate size girders duly fixed on shaft walls complete with main / diverter traction sheaves, suspension wire ropes, belts of adequate size & strength or as per manufacturer's standard.

The motor shall be conforming to relevant I.S. or International Standards and shall be able to withstand all the routine as well as type tests, as specified in I.S. or relevant International Standards.

It shall be also suitable for frequent reversals, high starting torque and low starting current with Class 'F' Insulation, Minimum of permissible, and operations per hour shall not be less than 120.

The motor shall be rated for 30 minutes continuous service with 115°C rise above ambient temperature. The motor noise shall not exceed 55 dB on No-Load. The motor vibration shall not exceed 0.45 m/sec on No-Load.

The motor shall be designed in such a way to withstand occasional over loading of one fourth of rated capacity.

TECHNICAL SPECIFICATIONS M&E

The motor shall have a good speed regulation under different conditions of loads. The windings shall be robust in design and adequately insulated for tropical climates and mechanically strengthened with double varnishing.

The motor of lift machine or the worm shaft shall be arranged so as to provide hand winding facilities, with suitable marking for up and down direction of travel of the lift cage. Electric motor shall be of suitable duty, energy efficient and working on 3 ph. A.C. 50 c/s electric supply.

The motor shall be installed using heavy duty channel of suitable size & using anti vibration rubber pads to damp vibration. The thickness of the rubber pad should be minimum 25 mm. The noise level shall not exceed 60 dB at one meter distance from Machine.

The lift machine shall have high efficiency, high power factor and low power consumption and shall be designed to withstand peak currents in lift duties. Resilient anti-vibration mountings of suitable design shall be provided to minimize vibration transmission to the building structure. The assembly is to be designed & tested to sustain contract load plus 25% overloads.

The Lift machine shall be placed directly above the hoist way, means of manual operation of the lift car shall be made by providing winding wheel suitably marked to indicate the direction of the movement to enable to lift car to be brought to the nearest landing.

There shall be a safety switch to switch off electrical supply if the manual cranking wheel is engaged before the manual operations.

The gearless machine shall consist of a motor traction sheave and brake drum or brake disc completely aligned on a single shaft. Gearless machine shall be AC gearless with VVVF drive.

2.2 Controller:

The control panel shall have microprocessor based control with operational card file containing logic board with microprocessor chip and erasable programmable chips and take over the commands of elevator for flexibility of Program, better levelling, reduced waiting time, shorter travel time and easy maintenance. This will also indicate detection of stuck hall button, over current protection, motor failure protection.

There will be a provision of segmented displays provided in the logic board, for quick identification of fault and restoration of normal operation. Control panel shall be of 14 SWG CRCA pre-treated in the seven tank process & powder coated.

The control panel shall be compact, incorporate solid state, electronic circuitry for efficient & smooth operations to monitor traffic control. The material used shall be of best quality. The switches, contactors and relays shall be compact and robust in construction and smooth in operation. Controller shall have variable speed arrangement with levelling accuracy of ± 3.00 mm.

TECHNICAL SPECIFICATIONS M&E

The controller shall protect lift motor; automatically apply the brake if any of the safety devices fails to operate including power supply failures at any time. In the event of an earth fault with any door open, the lift shall not work.

No operation of a spring or springs in tension or the completion of another electric circuit shall depend upon to break the circuit to stop the lift at terminal landings.

The interruption of the electrical circuit shall stop and/or shall prevent the movement of the car. Protection shall be provided in the controller to protect the lift equipment against phase reversal, low voltage, over voltage and phase failure. No control system shall be used, which depends on the completion or maintenance of an electrical circuit for the interruption of the power supply and application of the electric-mechanical brakes, when the lift cage reaches the terminal floors.

The controller shall be provided with proper ventilating arrangement so as to avoid overheating and hence malfunction/damage to the controller.

Enclosure shall be made of 1.5 mm CRCA sheet with powder coating with IP 54 Protection class. The enclosure should be provided with proper mounting arrangement. It should withstand vigorous atmospheric conditions.

Controller shall have provision of display to show the status of movement of lift car. Controller enclosure/body shall also have LED array lights with auto/manual switch, for maintenance in bad light, such that it shall neither disturb door closure/opening nor create hindrance while maintenance.

2.3 ANTI-VIBRATION SUPPORTS

The whole traction machine shall be mounted on appropriate anti-vibration supports to minimize noise and vibration.

The lift shall be provided with A.C, variable voltage, variable frequency, microprocessor-controlled motion and drive control system. The bidder shall indicate the model No. name of manufacturer and country of origin being provided, and the cable size required.

2.4 Brakes

The electromagnetic brake or permanent magnet brake shall be spring applied and electrically released. It shall come into action after the lift has come to a complete halt to hold the car in position. The brake shall operate automatically with the safety devices and failure of the mains. It shall be released electrically. It shall be possible to release the brake manually – such release requiring the action of manual force to move the lift in short stops for machine above equipment. In case of machine room less lift, lift contractor shall provide suitable means to hand wind or lower the lift from a remote point.

1. The brake shall be capable of stopping and holding the Lift car in its downward travel to rest with 125% of its rated load from the maximum governor tripping speed. In this condition the retardation of the Car shall not exceed that resulting from the operation of the Safety gear or stopping on the buffer.

2. Springs used to apply the brake shoes shall be in compression and adequately supported.

TECHNICAL SPECIFICATIONS M&E

3. Brake linings shall be of renewable incombustible materials and shall be secured to the brake shoes such that normal wear shall not weaken their fixings. Band brakes shall not be used.
4. No earth fault, short circuit or residual magnetism shall prevent the brake from being applied in the event of loss of power supply to the Lift motor and control circuit.
5. A means of adjusting the brake plunger stroke and releasing the brake in emergency shall be provided.
6. The Lift machine shall be fitted with a manual emergency device capable of having the brake released by hand and requiring a constant effort to keep the brake open.
7. The fail-safe break shall incorporate an approved design of brake switch i.e. pick up, hold, discharge. Brake coil shall be wired in series & their respective switches in parallel. The operation of brake shall be thyristor controlled from solid-state drive-in order to effect minimum pick up time and synchronized start.
8. Dynamic braking system shall be provided by the contractor for all the lifts.

2.5 Governor

Governor shall be placed where it cannot be struck by the lift car or counter – weight in the event of over-run.

Governor for car safety gears shall be adjusted to actuate the safety gear at not less than 115 percent of rated speed and the maximum Governor tripping speed shall be not more than 140% of rated speed. No Governor shall be required to operate the safety gear at less than 45 mm. per minute.

Governor shall be marked with its tripping speed in terms of car speed in meters per minute and shall be provided with suitable casing.

The motor control and brake control circuits shall be opened before or at the time the Governor trips.

Governor ropes shall not be less than 6 mm. in dia. and shall be of traction steel and of suitable construction. The ropes shall run clear of the governor jaws during normal operation of the lift. Governor gears shall have self-lubricating bearings so as not to require frequent attention.

2.6 Ropes

The hoist ropes shall be of traction steel of suitable size, construction and number to ensure proper and smoothest kind of hoisting service and satisfactory wearing qualities.

The ropes shall be non-spinning type having safety factor not less than twelve. The tension in a suspension rope shall be related to the operating conditions as a whole e.g. rope speed, ratio of diameter of pulley, sheave, type of rope groove and intensity of service as well as to its breaking load.

TECHNICAL SPECIFICATIONS M&E

Every lift car or counterweight rope shall be in one length and free from joints. The car and counter weight ends of the suspension rope shall be fastened by spliced return loops, clipped returned loops or individual tapered Babbitt sockets. Loops shall not bear directly on their fixing, but shall be lined with proper thimble eyes or equal protection.

In all cases, the fastening shall be capable of sustaining a load not less than 80 percent of the ultimate strength of the undisturbed rope.

Means shall be provided to equalize the load on the individual suspension ropes. Tensioning devices for compensation ropes, governor ropes and the like shall be protected against damaged due to falling objects. The minimum diameter of ropes for car and counterweight shall be not less than 8 mm. A substantial handhold shall be provided at a convenient height surrounding the guard but clear of the ropes. Suitable degreasing arrangement shall be provided in the machine room.

The suspension ropes shall conform to I.S. 2365/1977/ I.S. 2366/2002 / I.S. 14665:1999-2000 Part-I to Part-5.

Alternative STM (suspension traction media) than specified conventional ropes, if approved by PWD/Lift Inspectorate, shall be accepted.

3. Control Systems.

3.1 VVVF DRIVE UNIT (3VFdrive)

Lift drive controls shall be A.C. Variable Voltage Variable Frequency Drive System with microprocessor based site programmable controls.

In normal operation, the electromagnetic brake shall only be applied when the lift has come to a complete standstill. The brake shall hold the lifts in position at every landing, and shall provide stopping without any jerking effect.

The VVVF Drive shall employ Sine wave PWM control with 12 pulse drive & shall be designed to run at an ambient temperature of 50 Degree Celsius & maximum relative humidity of 90%.

The VVVF drive shall be vector with flow closed loop control always.

Shielded cables to be used to cover the path from inverter output terminal box to motor terminal box; this is required to reduce EMI or radio disturbances.

Input filters to be used at inverter input to reduce disturbance to power supply.

Due to standing wave phenomenon, high voltage spikes get generated at motor terminals operated with VVVF drives. This results into premature burn out / failure of motor winding. To safe guard motor against these voltage spikes, VVVF drive shall consist of appropriate protection device at output of the inverter.

Following protections shall be built in with the inverter: -

TECHNICAL SPECIFICATIONS M&E

- Motor overload / over torque ,Instantaneous over current, Ground fault, Under voltage, Over voltage – 3 Phase, Output & Input phase loss, Output short circuit, Over speed, Spikes & Surges

On fault occurrence, the VVVF drive shall store the status of all parameters prevailing at the time of fault occurrence etc. & the same shall be available to the user to assist him in the fault diagnosis.

3.2 FIRE MAN OPERATION

All building with height more than 15 m shall have fireman's lift. (If required by user for loading cap. of not less than 544 kg/8 person).

The technical parameters define the fireman's lifts. This shall always be in line with the latest IS codes amended up to date even if the below description is found as different from the latest amended IS codes.

3.2.1. Operation Requirement of fireman's lift/s:

The fireman's lift shall be provided with the following as a minimum: - A two position ON/OFF fireman's switch which is common to all lifts in a group control at evacuation floor (normally the main entrance floor) protected in a box with glass in front with suitable label indicating that it is the fireman switch and Audio & visual signal in car

3.2.2. Sequence of operation: Return to Evacuation floor (Phase 1): Shall start when the switch at the evacuation floor is turned to the 'on' position or the signal indicating a fire received from the automatic fire detection and alarm system (if provided by the BMS) is on. The lift(s) controlled by this switch shall cancel car calls and separate from landing calls and no landing or car calls shall be registered. The audio and visual signal in car shall be turned on. All heat and smoke sensitive door re opening devices shall be rendered inoperative. If the lift is travelling towards evacuation floor, it shall continue driving to that floor. If the lift is travelling away from the evacuation floor, it shall reverse its direction at the nearest possible floor without opening its door and return non-stop to the evacuation floor. If the lift is standing at a floor other than the evacuation floor, it shall close the doors & start travelling nonstop to the evacuation floor. When at the evacuation floor, the lift will park with doors open. The audio signal is turned off after this drive.

Fireman's Service: The phase 2 is started after phase 1 if the fireman's switch is on. The lift does not respond to landing calls. All heat and smoke sensitive door re opening devices shall be rendered inoperative. When the car call button is pressed the doors start closing. If the button is released before the doors are fully closed, they reopen. The car call is registered only after the doors are fully closed. After registering a car call the lifts start driving to a call. If more than one car calls are registered, only the nearest call is answered & the remaining car calls will be cancelled at the first stop. At the floors the doors are opened by pushing the door open button. If the button is released before the doors are fully open, they reclose. The lift returns to normal service when it stands at the evacuation floor with door open & the fireman's switch is off or by an electric signal from the automatic fire detection system when it is reset.

3.2.3. The word 'FIRE LIFT' shall be conspicuously displayed in fluorescent color near/on the lift landing doors at each floor.

Requirement for non-fire lifts: For buildings having height more than 15 meters, the non-fire lifts shall be taken out of normal services in the event of fire, by making use of the following provisions given below: - The non-fire lifts shall be provided with a manual two position (ON/OFF) fireman switch acting as a grounding switch on the main floor. The switch shall be common for all lifts in a group control. The switch shall be protected in a box with glass in front with suitable label indicating that it is fire switch. When a signal indicating a fire is received from the automatic fire detection and alarm system or from the grounding switch, the non-fire lifts shall react as follows: - All landing controls and car controls including the door re open button shall be rendered inoperative. All existing registered calls shall be cancelled; and The lift shall follow the automatic command initiated by the received signal in the following way: A lift with automatic power doors when parked at a landing shall close the doors and travel non-stop to the evacuation landing; A lift travelling away from the designated landing shall make a normal stop and reverse its direction at the nearest possible landing without opening the doors and return to the evacuation landing; A lift travelling towards the designated landing shall continue its travel nonstop towards it. A lift in the event of becoming blocked due to the operation of a safety device shall remain immobilized.

Door reversal devices, which may be affected by heat or smoke, shall be rendered inoperative to allow the doors to close. The breakdown or shut down of a lift in a group of interconnected lifts shall not affect the return of the other lifts to the evacuation landing. On arrival at the evacuation landing, lifts shall park there with the car & landing doors open & removed from service.

Note: the doors may close after predetermined time but it shall be possible to open them with landing call button and manually with emergency key.

The lift will automatically be reset to normal operation by: An electrical signal from the automatic fire detection system when it is reset; or the rest of the manual grounding switch.

In case there are fire as well as non-fire lifts in a group control, the common fireman-cum-grounding switch should function as fire switch for fire lifts and as grounding switch for the non-fire lifts.

The fireman's switch shall be located adjacent to the lift opening at the evacuation floor and shall be at a height of approximately 2 m above the floor level.

3.3 Automatic Rescue Device (A.R.D.):

The ARD shall have the following specifications:

- ARD should move the lift to the nearest landing in case of power failure and single phasing during normal operation of lift.
- ARD should monitor the normal power supply in the main controller and shall activate rescue operation within 10 seconds of normal power supply failure. It should bring the lift to the nearest floor at a slower speed than the normal run. While proceeding to the nearest floor the lift will detect the zone and stop. After the lift has stopped, it automatically opens the doors and parks with door open. After the operation is

TECHNICAL SPECIFICATIONS M&E

completed by the ARD the lift is automatically switched over to normal operation as soon as normal power supply resumes.

- In case the normal supply resumes during ARD in operation the lift will continue to run in ARD mode until it reaches the nearest landing and the doors are fully opened. If normal power supply resumes when the lift is at the landing, it will automatically be switched to normal power operation and start from there instead of getting into correction mode and going to lowest floor.
- All the lift safeties shall remain active during the ARD mode of operation □ Audio / Visual alarm to be provided in car to announce ARD operation; voice synthesizer to make an announcement that lift is running to floor level on emergency power and to exit upon arrival.
- The battery capacity should be adequate so as to operate the ARD at least three (03) times without recharging of battery.
- ARD should also operate in case of Single-phase failure.

4 Standard features to be included

4.1 OVER LOAD DEVICE

A load weighing device shall operate when the load in the car exceeds the rated capacity. The operation of the device shall activate buzzer sound and flashing 'overload' signals. At the same time the car doors shall be prevented from closing. When the excess load has been removed from the car, the buzzer alarm shall stop automatically and the car shall function normally. The sensitivity shall be 30 kg for Passenger lifts and 5% of the contract load for service lifts. The load sensing shall be achieved either by way of load sensors placed under car platform or rope/ belt tension device as per manufacturers standard design. The load sensing device should be site- programmable/adjustment type.

4.2 AUTOMATIC SELF-LEVELING

All lifts shall be provided with automatic self-leveling feature that shall bring the lift car level to within ± 5 mm to

+ 10mm for passenger/service lifts and + 10mm for freight lifts of the landing floor regardless of load or direction of travel. The automatic self-leveling feature shall correct for over / under travel.

4.3 ALARM BELL / BUZZER

An Emergency alarm bell/ Buzzer, including wiring to be provided and connected to a properly marked push button in the car operating panel. The alarm bell shall be located at the ground floor, at the floor landing outside and adjacent to hoist way or as desired by PFCL. The alarm sound shall be siren type audible from at least 50 meters from the ground floor landing, operated by Rechargeable Nickel/Cadmium maintenance free batteries to give a warning siren when the alarm button in the car is pressed momentarily.

TECHNICAL SPECIFICATIONS M&E

4.4 ANTI-NUISANCE

If car loading relative to weight in car is not commensurate with number of registered car calls, the system cancels car calls. Systems employing either load weighing or door protective device for activation of this feature are acceptable.

4.5 SAFE LANDING FEATURE

If a car has stopped between floors due to some equipment malfunction, the controller checks the cause, and if it is considered safe to move the car, the car will move to the nearest floor at low speed and the doors will open.

4.6 Door Failure Operation

When an obstruction prevents a door from opening, the controller shall attempt its removal by repeated opening and closing, failing which the car shall travel to the next floor.

4.7 Self - Diagnostic Facility

The Controller shall perform self - diagnostic tests and report the health of the system. The system shall take care of minor faults like door operation and motor overheating. A universal service tool shall be provided in each machine room to assist technicians in quick pin-pointing of mal-function.

4.8 INDEPENDENT SERVICE

Under this operation the car is withdrawn from the group control operation for independent use, such as transporting goods, carrying large number of people between floors or maintenance & at such times only responds to car calls. The lift will remain parked on a floor with its doors open until a floor is selected and the door close button is held until the lift starts to travel. The switch for this service shall be located inside the lockable service box in Car operating panel.

4.9 RETURN OPERATION

Using a key switch on the face plate at main lobby floor, a lift can be taken out of the group control operation & brought to the main lobby floor (or other designated floor). The car will park on that floor with the doors open till independent operations begin.

4.10 CAR CALL CANCELLATION

This function allows passenger to cancel the selection of a floor which is accidentally pressed by pressing the button again.

4.11 DOOR NUDGING

If the Elevator doors are kept open longer than the pre-determined time, an override alarm shall sound and start to close at a slower speed to alert the passenger that the doors must close so that system performance is not adversely affected.

TECHNICAL SPECIFICATIONS M&E

5 CAR ENCLOSURES

5.1 Lift Car

Lift car shall be enclosed on all sides by means of the cage body, gates or doors and such enclosure shall be at least 2.1 meters in height in false ceiling.

The car interior (walls and roof) shall be made of stainless steel 304 sheet of 1.5 mm thick with hairline finish with frame made from MS girders, bracing of adequate size with minimum safety factor of 5, with Toe Guard apron. Hand rail shall be provided inside the lift car. Car door from internal side may have mirror finish panel in combination with other selected panel finish. Suitably designed modern attractive false ceiling with appropriate nos. of energy efficient LED fittings covered with non-accessible glass to avoid contact/theft of LED lights, shall be provided. The lift car shall be fitted with at least one similar Emergency light fitting complete with 2 nos. of cabin type noiseless fans for adequate ventilation. Decision regarding approval of 'Total Car interior design' will be taken by concerned site-engineer in-charge. His decision shall be final and binding upon the lift manufacturer. Minimum car area shall be specified in accordance with the requirements of the B & C Department of the Maharashtra State.

The car shall be provided with an emergency stopping device and an alarm signal, both operated by a push button switch, which shall be clearly marked. The alarm shall be clearly audible in the lift well and nearby passages, in order to obtain assistance in case of break down or failure between the floors.

The car may have stainless steel luminary flush panels and be provided with suitable/rounded corners. The material and/or finish of the car body work shall be durable to withstand frequent washing.

The amplitude of vibration in the car cage shall not exceed 25 microns in running condition and 10 microns in standstill condition.

A solid roof capable of supporting 150 Kg. shall be provided. Roof of car shall be fabricated in painted/powder coated M.S. framework while false ceiling shall be made in relevant selected S.S. finish panel.

The car entrance shall be protected by a centre opening sliding steel door or two speed telescopic S.S. doors as the case may be. Gate/door shall be hung on a steel track by ball bearing hangers and guided on a finished heavy section grooved sill on the car platform.

The car gate/door shall be equipped with an electric motor / suitable mechanical device, which shall prevent the movement of the car unless the gate / door is properly closed.

The enclosure and door including their tracks shall withstand a thrust of 35 Kg. supplied normally at any point excepting vision panel without permanent deformation. The car platform shall be constructed of structural steel shapes securely fastened together and designed on the basis of contact load evenly distributed. The minimum factor of safety shall be 5 for steel. The car frame, which supports the car platform and enclosure, shall be made of structural steel and it shall be equipped with suitable guides and safety devices mounted underneath the car platform.

TECHNICAL SPECIFICATIONS M&E

S.S. chequered plate for flooring shall be of 3 mm thick or as per manufacturers standard. The factor of safety of the component parts and their connections shall not be less than 5 based on the ultimate strength of the materials and the static load imposed on them.

Car operating panel (COP) shall also have 'key switch' to keep the car operation in 'ON' or 'OFF' mode, in addition to normal provision of 'Attendant Key switch' & other necessary buttons. Overload Warning Device (OWD) with Audio-visual alarm, voice announcement system (VAS) In MARATHI, Hindi & English or as per manufacturer's standards with intercom system and telephone instrument in Lift car, near control panel & Ground Floor.

Display / position indicator inside the car, shall preferably be fitted above car doors or at suitable location which shall be easily viewable.

5.2 CABIN FAN

At least One/ two numbers Noiseless pressure fan or blower with Auto ON/OFF shall be provided in each lift cabin with supply grill matching with the interior of the car. Airflow in the car should be such that adequate amount of airflow reaches all parts of cabin. One of the blowers shall be connected thru a rechargeable UPS to ensure continuous blower operation for at least 15 minutes in event of power failure.

5.3 EMERGENCY LIGHTS

In addition to normal lighting an emergency light unit using sealed Nickel/Cadmium Maintenance free battery power pack with charger and fluorescent lamp to operate automatically and to illuminate the car for minimum 30 minutes in case of power failure shall be provided in each lift car.

6. CAR & LANDING DOORS

6.1 Landing Entrances

The entrance on the landings from the hoist way side shall be fitted with automatic, side/center opening two speed telescopic S.S. doors with a clear opening as required at each landing complete with top and bottom tracks, etc.

Car and Door shall be as per fire protection norms of Indian / International standards.

Every landing gate shall be fitted with electrical and mechanical interlocks, which shall comply with the appropriate requirements given below:-

- i) It shall not be possible to open the landing gate from the landing side until the lift car is within that particular landing zone. Provision shall be made for opening the gate in case of emergency by means of special key at terminal floors.
- ii) The lift cannot be started or kept in motion unless all the landing gates are closed and locked. The electrical and mechanical parts of all locking devices shall be of substantial design and construction. The removal of any inspection cover or covers shall not affect the operation of a device. All locking devices shall be fixed securely to the enclosure by suitable means.

TECHNICAL SPECIFICATIONS M&E

iii) Each landing gate should have both electrical & mechanical locking system. After closing the gate electrical contact should not be made unless and until the mechanical locking is done.

The locking device for landing gates shall be so designed that the lock contact shall not be closed until the gate is closed. Any springs used in the locking device shall be in compression and properly supported. Contacts shall be solid type, pivoted or hinged and of sturdy construction.

iv) The design shall be such that reasonable wear between working parts does not permit of interference with the operation of the lift by movement of the lock handles.

v) The conduit / troughing carrying the conductors to the lock shall be securely fixed to the boxes and shall maintain electrical and mechanical continuity.

vi) The levers operating the mechanical parts of the locking device shall be protected from interference from the landing side of the lift enclosure.

vii) The provision to prevent the opening of any landing gate when the car is passing that zone in response to a call from another landing, shall be made for the lift.

6.2 Electric Door Operator for Car Door and Hoist way Doors

Contractor shall furnish and install Electric Door Operators for opening and closing the car door and the hoist way door. The equipment shall consist of a machine on the elevator car, operating the car door when the car is stopping at a landing. The car door and hoist way door shall be mechanically connected and shall move simultaneously in opening and closing.

The car door and the hoist way door shall be power opened and power closed and shall be checked in opening and closing with an oil cushioning mechanism built into the gear unit.

Each hoist way door shall be provided with an inter-lock, which shall prevent movement of the car away from the landing until the doors are locked in the closed position and should meet relevant IS codes.

An electric contact for the car door shall be provided which shall prevent car movement away from landing unless the door is in the closed position as defined in the ISI Codes.

Necessary switches shall be provided in the elevator machine room to control the operation of the doors.

The car door and the hoist way door shall open automatically when the car stops at a landing. The closing of the car door and the hoist way door must occur before the car can be started. Doors can be stopped and reversed during their closing motion, as soon as infrared curtain beam provided on either side of door is cut/activated, the door shall automatically close after predetermined time interval.

Contractor shall furnish and install for the car and each landing sliding door, sheave type two point suspension hangers complete with tracks, Sheaves and rollers shall be of steel and shall include shielded ball bearing to retain grease lubrication. Adjustable ball bearings rollers shall be provided to take the upward thrust of the doors.

TECHNICAL SPECIFICATIONS M&E

Tracks shall be of suitable steel section with smooth surface, landing gates/doors including hangers and tracks shall withstand a thrust of 35 Kgs. applied normally at any point except vision panel without causing any damages. S.S.304 grade panels used for car and landing doors shall be of 18 SWG.

7 CAR SIGNALS & OPERATION DEVICES

7.1 Indicators and Signaling System:

Signaling system shall be of all bell type and the lift should be provided with –

- A. Manual reset light annunciator mounted flush in the car and connected to one heavily insulated type of call buttons at all landings including all wiring, bell transformers etc. The car annunciator box shall contain a single/double row of light indicators numbered to correspond to the various landings.
- B. Luminous UP/DOWN indicators incorporated in push button face plates shall be provided at all landings.
- C. Illuminating type hall position indicator on all landing to indicate the position of the car on the hoist way.
- D. Illuminating type & audio announcement of car position indicator in the car.
- E. The signaling system shall work on main supply and during ARD operation as well.
- F. The wiring for the same shall be independent of the lift wiring.
- G. Display at all floors and in car.
- H. LED or as per manufacturers standard display at Ground Floor.
- I. LED or as per manufacturers standard display inside the Car at suitable height.
- J. Infrared safety throughout the door height is preferable.
- K. Automatic Rescue Device.
- L. Alarm bell shall be operated on D.C. battery.
- M. Firemen switch on ground floor as per fire protection rules.
- N. Over load indicator - The lift shall be equipped with a system of over passenger over load Safety. In case the persons or load exceeds the rated capacity of elevator, it will not start at all. The system shall be with audio and visual indication.
- O. Floor-Numbers on the Car Operating Panel & Landing Operating Panel should also be Present in "Braille" character / font of sufficiently large dimensions, suitable for differently abled.
- P. Hot-line communication between lift car and control center shall be provided along with necessary instruments, in case of lift breakdown.
- Q. Chime / gong producing sufficiently loud audio signal along with visual light signal shall be provided at each landing when lift reaches any of the landing position, to indicate lift arrival at that landing.

TECHNICAL SPECIFICATIONS M&E

R. The written visual indication of overload capacity at each landing in each car shall be displayed.

7.2 Infrared Light Curtain

The lift doors shall be provided with a safety device in the form of infra red light curtains. This shall prevent the lift doors from closing, in case of any obstruction. This infrared light curtain should have no effect of ambient light on its operation. Any faulty beam should be detected and fault indicators should turn on to inform the operator about the fault status.

This light curtain should be housed / embedded in a mechanical safety edge to give double protection on door detection. In case of failure of infrared light curtain, this conventional mechanical edge safety should extend protection to humans while entering the lift.

8 LIFT SHAFT & PIT

8.1 Guides

Car guides and counterweight guides shall be as per manufacturer's standard, guides shall be continuous throughout the entire length and shall be provided with adequate iron or steel brackets or equivalent fixing.

It will be designed and spaced in such way that the guides shall not be deflected more than 5mm under normal operation. Guide brackets and shims, if any, shall be of steel and shall not be directly supported and fastened to the lift well enclosure walls unless such wall is of such construction and strengthened as to adequately withstand the thrust imposed on the guides under all conditions of the lift service. The fastenings shall be built in the walls by means of bond blocks or expansion bolts or through bolts with metal plates of such thickness and size as to adequately distribute the load on the wall.

Guides shall be arranged to withstand the action of the safety gear when stopping a counter weight or fully loaded car. Guides shall be of such length that it shall not be possible for any of the car or counterweight shoes to run off the guides.

Regular greasing and lubrication is to be done as required. Oil shall be distributed evenly to the guide rails and the rate of feed shall be adjustable.

8.2 Buffers

Spring type buffers shall be fitted below the lift cage. Buffers shall be placed symmetrically with respect to the center of gravity of the lift cage within a tolerance of 5 cm. and shall be so arranged that the lift cage in ordinary circumstances of the operation, cannot strike them.

Counter weight shall be fitted with buffers, similar to those specified for lift cage and arranged symmetrically below the weight.

Buffers in the pit shall be mounted on the steel channel/concrete blocks, which extend between both car and counter weight guide rails provided by the contractor.

TECHNICAL SPECIFICATIONS M&E

For speed less than or equal to 1.5 mps, suitable heavy-duty spring buffers shall be placed below the car and counter weight but in the pit & arranged to sustain any shock, should the lift over travel past the terminal limits. Buffers shall be mounted on RCC foundation blocks. Dowels for the purpose shall be left while casting the pit floor alternatively floor reinforcement could be exposed by chipping for welding additional reinforcement for dowels. Clearance from underside of the car resting on a fully compressed buffer shall not be less than 1.20 mtr. Buffers shall be designed for a design speed + 15%. Oil buffers shall be provided for the passenger lifts for speed of more than 1.5 mps and for Machine room less lifts for all speeds. The normal operation of the lift shall depend on the return of the buffers to their normal extended position after operation. The device for checking this shall be an electric safety device mounted on the buffers.

8.3 Counter Weight

Frame type counter weights made of cast iron shall be employed. The sections being secured by rods passing through holes in all sections, having locknuts at each end, further secured by solid pins. Factor of safety of the threaded portion of the rods shall be not less than ten.

The traction shall be such that no appreciable slip shall occur under normal conditions but that slip shall be free to take place up to the landing of either the car or the counter weight.

The guide shoes of counterweight shall be fixed and adjusted so that play in the direction of the width of the counterweight does not exceed five mm.

Adjustable guide shoes on counterweight shall be so designed that their correct adjustment shall be maintained independent of the tightness of bolts or set screws through slotted holes. Rod type counterweight shall be slotted for use with the steel guides in which case separate guide shoes need not be fitted.

The counterweight shall be equal to the weight of the complete car and approximately 40% of the contact load. The operation shall be smooth and economical.

A substantial metal counterweight guard with steel frame work of required length shall be provided at the bottom of hoist way.

Alternative arrangement for holding the counterweights in steel frame, if any, as approved by PWD/Lift Inspectorate, shall be accepted.

9 SAFETY DEVICES

9.1 Emergency Safety Devices

The lift shall be provided with one or more car safety devices, attached to the lift car frame and preferably placed beneath the car. The safety devices shall be capable of stopping and sustaining the lift car with rated load in the car.

The safety gears to be used shall be of the following types:

- a) Instantaneous type limited to speed not exceeding 60 Mtrs./min.
- b) Gradual wedge clamp (GWC) type with gradual increasing retarding force.
- c) Flexible guide clamp (FGC) type with constant retarding force.

TECHNICAL SPECIFICATIONS M&E

The lift shall be equipped with an over speed governor device, which shall operate to apply the safety gear in the event of the speed of the lift car in the descending direction exceeding a predetermined limit.

The operation of the safety devices shall not cause the lift car platform to become out of level in excess of 3 cm. per meter measured in any direction.

When the safety gear comes into operation, it shall automatically open the operating circuit but it shall be possible for a responsible person to release the safety gear after a thorough inspection of the equipment and taking of any necessary precaution by reversing the direction of the motion of the machine.

The safety device shall be such that it can be released as soon as the lift car is raised.

The safety gear shall operate to stop and sustain the lift car in the event of failure of the suspension ropes or in the event of the lift exceeding a predetermined maximum speed in the descending direction.

Every safety gear shall operate positively and mechanically independent of any springs/used in its construction. Keys of good quality shall key any levers or dogs operated by shafts to such shafts.

The design of the safety gear shall provide for its application to both guides and to each side of such guides substantially equal. Any additional rope used solely for the purpose of operating the safety gear shall be laid over independent pulleys, running on independent shafts.

All bearings for drums and shafts in connection with the safety gears shall be of non-ferrous metals.

No safety gear shall depend on the completion or maintenance of an electric circuit for its operation. All safety gears shall be applied mechanically.

The gripping surfaces of the car or counter weight safety gears shall not be used to guide the lift cage or counter weight but shall run free of the guides during normal operation of the lift (A rail or ratchet shall not be held to constitute a sufficient safety for lift traveling in a vertical or substantially vertical direction).

88) 9.2 Limit Switches

Lift shall be provided with upper and lower normal terminal limit switches to stop the car automatically within the limit of top of car clearance and bottom run (by over travel) from any speed attained in normal operation. Such limit switches shall not be independent of the operating device, ultimate or final limit switches and the buffers.

Normal terminal limit switches shall be fitted in the lift car or in the lift well or in the motor room and such switches shall be brought into operation by the movement of the lift car. The switch and the spring buffers shall be so arranged that the switch shall open before the buffers and engaged.

Ultimate or final limit switches shall not be mounted on the lift cage and shall be operated by the movement of the lift car in the lift well within the limits of normal travel.

TECHNICAL SPECIFICATIONS M&E

Ultimate or final limit switches shall not control the same switches on the controller as those are controlled by the terminal limit switches unless two or more separate and independent switches are provided, two of which shall be closed to complete the motor and brake circuit in each direction of travel, when the ultimate or final limit switches control the same switch or switches on the controller as the operating device or the terminal limit switches, they shall be connected in the control circuit on the opposite side of the line.

Ultimate limit switches designed to open the main circuit of the motor may control the same switch or switches on the controller as those controlled by the terminal limit switches but when such ultimate limit switches are employed on direct current power supplies they shall be provided with additional contacts to control the brake circuits.

All ultimate or final limit switches shall be of enclosed type and shall be mounted properly. The movement of the lift car shall open the contact of all such switches positively and mechanically.

9.3 Pit Flood Switch

Elevator Pit Flood Switch Features:

- 1) Stainless Steel adjustable float switch
- 2) Normally Open contact rating: 220VAC - 2.5A - 50W
- 3) 3/8 throw to activate
- 3) Electrical knockouts for 1/2 liquid tight fittings The PFS Elevator Pit Flood Switch is mounted a few inches from the bottom of the elevator pit and will activate when it comes in contact with water. The float of the switch will rise when it contacts rising water, and when it is raised 3/8, a normally open contact will close.

Please note that Vator Accessories is providing the float switch and enclosure only. The switch will need to be wired to the controller by a trained technician. The controller will require the logic to follow the recommended operation below:

Recommended Operation

1. PFS detects rising water in pit
2. PFS normally open contact closes
3. The controller receives the closed contact signal
4. The elevator automatically travels to the uppermost floor, doors open and remain open
5. The elevator remains at the upper floor with the doors open until it is reset by a qualified Elevator Mechanic or Elevator Inspector

10 OPERATION AND WIRING

10.1 Operation:

Operation of lift shall conform to the following requirements:

10.1.1) It shall not be possible to start the lift car under normal operation unless every landing gate is in the closed position.

10.1.2) The landing push buttons shall be operative during the whole time when an occupied lift car is in use. The landing push buttons shall register the call but the lift remains inoperative until the person or persons, using the lift have vacated the lift car and the landing

TECHNICAL SPECIFICATIONS M&E

gate has been closed. An emergency stop switch shall also be fitted on the top of the lift car for use of persons working thereon.

10.1.3) Momentary pressure of a car button shall send the car to the landing selected where the car shall automatically stop. After a car button is pressed, uninterrupted use of the car shall be ensured until the desired landing is reached and the car gate is opened and closed.

10.1.4) Momentary pressure of a landing button shall bring the car to that landing unless the car is already in use.

10.1.5) Every precaution shall be taken to ensure quiet operation of lift doors and machinery. The installation of the lift machine and any motor generator set shall prevent most of the noise by providing rubber cushions.

10.1.6) The lifts in the scope of work, shall operate on full collective selective with ON/OFF switch.

10.2 Electrical Wiring:

10.2.1) All electric supply lines and apparatus in connection with the lift installation shall be so constructed and shall be so installed, protected, worked and maintained that there may be no danger to persons there from.

All metal casing of metal coverings containing or protecting any electric supply or appurtenances shall be effectively earthed.

Suitable Caution Notice shall be affixed near every motor or other apparatus in which energy is used at a pressure exceeding 250 Volts.

The copper armoured cables shall be fixed on wall / ceiling from Switchgear at Meter room through the lift well to switchgear at distribution position in designated place.

10.2.2) The Tenderer shall lay the electric cable from meter room to Lift machine room, complete with earthing wires and provide switchgears etc. In no case the work of Erection, Testing and Commissioning shall be held up for want of electric supply from Corporation.

10.2.3) For the purpose of fabrication, erection and testing etc. to complete the job, tenderer shall use available supply on the site and shall pay charges of Rs.2000/- per Lift.

10.2.4) On carrying out complete wiring work, tenderer shall arrange to submit test report to Electric Supply authorities and get the meter connected and kept the lift ready for Testing and inspection of P.W.D. Inspector.

Please refer complete details of electrical wiring works in the respective specifications onwards.

10.3 Connectivity to Building Management Services (BMS)

The Contractor shall provide potential-free connectivity and communication ports for all elevators to Building Management System.

10.4 Data Storage and Retrieval

Data from daily operations shall be stored in the control system and shall be retrievable. Data shall include all particulars of calls, mode of operation, door open/close, acceleration /

TECHNICAL SPECIFICATIONS M&E

deceleration, stops, status etc. The contractor shall specify in his offer the full capability of his system in this regard. It should be possible from such retrieved data to prepare an updated traffic analysis at any time.

10.5 Fire Alarm Home Landing (Through BMS)

The contractor shall provide only potential free contacts and communication ports for fire alarm home landing through BMS.

11 Electrical Work

The electrical work shall be carried out as per General & Technical Specifications specified in Unified SOR 2018, using FIRST CATEGORY material approved in unified schedule 2018 with FRLS cable

11.1 The electrical work comprises of following works (Applicable to all lifts)

One 5A - 5 pin socket with switch in GI enclosure of suitable size and one light point with switch & 28W LED light, shall be provided in lift pit and at each landing in lift shaft, complete with wiring in approved manner.

A set complete with one 23/28 W LED light of approved make, 3 meter long PVC 3 core flexible cord terminated in 3 pin plug, shall also be supplied for each lift, for maintenance staff.

All the lights and outlet points shall be connected to a separate circuit independent of lift mains and control wiring.

Lift contractor shall carry out the necessary wiring in the conduit / troughing / cabling/casing - capping from the lighting D.B. in lift machine room.

11.2 Switch gears at Service & distribution position

(a) 63 Amp 440 V TPN with metal enclosure with fuse (one at service and one in each Machine room for every proposed lift at distribution position for all the proposed lifts.) – 2 Nos. for each lift.

(b) 32 Amp, 250 V, MCB (one at service and one in each Machine room for every proposed lift at distribution position). – 2 Nos. for each lift.

(c) 32 Amp DPMCB and 3 way 6 Amp SPMCB per way = 1 No each at distribution position in Machine room lighting for each lift – 1 No. for each lift.

11.3 E.L.C.Bs.

A. 32/40 Amp 2 Pole E.L.C.B. Type B and complete with interconnection and wiring, M.S. enclosure = 1 No. for each lift.

B. 63 Amp & 4 Pole E.L.C.B. Type B and complete with interconnection and wiring, M.S. enclosure = 1 No. for each lift.

11.4 M.S. Angle / Flat bar frame work (As per manufacturer's Standard)

Switchgear at service (in Meter room) and at distribution position (in Machine room) shall be fixed by using:-

TECHNICAL SPECIFICATIONS M&E

i) 40 x 40 x 5 mm of M.S. Angle

ii) Flat bar: 40 mm x 5 mm thick.

11.5 Cable

The contractor shall provide 1.1 KV grade stranded Cu conductor, XLPE insulated, extruded PVC inner and FRLS outer sheathed, galvanized steel round or strip armoured cables for Power supply cable and lighting cable from service point to machine room for the lift, through lift shaft, lift shaft wiring and machine room wiring with switchgears, fittings and fixtures. The copper armoured cables shall be fixed on wall / ceiling from Switchgear at Meter room through the lift well to switchgear at distribution position in Machine room of followings: –

a) Power Cable - 4 Core x 6 SQ MM.

b) Lighting Cable – 2 Core x 2.5 sq.mm. Copper

2A.27.1 - Cable end terminations

Providing cable end terminations at incoming and outgoing end of copper armoured power and lighting cables-

a) 4 Core x 6 SQ MM .

b) 2 Core x 2.5 sq.mm.

(Note- old cable removed from site is to be hand over to concern MCGM department.)

11.6 Point Wiring

a) Providing lighting wiring using copper cable of 2 core x 2.5 Sq.mm 1100 V grade with proper saddle support at 1 feet along the run of cable in lift pit and lift well for inspection and maintenance purpose. One ordinary lamp point and plug point of 5/6 Amp with S.P. Switch at lift pit and lift shaft top and midway shall be provided as per requirement

b) Point wiring in Casing-N-Caping with 1.5 Sq. mm copper conductor, 1100 V grade shall be provided in lift each Machine room for 1 no. of exhaust fan, The exhaust fans shall be enclosed in safety covers/wire mesh.

11.7 Fittings & Fixtures

Following fittings and fixtures shall be provided: –

i.) Ordinary lamp points at each floor in lift well and in lift pit with 18/23/28 Watt LED light as per point wiring provided at lift well, for every lift well.

ii.) One no. of bulkhead fitting outside every lift Machine room with point wiring.

iii.) One no. of Exhaust fan 380 mm sweep, 900 RPM, Single ph., 2350 CFM shall be provided for each lift Machine room as per point wiring in each lift Machine room.

11.8 Meter Leads

Providing 3 single core cu wires of 25 Sq.mm. sizes for phases and 1 single core wire of 10 Sq.mm for Neutral for 63 Amp TPN switch & 6 sq. mm cu wire for 32 A MCB, lead through PVC flexible pipe with proper fixing arrangement.

TECHNICAL SPECIFICATIONS M&E

11.9 Earthing

a) The terminal for the earthing of the frame of the motor, the winding machine, the frame of the control panel, the cases and covers of the tappet switch and similar electric appliances, which normally carry the main voltage shall be as per IS 732-1958 Indian Electricity Rules 1956 & Electric Supply Co.'s Regulations as applicable.

The terminal for the earthing of metallic cases and covers of doors, interlocks, call and control switches, stop buttons, car switches, limit switches, junction boxes and similar electrical fittings which normally carry only the control current shall be at least equivalent to 5mm brass screw, such terminal being one specially provided for this purpose and the earth conductor shall be at least equivalent to 7/29 in copper conductor.

The Earthing conductor shall be secured to the Earthing terminal in accordance with the recommendations made in clause 7 of IS - 732 and also in conformity with Indian Electricity Rules 1956 as applicable.

The exposed metal parts of electrical apparatus installed in a lift car shall be earthed through wire ropes or ramp supporting in car, but shall not be earthed by means of an earthing conductor in the trailing flexible cable. One side of the secondary wiring of the bell transformers and their cases shall be earthed.

b) Separate Earthing conforming to IS-3043 shall be provided at service for the lift and earth continuity conductors shall be provided as follows:-

i) Earthing station / plate of size 600 mm x 600mm x 3.15 mm tinned copper shall be connected with 2 nos. of tinned copper flat bars of size 25 x 3 mm up to earth chamber. These copper flat bars are to be connected to tinned copper. test link of size 32 mm x 6mm .

ii) Earthing from test link to hoist machine, its support assembly & switchgear shall be done with 2 nos. of 10 SWG copper conductors terminated by lugs with double earthing as per requirement.

Note:-all electrical work shall be carried out as per Unified SOR 2022 and Technical specifications.

12 Civil Work

The scope of civil work consists of following works:-

- i.) Brick masonry wall works for & around landing doors, chipping of walls, door openings, fascia plates architraves, making holes in the walls / slab. Necessary civil work in all respect in lift shaft & lift pit required for foundation with white glazed tiles on the wall., complete with final finishing plaster, white wash. Making lift openings as per required size for landing doors.

TECHNICAL SPECIFICATIONS M&E

- ii.) Tenderer shall examine the maximum bending moment of the beam & structural stability of lift shaft / structure, Lift machine platform etc. and suggest the strengthening if required with detailed working.
- iii.) A Firm, stable and sturdy scaffolding shall be erected in the hoist way for carrying out the lift work.
- iv.) Barriers should be provided across all open entrances to avoid chance of accident.

The necessary civil work which is not included in the specifications but required for commencement of lift in all respect, should be carried out by the Tenderer without any additional financial implications.

13 Testing

Various tests and thorough inspection shall be carried out during manufacturing of the lift components to ensure that they comply with the standard practice. The following tests shall be carried out after lift installation and before it is put into normal service.

The lift manufacturer shall provide the necessary test weights and instruments without any extra cost

1. Tests to determine the insulation resistance.
2. Tests to determine that earthing of all the conduit switch casings and similar metal work
3. is continuous.
4. Tests to determine that the motor (including no load test), brake, control equipment and
5. door locking devices function correctly.
6. Tests to determine that the lift car shall raise and lower at rated load.
7. Test to determine that the lift car shall attain rated speed.
8. Tests to determine that the safety gear shall stop the lift car with rated load.
9. The runway test shall be carried out with all electrical apparatus operative except for the over speed contact or cutout on the governor. For the lifts operating directly from alternating current, the governor shall be tripped by hand at the maximum speed obtainable.
10. Testing the ARD device operation on power failure & overload audio-visual warning indicator.
11. Operations of emergency brake device.
12. All safety features shall be tested.

14 POST INSTALLATION TESTS AT SITE

Post installation test at site shall be conducted by the lift contractor in the presence of PFCL / Consultant as per IS 14665 PART 3 and PART 5 and the below is not an inclusive list. Also

TECHNICAL SPECIFICATIONS M&E

the contractor will have to perform tests to confirm the performance parameters in the presence of PFCL and its representatives post installation and commissioning.

The tools & tackles required for such tests will have to be brought in by the lift contractor. All test instruments shall be calibrated not more than one year prior to their use. The contractor may be asked to submit calibration certificates or other documents for proof of compliance.

14.1 Levelling Test

Accuracy of the floor leveling shall be tested with the lift empty, fully loaded.

The lift shall be run to each floor while travelling both in upward and downward directions and the actual distance of car floor above/ below landing floor shall be measured. In each case there shall not be any appreciable difference in these measurements for leveling at the floors when the car is empty and when it is fully loaded. The tolerances for leveling shall be as ± 5 mm accuracy.

14.2 Safety Gear Test

Instantaneous safety gear controlled by a governor should be tested with contract load and a contract speed, governor being operated by hand. Two tests should be made, however, with wedge clamps or flexible clamp safeties, one with contract load in the car and the other with 68 kg (equivalent to one person) in the car. The stopping distance obtained should be compared with specified figures and the guides, car platform, and safety gear should be carefully examined afterwards for signs of permanent distortion.

Counterweight safety gear should be tripped by the counterweight governor and the stopping distance noted. In this case, however the governor tripping speed should exceed that of the car safety governor but by not more than 10 percent.

During the safety gear test, car speed (from the governor or the main sheave) should be determined at the instant or tripping speed with that stated in I.S. The governor jaws and rope should be examined for any undue wear.

14.3 Contract Speed

This should be measured with contract load in the car, with half load with no load, and should not vary from the contract speed by more than 10 percent. The convenient method is by counting the number of revolutions, made by the sheave or drum in a known time. Chalk mark on the sheave or drum and a stop switch will facilitate timing but care must be exercised to ensure that no acceleration or retardation periods are included. If the roping is 2 to 1 the sheave speed is twice the car speed. Alternatively, the speed can be measured by a tachometer applied directly to shaft or a contact free tachometer immediately below the sheave.

14.4 Lift Balance

After the above test, some of the weight shall be removed until the remaining weights represent the figures specified by the bidder. With this condition car at half way travel the effort required to move the lift car in either direction with the help of winding wheel shall be as nearly as can be judge by the same.

TECHNICAL SPECIFICATIONS M&E

14.5 Car and landing doors interlock

The lift shall not move with any door open. The car door relay contact and the retiring release cam must be tested. The working of the door operation and the safety edges and light equipment if any provided shall also be examined.

14.6 Controllers

The operation of the contactors and interlocks shall be examined and it shall be ascertained whether all requirements lay down in the specifications have been met.

14.7 Normal Terminal Stopping Switches

This shall be tested by letting the car run to each terminal landing in turn, first with no load and then with contract load and by taking measurements, top and bottom over travels can be ascertained.

14.8 Final Terminal Stopping Switches

The normal terminal stopping switches shall be disconnected for this test. It shall be ensured that these switches operate before the buffers are engaged.

14.9 Insulation Resistance

This shall be measured (after removing the electronic PCB's and their connection) between power and control lines and earth and shall not be less than 5 mega-ohms when measured with D.C. voltage of 500 volts. Test certificates thus conducted in the controlled factory environment shall be submitted.

14.10 Earthing

All conduits, switches, casing and similar metal work shall have earthing continuity.

14.11 Ropes

The size, number construction and fastenings of the ropes should be carefully examined and recorded.

14.12 Buffers

The car should be run on to its buffers at contract speed and with contract load in the car to test whether there is any permanent distortion of the car or buffers. The counterweight buffers should be tested similarly.

15 Tools

The Tenderer shall provide required branded tools for user department for ordinary maintenance work along with tool box.

Tool box shall contain normal plier, nose plier, 12" screw driver, continuity tester, required ring & fixed spanners, adjustable spanner, cable / wire stripper etc. each for each machine room.

16 STEEL MATERIALS

This specification comprises of supply, installation, testing and commissioning of steel material / structure / items required to provide for the lift, like sill support angles,

TECHNICAL SPECIFICATIONS M&E

facia plates, hitch plates, M.S. Pit ladder, M.S. trap door cover with frame, supporting beams in the lift machine room, R.S. Joist / beam / channel, S.S. chequered plate platform and other allied work in the lift shaft and lift pit.

The structural steel framework in the lift shaft for supporting the lift machine shall be provided. If necessary, M.S. Grill partition for lift machinery for safety purpose shall be provided. Complete M.S. structure shall be tested for its mechanical stability.

The cost of all steel material required for lift installation shall be inclusive in the offer.

17 ARCHITRAVES / FACIAS ON EACH LANDING

Each landing shall be covered with architraves / fascias on all the floors to have aesthetically good appearance. Architraves / fascias shall be provided on all the floors in such manner that lift car gate clearance may not reduce and no disturbance will be caused for opening of car gate. The contractor shall provide Architraves / fascias for opening of car gate on all the floors. Top, Bottom and side wall of opening of car gate at each floor shall be covered with architraves / fascias and front side of opening of car gate at every floor shall be covered with architraves / fascias of 150 mm size by width and the cost is included in the SITC of Lifts. If any additional Architraves / fascias work is to be carried out as per the site requirement. The work shall be carried out as per SOR Activity R2-CS-FL-28-L.

18 TRAILING CABLE

Trailing cables exceeding 30 meters in length shall run so that the strain on individual cable conductors will be reduced to a minimum and the cables are free from contact with the car counterweight, shaft walls or other equipment. Trailing cables exceeding 30 meters in length shall have steel supporting fillers and shall be suspended directly by them without rubbing over other supports.

19. PROVISIONS FOR THE DISABLED AND HANDICAPPED

All the Passenger Lift shall be provided with following features:

- Lift control buttons at locations and height specified in IS 15330 - 2003
- Hall call buttons at locations and height specified in IS 15330 – 2003
- Hand rails shall be provided on the side walls of the Lift at height & locations specified in IS:15330 - 2003. An international symbol of access of the disabled shall be permanently and conspicuously displayed at each and every Lift landing next to the Lift entrance (to be provided by signage contractor). Braille notations indicating the floor levels shall be incorporated in each button or next to each button at the COP and hall call buttons.
- A digital voice system for announcing the car position, opening/closing of doors, direction of travel and messages shall be provided as per IS:15330 - 2003
- A laminated safety glass type mirror of at least half of the size shall be installed on rear panel at appropriate position as per IS: 15330 – 2003
- ASSOCIATED CIVIL WORKS

TECHNICAL SPECIFICATIONS M&E

- The scope of civil work consists of following works:-
- i) Brick masonry wall works for & around landing doors, chipping of walls, door openings, fascia plates architraves, making holes in the walls / slab. Necessary civil work in all respect in lift shaft & lift pit required for foundation with white glazed tiles on the wall , complete with final finishing plaster, white wash. Making lift openings as per required size for landing doors.
- ii) Tenderer shall examine the maximum bending moment of the beam & structural stability of lift shaft / structure, Lift machine platform etc. and suggest the strengthening if required with detailed working.
- iii) A Firm, stable and sturdy scaffolding shall be erected in the hoist way for carrying out the lift work.
- iv) Barriers should be provided across all open entrances to avoid chance of accident.
- The necessary civil work which is not included in the specifications but required for commencement of lift in all respect, should be carried out by the Tenderer without any additional financial implications.
- **NOTE:-**
- **The details given above are tentative, bidders are requested to visit the site and collect actual details and quote as per actual requirement at site.**

APPROVED MAKE LIST:

Sr. No.	Approved make
1	M/s. OTIS Elevator
2	M/s. Kone Elevator
3	M/s. Schindler
4	M/s. Johnson lift
5	M/s. Escon Elevator
6	M/s Eros Elevators
7	M/s Thyssen Krupp Elevators
8	M/s. Eskay Eevators
9	M/s. Trio Elevators

TECHNICAL SPECIFICATIONS M&E

10	M/s. Omega Elevators
----	----------------------

APPLICABLE STANDARDS

Unless otherwise specified elsewhere in this specification, the rating Performance and testing of equipment and accessories shall conform to the latest revisions of standards listed below. Bidder can obtain copies of Indian Standards Specifications from Bureau of Indian Standards, Manek Bhavan, Bahadur Shah Zafar Marg, New Delhi-110002 on payment of applicable charges.

Standard	Title
IS:962:1989	Code of Practice for architectural and building drawings (second revision)
IS:4591:1968	Code of Practice for installation and maintenance of escalators.
IS:14665	Specification for electric traction lifts.
(Part 1):2000	Guidelines for outline dimensions of passenger, goods, service and hospital lifts.
(Part 2 / sec 1 & 2) : 2000	Code of Practice for installation, Operation and maintenance, section 1 passenger and goods lift, section 2 service lifts.
(part 3 / sec 1 & 2):2000	Safety roles, Section 1 passenger and goods lift, section 2 service lifts.
(part 4 / sec 1 & 9):2001	Components, Section 1 Lift buffers, Section 2 Lift guide rails and guide shoes, Section 3 Lift car frame, car, counterweight and suspension, Section 4 Lift safety rears and governors, Section 5 Lift retiring cam, Section 6 Lift doors and locking devices and contacts, Section 7 Lift machines and brakes, Section 8 Lift wire ropes, Section 9 Controller and operating

TECHNICAL SPECIFICATIONS M&E

	devices.
(part 5):1999	Inspection Manual.
IS: 325	3 Phase Induction motor.
IS: 4064 (Part – II) 1978	Specific requirements for the direct switching of individual motors
IS: 4047	Switch fuse unit
IS: 9224 (Part-II)- 1979	HRC Cartridge Fuse links up to 650 volts.
IS: 1255	Cable laying
IS: 694 – 1977	PVC insulated electric cables for working voltage up to and including 1100 volts.
IS: 3043	Earthing
IS: 900	Installation of Motors & Starters
IS: 1231	Motor frame size
IS: 4064	Switches
Electricity Act 1910	Indian Electricity Rules
IS: 732(Part – III) – 1982	Code of practice for Electrical Wiring installations
Rule 41, 51, 54 & 61	Local fire insurance association code for insurance.

TECHNICAL SPECIFICATIONS M&E

IS 2365/1977/ IS:2366/2002 IS:14665:1999-2000 Part I to Part-5	Suspension Rope.

SPECIFICATIONS FOR COMPREHENSIVE ANNUAL SERVICING & MAINTENANCE CONTRACT FOR LIFTS AFTER COMPLETION OF 3 YEARS DEFECT LIABILITY PERIOD

PREAMBLE:

It will be sole responsibility of the contractor to keep the Lift in safe working condition at all the time as per relevant Standards, Rules and Regulations in force. The contractor should be holder of License from the Lift inspector and permission from the appropriate authorities to service and maintain adequate number of lifts.

The contractor shall use the services of trained, appropriately skilled personnel who shall be directly employed and appointed by the contractors. They shall be qualified and experienced to keep the entire Lift and its equipments in proper working condition. They will also take all reasonable care to maintain the equipments properly adjusted and they will take all reasonable care to maintain the Lifts in efficient, reliable, neat, tidy and safe operational condition so as to meet all the P.W.D.'s / Lift Inspectors requirements.

The contractors shall give service and maintenance program every month in advance. The contractor shall direct their said personnel as per scheduled program given and approved by user department to the above said Lifts once in a month during working hours to examine, lubricate and adjust the equipments of the Lifts in presence of either Municipal Engineer or concerned person of user department. They shall obtain from them, signature on the servicing/maintenance documents with Names, Designation etc. on the letter head of the contractors for each monthly servicing repair and maintenance and produce the same in every quarter along with bills.

The contractor shall check , adjust, clean and lubricate all the items mentioned below and enter into logbook duly signed, at least once a month.

Abrasion in main Diverter sheaves.

Wear and Tear in Main Ropes.

Break setting and leveling.

Normal operations of all gates.

Gate Lock inter- locking of all gates.

TECHNICAL SPECIFICATIONS M&E

Guide shoes, gate lock ram checking.

Three phase safety tipping

Over speed governor checking

Buttons, Signal checking of all floors.

Condition of cable wiring etc.

All contacts, circuits, relay should be checked for physical condition and their settings.

Condition of motor, driver and all major equipment with proper oiling and greasing of the same.

Machine, thrust bearings, bushings worm shaft and wheel.

Lift motor, motor generator, motor windings, rotating element, commutator and bearings.

Controller, P.C.B. Drives, transducer, resistors, condenser, power amplifier, transformers, Coils, contacts, leads, tinning device, dash pots etc.

Governor, Governor sheave, shaft assembly, bearings, contacts and Governor jaw.

Car and all landing gates, hoist way door, inter locks, door hangers, door contacts, and auto Doors safety shoes, deflector or secondary shoes.

Guide rails, car & counter-weight and their guide shoes, buffer springs.

Break safety system, break contact lining and components.

Clean the lift well properly.

Clean the cabin cage from inside and outside, the fan, the Lift pit etc. properly.

Car and hall buttons, position indicators, hall lanterns, direction indicators, landing signals fixtures, top and bottom safety switches etc.

Examine the ropes and their attachments, safety devices, door locks, worms and gears, all moving parts etc. and functioning of over load indication devices.

If the Lift motor is found burnt during normal use, the same shall be replaced / repaired immediately at the cost of contractor. The contractor shall replace all the spare parts free of cost immediately for normal wear and tear whenever necessary. The yearly cost of the service and maintenance shall be inclusive of the above. In case the above becomes necessary due to reasons beyond the control of the contractors, Rewinding / Replacement charges will be borne by M.C.G.M. in which case the decision of Ch. Engineer (M&E) shall be final.

The contractor shall arrange to direct the maintenance personnel to attend the Lifts immediately after receipt of break down call from the Municipal Engineer or authorised representative of the user department. The contractors shall give priority in their service, repair and manufacturing facilities to restore the equipments to normal service. In no case, the breakdown shall be kept unattended for more than two hours.

TECHNICAL SPECIFICATIONS M&E

The contractors shall attend to any number of breakdown calls between 6.00 A.M. to 10.00 P.M. on all days including Sundays and Holidays and in case of Emergency during night hours under unavoidable circumstance.

The contractor shall arrange to repair the Lift installation expeditiously without causing any inconvenience to the user department, failing which the repairs shall be got done at risk and cost of the contractors. However, in case of any major breakdown the contractor shall consult the Engineer concerned to carry out the repairs, which shall be completed within a day.

P.V.C. flooring shall be replaced once in two years. The selection of the Lifts for above works will be made by M.C.G.M. authorities.

The contractors shall inspect the Lift with Engineer concerned along with the Inspector of Lifts of P.W.D. and see that license is renewed with all compliance of P.W.D. requirement whenever called for.

The contractors shall have to carryout the work of repairs, maintenance and replacement of parts in good workmanship manner as per standard practice & Rules & Regulations of Lift Rules enforce.

The contractor shall maintain record of all the repair, servicing and maintenance works carried out and shall submit the necessary log- cards duly signed and stamped by Municipal Engineer or authorized person of user department to the office of Executive Engineer Mechanical (Electrical Installation) Maintenance at Municipal workshop at the end of each quarter.

The contractor will furnish the program of servicing and maintenance of Lifts for the whole year with date and timing etc. immediately on receipt of work order to the user department with a copy to Executive Engineer Mechanical (Electrical Installation) Maintenance at Municipal workshop within a week. Any changes in the above scheduled program shall be informed in Advance.

The contractors shall have to carry out any other work which is not included in the above terms and conditions under the instructions from Municipal Engineer of Executive Engineer Mechanical (Electrical Installation) Maintenance at Municipal workshop / Office with due approval of rates etc. for the satisfactory working of Lifts.

Before quoting the rates the Tenderer shall inspect the Lift installations. No extra claim whatsoever will be entertained later on during the contract period.

The contractor will replace all the parts (including indication lamps switches wire, cables, emergency lights batteries etc.) whenever found necessary due to normal wear and tear at their cost. Further, though the costs of replacement of the following items are not charged extra as the replacement of the same is covered under comprehensive maintenance contract for the normal working of Lifts with usual wear and tear, the contractor shall specifically quote the rates for the following which may become necessary in unusual circumstances:-

i)Replacement of Ropes

TECHNICAL SPECIFICATIONS M&E

- ii) Repairs to collapsible gates of car and landings.
- iii) Car enclosure (removable panels) door panels, hung ceiling, light diffuser, handrails, frames, sills etc.
- iv) Automatic Rescue Device.
- v) Audio Video overload warning indicator.
- vi) Infra-red Light Curtain.
- vii) Repairs to cabin fans.
- viii) Rewinding of motors.
- ix) Any other items.

The above rates will be applicable when repairs and replacement becomes necessary due to accidents, leakage / seepage of water or such reasons which are beyond the control of contractor. The Engineer of contract will decide the responsibility in such cases whose decision will be final.

The complete safety of human Life and the machinery and other parts of the lifts while carrying out the service and maintenance of the Lift will be the responsibility of the contractor. Any damages caused to the municipal property will be recovered from the bills.

The contract is terminable by either party, giving one calendar month's Notice in writing to his intention to discontinue it.

In case of disputes Municipal Commissioner's decision will be final and binding to both parties.

The Tenderer/ Quotationer shall specifically state their past experience in maintaining such lifts and also furnish the detailed List of Lifts maintained by them.

Attend the complaints free of cost whenever called by Corporation.

Whenever found necessary, the Contractor shall replace the spares and other parts of all the equipment's integrated to the lift operation, safety and statutory requirement free of cost.

The contractor shall check the performance of the lift after servicing by noting various operating parameters such as temperature control, load, setting etc.

The contractor shall invariably clean the premises of lift car top, lift pit and lift shaft, after carrying out the servicing work.

The contractor shall submit a preventive maintenance schedule for each lift and get it approved from the user dept.

The contractor shall submit the copies of service reports (duly signed by the user dept.) to E.E. Mech.(E.I.) Maint. every month.

The contractor shall have setup to receive & attend the complaints 24 hours a day. The break-down complaint shall be attended within 2 hours from intimation.

The contractor / firm has to arrange a technically qualified liaisoning officer in respect of day to day servicing and maintenance of lifts, who will keep regular contact with central office of

TECHNICAL SPECIFICATIONS M&E

Ex. Engr. Mech.(EI) Maint. and attend to the defects informed to him immediately. He shall give feedback to MCGM after complying with the rectification / repairs.

The contractor shall arrange for annual inspection of lifts by the lift inspector, PWD Govt. of Maharashtra during guarantee period and CSMC period. The inspection charges for the same shall be borne by contractors.

PENALTY TERM

Every breakdown or preventive maintenance call shall be backed by inspection report by the contractor.

Failure to attend the call shall attract penalty of Rs. 500/- for 1st incidence, which shall be doubled for subsequent failure. The maximum penalty shall be Rs. 2000/-

Due to non-availability of spares if the lifts remain un repaired for more than a week, prorate service charges for the month shall be deducted from the quarterly bill.

TERMS OF PAYMENT FOR COMPREHENSIVE SERVICE MAINTENANCE CONTRACT

The Quarterly payment of the Contract price will be paid within 30 days from the date of satisfactory completion of service and submission of bill. This contract is terminable by MCGM if the services rendered are unsatisfactory.

In case of dispute the Municipal Commissioner's decision will be final and binding on both the parties.

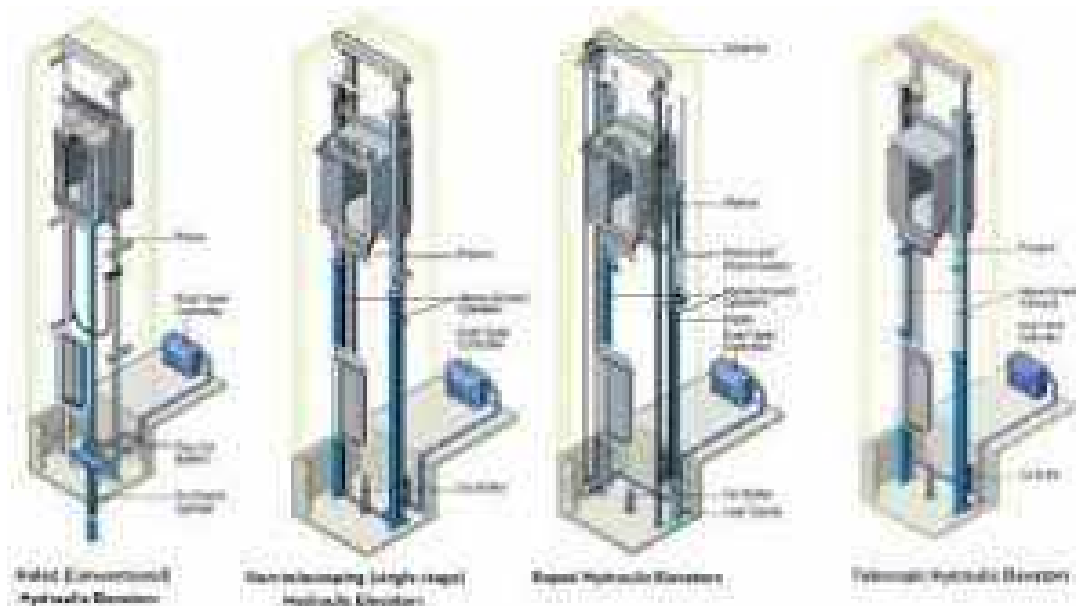

TECHNICAL SPECIFICATIONS M&E

SP-ME-TS-68 TECHNICAL SPECIFICATIONS (FOR Medical Gas pipeline and Modular Operation Theatre)

MEDICAL GAS PIPELINE SYSTEM:-

Medical Gas Pipeline System (MGPS) is intended to be a safe, convenient and cost-effective alternative to the use of “portable” cylinders, portable compressors and portable suction units, providing gas or vacuum for clinical needs with associated problems of portage, noise and space wastage. It delivers medical gases, medical air and other gases from the source of supply to the appropriate terminal unit by means of a pipeline distribution system.

The Quality of Gas delivered by MGPS has to be as per various Pharmacopoeia requirements.

The provision, installation, operation and maintenance of this MGPS Installation shall be governed by any one of the listed standards and guidelines: HTM02-01/ISO7396-1,2:2007/DIN/NFPA-99.

The system comprises of:

1. Oxygen manifold with automatic control panel and emergency manifold.
2. Nitrous oxide manifold with automatic control panel and emergency manifold.
3. Vacuum (suction) supply system complete.
4. Air supply system(4bar&7bar)complete.
5. Distribution piping complete with accessories.
6. Area Valve Service System.
7. Area Alarm Systems.
8. Medical gas outlet points
9. Pipe Distribution system
10. Master alarm panel
11. AGSS/WAGD
12. Accessories
13. Bedhead panels

1. Copper Piping:

Medical Grade Copper Tube/Pipes including all type of accessories Like Tee, Elbow, coupler, reducer etc. complete.

The piped distribution system shall use copper pipes manufactured from phosphorous de-oxidized non-arsenical copper grade CW024A (Cu-DHP), manufactured to metric outside diameters and having mechanical properties in accordance with BS EN 13348:2008 in either R250 (half hard) or R290 (hard). Degreasing of pipe shall be such that there is less than 20 mg/m²(0.002mg/cm²) of hydrocarbons on the degreased surface when tested by the method specified Norms. Copper pipe must have reputed third party inspection certificate

TECHNICAL SPECIFICATIONS M&E

(Eg. Lloyd's or TUV or SGS).The pipes should be accompanied with manufacturers test certificate for the physical properties & chemical composition. Copper pipes joined by silver brazing method for copper to copper. Inert gas welding technique should be used by passing Nitrogen gas inside the copper pipes during silver brazing, in order to avoid carbon deposition inside the copper pipes. Copper pipes to be fixed with walls with suitable saddles and supports. After erection, the pipes will be flushed and then pressure tested with dry nitrogen at a pressure equal to 1.5 times of the working pressure or 150psig, whichever is higher for a period of not less than 24 hours.

The pipeline should be adequately supported at sufficient intervals in accordance with Table below to prevent sagging or distortion. Supports for surface mounted pipe work should provide clearance to permit painting of the surface. Where it is essential for pipes to cross electric cables or conduit, they should be supported at intervals on either side of the crossing to prevent them from touching the cables or conduit. Supports should be of suitable material or suitably treated to minimize corrosion and prevent electrolytic reaction between pipes and supports.

Threaded joints in medical gas distribution piping shall be limited to connections to pressure/vacuum indicators, alarm devices, and source equipment.

The Pipe Sizes to be used are from among as under:

Outside Diameter (mm) X Thickness	Maximum interval between supports (Horizontal and Vertical).(m)
12 mmODX0.6 mm	1.5
15 mmODX0.7 mm	1.5
22mm.ODx0.9mm	2.0
28mm.ODx0.9mm	2.0
35mm.ODx1.2mm	2.5
42mm.ODx1.2mm	2.5
54mm.ODx1.2mm	2.5
76mm.ODx1.5mm	3.0
108mm.ODx1.5mm	3.0
Note: Consideration should be given to additional supports near LVAs,Elbows etc. where the Potential effects of inadvertently applied torque can result in severe pipeline distortion or fracture. Thickness shall be as per relevant standards	



Medical Grade Copper Tube/Pipes

2. Lockable Ball Valve

Single Port Ball Valve with Pipe line assembly (pre piped). Pre Piped Degreased Ball Valve with pipe extension. It should be full-port design. It should be blow-out proof stem. It should be lockable valve. The Valve shall be 3 piece ball-type design with a bronze body and chrome plated brass ball for sizes 1/2" to 4". Seats shall be Teflon (TFE) and seals Viton for 1/2" - 4" valves. A blow-out proof stem shall be used and the valve shall have a maximum pressure rating of 600 psi [4,137 kPa]. Valves shall be operated by a lever- type handle requiring only a quarter turn from a fully open position to a fully closed position. Valves shall be designed in such a manner that it can be "swung-out" during installation so as to prevent damage due to heat transfer during the brazing operation. Each valve assembly shall be washed and degreased for medical gas service. The valve shall be supplied in a sealed plastic bag to prevent contamination prior to installation. All valves shall be pneumatically tested for twice the working pressure and factory degreased for medical gas service.

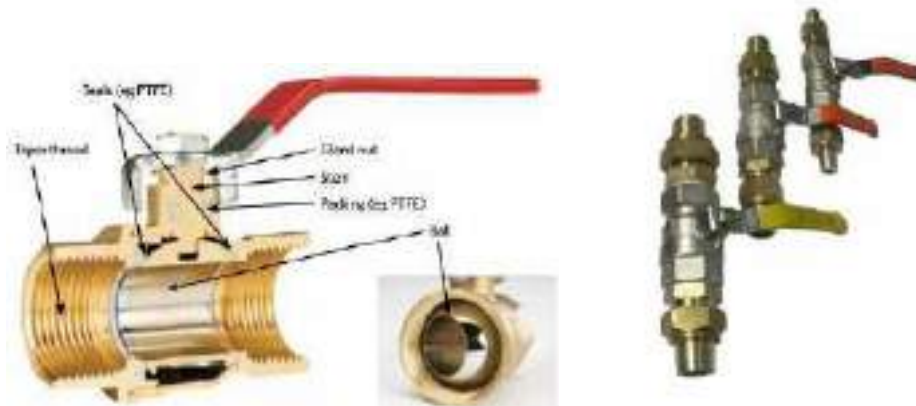

TECHNICAL SPECIFICATIONS M&E

3. Valve Box with Pressure Gauge

SITC of Gases Valve Box with pressure gauge only. It should have zone valve box shall consist of the following components: A steel valve box which can house two to seven shut-off ball valves as per requirement with tube extensions, an aluminium frame and a pull-out removable window. Gauges are included. The valve box shall be constructed of 18 gauge steel complete with a baked white enamel finish. Affixed to the opposite sides of the box will be two adjustable steel brackets for the purpose of mounting the box to the structural support. The steel brackets shall accommodate various finished wall thicknesses between 3/8" (9.5 mm) and 1-3/16" (30 mm) and shall be field adjustable. The removable front shall consist of a window with a pull-out ring pre-mounted to the center of the window. It should have access to the zone shut-off valves shall be by merely pulling the ring assembly to remove the window from the frame. The window can be reinstalled without the use of tools only after the valve handles have been returned to the open position. The window shall be marked to prohibit unauthorized persons from tampering with the valves with the following silk-screen caution: "MEDICAL GAS CONTROL VALVES CLOSE ONLY IN EMERGENCY"



4. Digital Area Alarm Panel

SITC of Digital Area Alarm with pressure sensor : Medical Gas LCD Alarm : The LCD alarm shall be microprocessor based with a screen and capable of monitoring medical gases. Each gas service shall be provided with a digital read-out comprising of 0-249 psi (0-1,717 kPa) for pressure and 0-30"Hg (-100-0 kPa) for vacuum. The digital read-out shall provide a constant indication of each gas being measured, indicating a green "NORMAL" and a red "HIGH" or "LOW" alarm condition. If an alarm occurs, the green indicator will change to red and a continuous audible alarm will sound. Pushing the (mute button/push to test button) will cancel the audible alarm, but the unit will remain in the alarm condition until the problem is

TECHNICAL SPECIFICATIONS M&E

rectified. The default set-points shall be +/- 20% variation from normal condition. In the calibration mode, High/Low set points shall be adjustable by Setup button and selecting set points with up and down buttons. To view the set points, press and hold the mute button for twenty (20) seconds. LCD alarm on a computer screen via the facility's ethernet or internet. In addition, an exact image of the alarm can be displayed on a mobile device on additional cost. The LCD Alarm will update its status every second. It should have self diagnostic and error message display for ease of maintenance.



5. Medical Gas Outlets

SITC of Medical Gas Terminal Units (Gas Outlets) : It shall be duly CE marked/UL listed. Terminal units shall have gas indexing geometry. Gas specific components comprising the terminal unit second fix shall be manufactured from die-cast zinc alloy or similar hard wearing metal. Plastic components are not acceptable. Terminal units socket castings shall be permanently coated with a low friction fluoropolymer for maximum reliability and service life. The terminal unit socket die-casting shall incorporate a gas indexing pin to overcome the risk of loosening due to rough handling or abuse. The second fix socket shall incorporate a shear- plane to safeguard the first fix and pipeline in the event of accidental damage or bed jacking. Gas specific components shall incorporate the gas identity marking permanently stamped or cast into the component surface. The first fix shall be all metal construction, with a brass base block and copper stub pipe. The first fix shall incorporate an integral check valve to enable servicing of the second fix and valve seals without isolation of the gas supply. Probe roller pins shall be manufactured from stainless steel. Wall mounted terminal units shall be provided with white ABS mounting box with matching fascia. The mounting box shall have smooth rounded corners to avoid the possibility of injury. A bezel shall be available to cover the plaster edge, provide a neat and easily to clean finish.

Outlet shall be equipped with a primary and secondary check valve and the secondary check valve shall be rated at minimum pressure of 200 PSI. In the event the primary check valve is

TECHNICAL SPECIFICATIONS M&E

removed for maintenance there should not be any leakage (on-line maintenance should be possible w/o disrupting the functioning of other outlets). Outlet bodies shall be gas specific by indexing each gas service to a gas specific pin indexing arrangement on the respective identification module. There should be a push button release mechanism for disconnecting apparatus accessible to outlets.



Allied Accessories :-

- 1) **SITC of Stainless Steel Ventilator Probe for Oxygen.**
- 2) **SITC of Stainless Steel Ventilator Probe for Medical Air/ Surgical Air.**
- 3) **SITC of Adaptor for connecting with oxygen flow meter**
- 4) **SITC of Adaptor for connecting with N2O**
- 5) **SITC of adapter for connecting with vacuum regulator**



6. Oxygen Flow meter

SITC of Oxygen Flow Meter 0-15lpm/70 lpm : It should be duly CE marked/ UL listed. Pressure compensated to prevent back pressure build up on flow indicator. It should have

TECHNICAL SPECIFICATIONS M&E

cartridge knob, extremely reliable, easy-to-clean and ensuring an optimized adjustment. Perfect tightness of the knob thanks to its polyamide seat. The knob shall be tested under pressurized working conditions during more than 10,000 cycles without showing any leakage after closing. Expanded scale providing higher reading accuracy. Durable polycarbonate flow tube with cover. The inopportune unscrewing of the monoblock scale cover is not possible. Body made of nickel-plated brass, very strong. Flowmeter should be MRI compatible. Flow meter should be placed in the vertical position and It should be light weight.

7.SITC of Humidifier Bottle : Polypropylene or Polysulphone 250cc Humidifier bottle should be unbreakable, reusable to disinfectants and complementsbe unbreakable, reusable to disinfectants and complements



8.Vacuum Regulator

SITC of Vacuum Regulator Unit : It should be duly CE marked/ UL listed. It should be continuous vacuum regulator, compact, strong and ergonomic device. It should have manual adjustment of the vacuum gauge for a better visibility. Vacuum gauge should be protected by a plastic housing. It should have on/off switch-button providing a quick restoration of the pre-adjusted vacuum level. It should have central regulation knob with a free rotation at the end of the course (impossible blocking). It should have quick adjustment turns that are enough to reach the maximum vacuum level. It should have vacuum levels : 0-1000m/bar. It should have a device with a metal outlet tubing nipple integrated in the body of the regulator for a better safety, emergency suction can even be processed. It should be supplied with a 1000ml safety jar equipped with a mechanical anti-over flow safety valve and single use antibacterial plastic filter upfront. The safety jar should be made of polycarbonate, autoclavable up to 134degree C and unbreakable. The safety jar should be fixed by an easy-click rotation. The safety jar should be able to rotate to avoid any pinch of the tubing. It should have a unit serial number laser engraved on the body of each vacuum regulator ensuring its identifications and traceability. It should be light weight. It should have vacuum levels: 0-760mm of Hg and vacuum gauge fitted with a protective bumper device. It should have on/off knob allowing for the quick restoration of are adjusted vacuum level.

TECHNICAL SPECIFICATIONS M&E

Ward vacuum Unit shall be wall mounted and shall consist of following:

- Suction Controller/Regulator
- Collection bottle 1000ml with mounting arrangement
- Suction Regulator: Suction regulator should be supplied with a safety jar, including an antibacterial filter and an anti-overflow safety device. Should have wide membrane continuous suction controller.

Theatre Vacuum shall consist of Units:

- 1 no. Suction Regulator
- 2 nos. 4000 ml polysulfone/polycarbonate collection jar and both to be mounted on a trolley
- Suction Regulator: Suction regulator should be supplied with a safety jar, including an antibacterial filter and an anti-overflow safety device. Should have wide membrane continuous suction controller



SITC of Polysulphide Vacuum Collection Jar 1000ml with lid

TECHNICAL SPECIFICATIONS M&E



Supply of indigenous D type empty oxygen cylinder with cylinder valve and cap (46.7L water capacity) ISI Mark-



Supply of indigenous D type empty N2O cylinder with cylinder valve and cap (46.7L water capacity) ISI Mark



SITC of Medical Gas Rubber tubing color coded throughout their length. All hoses shall incorporate an anti- static inner core (For All Gases)

9. Oxygen Automatic Control Panel

SITC of Oxygen Digital Fully Automatic Control Panel of 2000lpm . The manifold control panel shall consist of two bank regulators used to reduce the cylinder pressure to the two line regulators which in turn controls the final line pressure. The manifold has an intermediate and line relief valve that is internally connected to a common vent port, terminating into a 1/2" FNPT pipe. It should be fully automatic type and shall switch from "Bank in Use" to "Reserve Bank" without fluctuation in the final line pressure. The control panel includes a line gauge, two bank gauges and incorporates six LED"s. Input power to the manifolds is 110 to 240 VAC, 50-60 Hz. It should have flow capacity 4,500 SCFH [2,000 L/min]. (Maximum tolerance allowed will be only 10%). Control panel shall switch from In Use header to Secondary header without fluctuation in delivery supply line pressure.



10. SITC of Manifold, Header Bars, Tail Pipes: Two Sided Cylinder Manifold bank :

Cylinder racks shall be designed to securely support cylinders of varying diameters using chains.

Manifold header racks shall be high-pressure rated >250bar with gas specific tailpipe connections. High pressure collecting pipes made up of annealed cupronickel copper pipes with integrated non-return valves for connection of gas cylinders on the left and right cylinder bank side each. The high- pressure collecting pipe should be modular in nature with box nut and connector allowing any extension and combinations required in future. Collecting pipes including brackets and fixing materials should be gas type labelled and must be fully degreased for applications intended for and certified to this effect. .

TECHNICAL SPECIFICATIONS M&E

There should be middle frame manufactured from powder coated steel with wall bracket, chain & holder to hold each of the cylinders on both sides of the manifold Cylinder header racks .

There should be high-pressure valve with sintered bronze filter with replaceable filter element for particles between the manifold & the control panel on both the sides to protect foreign particles entering the control panel and also to isolate each manifold without closing individual cylinders.

Every individual connection must be equipped with a non-return valve, which prevents a return flow or running dry. A main shut- off valve must allow separation of the entire side from the supply and the manifold can be depressurised via a bleed valve. All components must be high-pressure resistant and thus withstand the operating pressure of 20,000kPa (200bar).

The Emergency Standby Manifolds (ESM) shall be designed and certified for use at 300 bar and 60°C. The ESM shall provide a backup supply of medical gas from a high pressure cylinder bank via a suitable arrangement of pressure regulators, providing a constant downstream nominal pipeline gauge pressure of 400kPa. Emergency Standby Manifolds (ESM) comprise a pressure regulator, manifold header & rack, tailpipes, an isolation valve and a pressure relief valve.





SITC of Manifold, Header Bars, Tail Pipes: Liquid Oxygen (Cryogenic Dura Cylinders) Stainless Steel Manifold Supply System of 10+10 size : 10cylinder manifold bank as left side and 10cylinder manifold bank as right side



Aluminium Ambient Vaporiser Coil for Liquid O₂ to gas conversion for a flow of 200 Nm³/hr: Vaporizer Coil:

- Maximum operating Pressure: 20 kg/cm²
- Design Pressure: 22 kg/cm²
- Pneumatic test Pressure: Greater than 24 kg/cm²
- Inlet temperature: - 196 to +40°C.
- Duty cycle: Continuous duty
- Flow rate : 200 cubic metre/ hour.

TECHNICAL SPECIFICATIONS M&E

Safety: The vendor should ensure that all international safety norms and standards applicable as implemented and certified by the CCE.

Statutory Requirements: All statutory requirements of the Chief Controller of Explosives of India and SMPV rules need to be followed; besides all regulations and guidelines put forward by the Govt. of India from time to time should be followed.

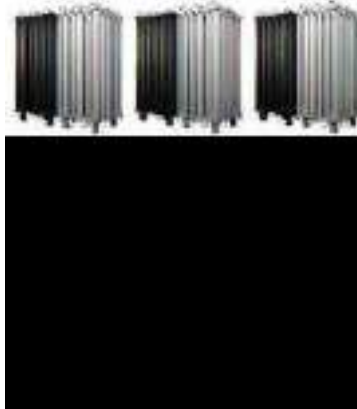

Liquid Oxygen Line Regulator



Liquid Oxygen Line Regulator

Vacuum Plants:-SITC of Vacuum Pump. : It should be oil lubricated vacuum pump, having required vacuum pump capacity with IEC Motor rating as per requirement. Vacuum pump shall comprise of air cooled, oil lubricated vacuum pumps suitable for both continuous and frequent start / stop operation at inlet vacuum vessels between 525mm Hg and 700 mm Hg. The ultimate vacuum of pump shall be 0.1 mbar with gas ballast valve closed. The Vacuum Pump should be air cooled and oil lubricated vacuum pumps designed for use in the field of high quality vacuum. Also Pump design should include a lubricant separation system integral to the pump exhaust box consisting internally installed lubricant and smoke eliminators through which the exhaust gas stream must pass. This system shall consist of bulk separation, lubricant mist elimination, smoke elimination, synthetic lubricant baffle, and shall be capable of removing 99.9 per cent of all lubricant and smoke particles from the exhaust gas stream. The unit should have extremely low vibration. (Maximum tolerance allowed will be only 10%).

TECHNICAL SPECIFICATIONS M&E

The vacuum pumps must have rugged design for extended, reliable and continuous service ensuring that there are no frequent oil changes. The unit should have extremely low vibration and should not require any special foundation for installation. On its own base frame the system should be plug and play ready for operation. The noise level of the pumps should not exceed 77dBA. The unit must be able to work at high temperatures ensuring continuous operation. There should be no requirement of water for cooling and the unit should be free from any frequent regular maintenances.

The control system should operate the vacuum pumps depending on the vessel vacuum level. The compact vacuum systems should be controlled by load stages, i.e. one of the vacuum pumps should control the base load. If peak load occur, then the second vacuum pump should be switched on. The third and fourth vacuum pump should act as a standby pump, whenever there are faults or maintenance work needs to be carried out. Whenever particular start-up /switch-off pressures are exceeded, then the corresponding vacuum pumps should switch themselves on or off.

The assignment of the vacuum pumps to the different load stages changes should occur automatically. In this way, the operating hours of the individual vacuum pumps should be evenly distributed. If a fault is recorded on one of the vacuum pumps, which has been selected by the control system, then the next available operational vacuum pump should be switched on automatically, as indicated by a malfunction message.



TECHNICAL SPECIFICATIONS M&E



Vacuum Filter:-

SITC of Vacuum Filter (Bacteria Filter)- Filter housing with drain flask.: The bacteria filter should be designed for critical application involving removal of dry and wet dust, particulars, oil aerosol and water droplets, high efficiency glass fiber, bacterial contamination from suction side of vacuum pump system. It should have efficiency of at least 99.995% when tested according to BS 3928:1969 or equivalent. The high efficiency medical grade filter element should have custom engineered filter media and deep pleat element technology provides minimal pressure loss and filtration efficiencies. It should have advanced filtration technology that captures particulates, bacteria and liquid aerosols reducing energy consumption and overall system costs. It should have corrosion protection Internal and external layer followed by a tough exterior polyester powder coating. It should have easily removable sterilisable drain flask and differential pressure monitor gauge. It should have push fit element design for quick and easy maintenance with unique push fit element design. It should have element end cap color black. It should have maximum temperature 60 degree

TECHNICAL SPECIFICATIONS M&E

centigrade (140 degree F). It should have pressure loss clean & dry = < 3kPa (30m/bar/0.44psig). It should have maximum working pressure 0.5barg(7psig). It should have manual drain valves and 250ml sterilisable glass drain flasks.(Maximum tolerance allowed will be only 10%).



TECHNICAL SPECIFICATIONS M&E

Vacuum Receiver(s) :-

Vacuum receiver(s) shall be supplied with relevant test certificates and have a total volume of at least 100% of the plant output in 1 minute in terms of free air aspired at normal working pressure. Each vacuum receiver shall be hot dip galvanised inside and out double coat primer and epoxy coated white RAL 9010. It shall be provided with supporting structures and allied accessories.



SITC of Electrical Control Panel for Vacuum pumps with time totalizer and phase preventer and cascading

TECHNICAL SPECIFICATIONS M&E



SITC of Electrical wiring inside plant room only for interconnection of vacuum pumps and air compressors (*User will provide 3 phase & single phase power supply with cable inside the gas manifold and plant room. User will provide DG back up and phase preventer + Isolation Transformer. User will provide all electrical fixtures like exhaust fan, light, power sockets inside gas manifold and plant room.

Medical Air Plants :Air Compressor:-

SITC of Oil Free Rotary Screw/Scroll Air Compressor : Oil free Rotary Screw/scroll air compressor. It should be 50Hz, 3 Phase, 440volts. 8 to 10.5Bar pressure, 116 to 155 Psig. The adequate flow capacity for each compressor unit having suitable IEC motor rating of Rotary Screw/scroll air cooled compressor. Compressors shall be oil free Rotary Screw/scroll compressors suitable for both continuous and frequent start/stop operation at a nominal outlet pressure of 800 to 1050kPa (8 to 10.5 bar). The air quality shall be 100% oil free, certified ISO8573-1. The compressor shall have a sound insulating enclosure. Air is drawn through air filter and should be compressed by the compressor element of each compressor module. Dependent on the model, the compressors have 3 or 4 electric motor driven compressor modules, enclosed in a sound insulating canopy. The compressors must have cooling air duct lined with sound insulation in dirt repellent material and integrated electrical control panel with minimum IP 54 protection grade. The compressors should be of super silenced types with the noise level not exceeding 75 dB.

The front door panel houses the Graphic controller and the emergency stop button. An electric cabinet with the electric components is installed behind the front panel. (Maximum tolerance allowed will be only 15%).

It shall include an additional pressure sensor and temperature sensor, required for transmitting additional alarm conditions. An additional analogue ammeter and inter locking isolator shall also be included.

TECHNICAL SPECIFICATIONS M&E

The compressors must be controlled by a central control panel. The programmable control unit must monitor the operational pressure and must switch the compressors as needed. The settings for the pressure switching levels should be settable from the front menu using the keys and display at the front panel.

The pressure reducing station should provide two outputs one at 4 bar for medical equipment and one at 7 bar for surgical equipment.

Compressor should be equipped with suction filter, suction regulator for no load start. Compressed Air system should have the following main features

- Air-cooled compressors for continuous duty application
- Highest output of compressed air per HP i.e. low power consumption
- Very low vibration resulting in low noise level



Air Dryer Unit:-

It should have air dryer desiccant type with 1/2" end BSP connection. It should have pre filter and post filter. It should be designed for ISO:7183- 1986 (E) standards or equivalent. It should have dryer quality class -ISO 8573-1 standards. It should be made of aluminium construction. It should have purge loss 15+/- 1%.

The dryer control system shall incorporate a Purge Saver Energy Management system that freezes the regeneration of the desiccant once adequate dew point is reached in the inactive tower. Only when the dew point level in the active tower deteriorates to an unacceptable level will the intelligent controller switch towers.

TECHNICAL SPECIFICATIONS M&E

This shall be achieved by including an additional dew point sensor and associated software in the dryer controller to effectively manage the system as well as providing on screen measurements of purge savings. An alarm condition shall trigger on the dryer control panel if the dew point exceeds a -46 degree C atmospheric set point.



Coarse coalescing filter:-

It should have flow-optimized design for advanced filter head design for optimized flow performance. It should have flexible installation Modular design and accessible fixings enable simple close coupling assembly. It should comply with air quality standard ISO 8573-1: 2010. It should have profiled bowl design and push fit elements ensure quick and for reliable maintenance. It should have corrosion protection Internal and external layer paint finish followed by a tough exterior polyester powder coating. It should have color coded element end caps of red color for easy and accurate grade identification. It should have particle retention of up to 99.999%, and significantly reduced pressure loss. It should have particle removal 1 micron. It should have maximum particle size class 2 micron as per ISO 8573-1: 2010 . It should have maximum oil content 3 micron ISO 8573-1: 2010. It should have maximum oil carryover at 68degree F (20degree centigrade) = 0.3 ppm (0.3mg/m3). It should have pressure loss clean & dry = 0.8psi (55m/bar). (Maximum tolerance allowed will be only 15%).



Fine coalescing filter:-

It should have flow- optimized design for advanced filter head design for optimized flow performance. It should have flexible installation Modular design and accessible fixings enable simple close coupling assembly. It should comply with air quality standard ISO 8573-1: 2010. It should have profiled bowl design and push fit elements ensure quick and for reliable maintenance. It should have corrosion protection Internal and external layer paint finish followed by a tough exterior polyester powder coating. It should have color coded element end caps of blue color for easy and accurate grade identification. It should have particle retention of up to 99.999%, and significantly reduced pressure loss. It should have particle removal 0.01 micron. It should have maximum particle size class 1 micron as per ISO 8573-1: 2010 . It should have maximum oil content 1 micron ISO 8573-1: 2010. It should have maximum oil carryover at 68degree F (20degree centigrade) = 0.01ppm (0.01mg/m3). (Maximum tolerance allowed will be only 15%).



Activated Carbon Filter:-

It should have flow-optimized design for advanced filter head design for optimized flow performance. It should have flexible installation Modular design and accessible fixings enable simple close coupling assembly. It should comply with air quality standard ISO 8573-1: 2010. It should have profiled bowl design and push fit elements ensure quick and for reliable maintenance. It should have corrosion protection Internal and external layer paint finish followed by a tough exterior polyester powder coating. It should have color coded element end caps of black color for easy and accurate grade identification. It should have particle retention of up to 99.999%, and significantly reduced pressure loss. It should have particle removal 0.01 micron. It should have maximum particle size class 1 micron as per ISO 8573-1: 2010. It should have maximum oil content 1 micron ISO 8573-1: 2010. It should have maximum oil carryover at 68degree F (20degree centigrade) = 0.003ppm (0.003mg/m3). (Maximum tolerance allowed will be only 15%).

Fine Dust Filter:-

It should have flow-optimized design for advanced filter head design for optimized flow performance. It should have flexible installation Modular design and accessible fixings enable simple close coupling assembly. It should comply with air quality standard ISO 8573-1: 2010. It should have profiled bowl design and push fit elements ensure quick and for reliable maintenance. It should have corrosion protection Internal and external layer paint finish followed by a tough exterior polyester powder coating. It should have color coded element blue color end caps for easy and accurate grade identification. It should have particle retention of up to 99.999%, and significantly reduced pressure loss. It should have particle removal 0.01 micron. (Maximum tolerance allowed will be only 15%).

TECHNICAL SPECIFICATIONS M&E

Air Receiver(s) :-

Air receiver(s) shall be supplied with relevant test certificates and have a total volume of at least 50% of the plant output in 1 minute in terms of free air aspired at normal working pressure. Each vacuum receiver shall be hot dip galvanised inside and out.

The Receivers Tank should be suitably designed with adequate capacity at an operating pressure of 10.5 bar. The receivers should be present in any configuration as desired to handle the designed load requirement. It shall be provided with supporting structures and allied accessories.

The vertical air receiver shall be vertically mounted and manufactured from heavy gauge fusion weld steel. The vertical air receiver shall be internally galvanised, double coat primer and epoxy coated white RAL 9010, fitted with automatic and manual drain valves and be protected by a pressure relief valve, fusible plug and include a pressure gauge.



Bed Head Panel : 1200mm

SITC of Double duct Bed Head Horizontal Wall Panel 1200 mm. Separate duct for gas outlet and separate duct for electricals. (made up from Aluminium powder coated profiles) with double duct. Separate duct for electrical sockets and separate duct for gas outlet points. Each bed head panel should be pre piped and pre wired. It should have pre wired 8 nos. electrical sockets in separate duct (4 nos. 5 A sockets and 4 nos. 15 A sockets). Gas outlet points 6 nos. pre piped to be fitted in the bed head panel. Gas outlet points cost not to be included in the bed head panel cost since it is separate line item. It should have provision for RJ45 connector and Nurse call system bedside switch with partition between LV and ELV system.

TECHNICAL SPECIFICATIONS M&E

IT should have Infusion pump mount pole with adapter for mounting at least two infusion pumps.

Bed Head Panel : 600mm

SITC of Double duct Bed Head Horizontal Wall Panel 600 mm. Separate duct for gas outlet and separate duct for electricals. (made up from Aluminium powder coated profiles) with double duct. Separate duct for electrical sockets and separate duct for gas outlet points. Each bed head panel should be pre piped and pre wired. It should have pre wired 4 nos. electrical sockets in separate duct (2 nos. 5 A sockets and 2 nos. 15 A sockets). Gas outlet points 2nos. pre piped to be fitted in the bed head panel. Gas outlet points cost not to be included in the bed head panel cost since it is separate line item. It should have provision for RJ45 connector and Nurse call system bedside switch with partition between LV and ELV system.



MODULAR OPERATION THEATER:-

Modular Operation Theatres (MOT) should be furnished on turnkey basis including Design, Engineering, fabrication, Installation, Integration, Testing & Commissioning of all items mentioned. It should be free-standing structure which allows easy repair, maintenance, integration & future expandability. **The Operation Theatre must be warranted for a period of three years from all defects.**

The MOT shall comprise of free standing wall substructure, SS wall panelling system, SS ceiling system, conductive flooring with necessary levelling, laminar air flow system, SS Exhaust air Cabinet with bottom fluff strainers, Auto/manual doors having double glass window in door leaf with necessary operators, illumination peripheral lights, Operating Theatre lights, HD Cameras, Control Panel, X-Ray viewing screen, Writing board, scrub station.

The Modular OT wall system shall have certification for hygiene, noise protection, radiation protection & fire protection. The bidders shall provide Test Reports/certification.

- a. The fire resistance for single panelled wall system including substructure work should confirm to Class A2, according to DIN 4102 (or equivalent BIS) required.
- b. Power operated windows, doors should comply ZH 1/494 directives and to be certified by manufacturer.
- c. Metal structure work should be in accordance to DIN 18360 (or equivalent BIS) to be certified by manufacturer/ installer.

Wall & Ceiling System :

1. Wall Sub-structure :

It should be made of galvanized steel having thickness not less than 1.5mm. This steel substructure will provide backing for prefabricated wall panels mounting and flush mounted equipment, display and control units, storage etc. The cavity between the inner and outer walls should be left with minimum obstructions for the possible addition of equipment at a later date and to enable services, pipes, conduits etc., to be run within the cavity.

2. Wall Panel:

The Operation Theatre wall panels system shall be fabricated in factory and shall be made from ANSI 304 Stainless Steel of thickness (1.2 or more) backed by class 2A fire rated material such as gypsum boards. Wall panels must be mounted onto the sub-structure in such a manner so as to enable easy installation. The gap between panels should be sealed with silicon gasket or suitable sealant to make it a continuous surface. Liquid silicone should not be used for sealing. Once fixed, they have to provide complete hygienic and hermetic sealing. The inner surface of OT should have coating with anti-bacterial and anti-mycotic properties.

TECHNICAL SPECIFICATIONS M&E

All wall-mounted equipment should be flush mounted. The wall panel design and construction should allow for the installation and support of all equipment and the provision of openings required for installations, without affecting rigidity and strength. There should not be any sharp edges and corners should be smoothed.

The individual wall panels should be made of single sheet without any joints. The individual wall panels should be attached to each other with suitable joining mechanism or an equivalent fastening system which will allow easy installation.

The prefabricated wall panels should be highly durable against mopping and steam cleaning. Colour scheme of OT should be co-ordinate with Architect. Resistance against common hospital cleaning and disinfection agents must be ensured.

In all the corners of the OTs, especially fabricated, one piece, angular SS wall panels shall be used both inside & outside the OTs. There shall not be any rubber seal / joint at any corner. Wall panels shall not have any horizontal joint, at any height from floor to false ceiling, except for installation modules i.e. control panel, X-ray, monitor, doors & cabinets etc.

Finished Floor to False Ceiling Height inside the OTs shall be minimum 3000 mm.

The wall system (panels and substructure) should be made of non-flammable material. No dangerous concentrations of gases should be produced in an event of fire. It should conform to Class A2, according to DIN 4102 (or equivalent BIS) required

3. Ceiling:

The ceiling system should also be made from Panels of ANSI 304 Stainless Steel of thickness (1.0mm or more) backed by class 2A fire rated material such as gypsum boards and be made of panels for easy installation and access for maintenance. It should be similarly prefabricated in the factory. It should have perfect sealing. The joints should be provided with a silicone sealing for a continuous optical closure and hermetical sealing. It should be stable and nonslip after adjustment.

The material of construction should be with a thickness of 1.0 mm or more. All ceiling panels should have folded edges.

The ceiling system (panels and substructure) should be made of non-flammable material. No dangerous concentrations of gases should be produced in an event of fire. It should conform to Class A2, according to DIN 4102 (or equivalent BIS) required

4. Antimicrobial Paint with Primer for OT:

All the sharp edges and corners should be smoothed to avoid bacteria contamination. The internal surfaces of the room walls and ceiling should be sprayed with anti- microbial paint, to a minimum dry film thickness of 300 microns. The coating should overlap the floor covering, ceiling system and doorframes by 25mm to provide a continuous sealed surface. The plastic coating should be non-reflective.

The biological efficiency of the anti-bacterial painting finish shall provide for minimum of 10 years ability to prevent mildew, bacteria and blight. The paint shall also be resistant to other pathogens which are prevalent in the hospital area and listed below: Acinetobacter sp,

TECHNICAL SPECIFICATIONS M&E

Aerobacteraerogenes, Bacillus subtilis (vediđer Bacillus sp), Enterobacteraerogenes, Escherichia Coli, Listeria Mozocytogenes, Pseudomonas Aeruginosa, Pseudomonas putida, Salmonella Typhimurium, Serratia Maercescens, Staphylococcus aureus. The Anti-Bacterial paint shall be resistant against abrasive and diluted acid and also alkali's which are in detergents etc.

5. Electro Static Dissipative/ Conductive Flooring :

a. Conductive Flooring:

Providing and fixing 2mm thick, permanently static conductive, pressed homogeneous vinyl sheet flooring with carbon backing as necessary of total thickness 2.00 mm. The flooring shall include necessary copper backing for necessary grounding. The flooring shall be polyurethane reinforced, scratch resistant, fire resistant, chemical resistant, slip resistant, resistant to fungal and bacterial growth with necessary coving of 100 mm.height. All floor joints shall be welded with compliant welding rods with adequate coving and a (skirting) level of 100mm shall be achieved on the wall.

b. Self-Levelling Subfloor: The entire floor shall be covered with self-levelling compound (of Make Ardex, Sika or equivalent) so as to achieve a levelled surface that will facilitate laying of the conductive flooring within necessary tolerances.

6. Recess mounted digital image viewing station designed for use in OT:

The device can operate in an independent mode by accessing radiological images from either USB storage device, or an optical disk; or in conjunction with PACS, RIS, HIS of Radiology department. Monitor of screen size 40 inches with anti-glare glass, and calibrated for viewing DICOM images. Unit equipped with easy to disinfect medical grade keyboard, touch pad, and optional USB mouse. Minimum requirements for integrated hardware – Intel i7 processor, 4GB RAM, 500GB HD, professional graphic card, and Windows7 Pro operating system.

7. Surgeon Control Touch screen panel :

The surgeon Control panel should be able to incorporate all the services within the operating theatre. The panel shall be touch screen type for premium Ots and membrane type for other OT's and shall be mounted on the theatre wall.

The panel shall be able to control the following services:

- Digital type Time day clock with high brightness characters
- Digital type Time Elapsed day clock with high brightness characters
- General Lighting Control System (on/off/endo)
- Control for Operating Theatre Lights with intensity, on/ off function
- Control for laminar flow (on/ off/ intensity setting)
- Control for OT table
- Operating Theatre temperature indicator
- Operating Theatre humidity indicator

- Medical gases with High and Low gas pressure indicator for each gas service present in the operating theatre and will have an audible buzzer with mute facility.
- Hands free Telephone system with memory
- HEPA filter status.
- Control for temperature and AGSS
- Music Control
- The touch panel should be upgradable type

8. Ceiling Air Management System:

The Ceiling Air Management System shall comprise of the following:

a. Laminar Air Flow H14 HEPA System :

The ceiling filtration system should be designed to ensure unidirectional distribution of sterile air with differential flow velocities decreasing from centre to perimeter of the surgical theatre to ensure the cleanliness of all the area covered by the air flow. The ceiling system should be equipped with HEPA filters with different performances according to their position in the ceiling to achieve different flow velocities. The complete filtration ceiling system should be factory assembled its holding structure, Filter frames and top plenum should be made of ANSI 304 stainless steel. Filtration ceiling system should have HEPA filters, according to EN 1822.

The filtration ceiling system should have flow equalizer to achieve uniform & constant air distribution over the whole surface it should also have connection for surgical lamp to be fitted in place of any filter.

The HEPA filters should have dust spot efficiency of 99.997% for 0.3 micron particles. Number of air changes should be such that Clean room classification can be maintained at Class 100, as per ISO 14644 System shall have CE mark as per MDD 93/42/EEC. Air extraction modules of the laminar flow system having two openings each, should be placed at four corners of the OT. The material of construction of the front cladding panel should be same as that of wall panels, and for riser duct may be same as that of air ducting inside OT. The extraction module openings should have suitable grills with fine washable filter, for easy cleaning and prevent residue build-up in the extraction chamber.

9. X-Ray/ CT scan LED Viewing Box:

Two plate X-ray/CT view screens should be provided with electrical safety for high & low voltage system. It should be designed to provide flicker free luminance for the film viewing purpose. It should be installed flushed with the wall for hygiene and ease of cleaning.

10. Pressure Relief Dampers Stainless Steel:

Pressure relief dampers should be provided in each room to prevent contamination of air from clean and dirty areas. Suitably sized air pressure relief damper should be strategically placed, enabling differential room pressure to be maintained and ensured when doors are opened. Counter-weight balancing system should be provided in the PRD to maintain positive pressure inside the operation room.

TECHNICAL SPECIFICATIONS M&E

Air pressure stabilizers should have unique capability of controlling differential pressure to close tolerance. The PRD should remain closed at pressure below the set pressure and should open fully at pressure only fractionally above the threshold pressure of 25 KPa. The body should be stainless steel grade 304 with stainless steel grill. Stainless Steel 304 Grade Plate should be used for body and with high grade SS 304 stainless steel for blades. Overall size of the P.R.D: 305 x 335mm or as per room size.

11. Storage Unit:

Size 2000mm x 1000mm x 230mm deep. The storage unit made from 1.5 mm of Stainless steel of SS304 grade. The doors shutter of the storage cabinet should house glass, and should be installed on the storage units with the help of fittings allowing an opening allowance of at least 160.

The storage unit should be divided in 2 equal parts and each part should have individual doors with stopper system. Each part should be provided with glass racks as per user department, and should be adjustable type.

12. Writing Board:

(List Board) Size: about 950mm x 650mm, flush mounted with wall panel

13. Hermetically Sealed Door & Frames:

The doors of the theatres should maintain sterility and the correct air pressure in the room. All doors into and out should be of the sliding, 100% hermetically sealing type. These doors should be durable and with ease of control, and versatility for clean environments. Each door should have vision panels of a minimum size of 300mm X 300 mm. In case of 2 doors, each leaf should have vision panels of a minimum size of 300mm X 300 mm.

The doors should meet the following specifications:

- The doorframe and the door panels should be made of high quality ANSI 304 Stainless Steel that can withstand high abrasion.
- The door should seal on all four edges in the closed position & should be surface installed type. Doors should be wired to the current IEE regulations & BS7971 standard.
- Motor should be DC 24V 70 W brush less DC Motor
- Noise level of movement should not be more than 60 decibel.
- Controller should be microprocessor based and be CE marked.
- Power efficiency should be .95 (in AC 100V full load).
- The track should be made up of single piece extruded aluminum.
- Environment temperature should be -20°C to +55° C.
- Starting time should be able to regulate from 0.5 second to 23 second & starting speed should be 600 mm per second.
- Electrical safety codes for high & low voltage system.
- Design should meet HTM 2020/2021 standards.

TECHNICAL SPECIFICATIONS M&E

- Nylon runner guides should be fixed to the door in such a way they do not obstruct trolley movement through the door.
- The door controller should be sensing overload condition and in overload in case the door will automatically stop & reverse the direction of travel.
- The controller should be capable of either being operated by elbow switches/foot switches, radar switch (touch less sensor).
- All doors should be able to be operated easily manually in the event of failure of the power supply or the automation unit
- Automation with 2 sensors - foot operation and hand sensors (magic switch).
- Opening, closing and stay-open times should be programmable.
- Electrical motor drive should offer various control types such as energy saving feature (partial opening adjustable for distance and time); automatic closing (full opening, adjustable for time); sluice function and permanent opening
- Lead protection on view window is necessary.

14. Medical Grade Copper Tube /Piping:

All Copper Pipes must be duly Medical Grade, seamless, fully degreased and half hard (designated to R 250). It should confirm and meet with the latest BS EN13348:2008 standard or equivalent. Chemical composition as per CU. DHP to 1190-1 and CW024A to EN 1412 or equivalent. Maximum total carbon content 20mg/m². Copper Pipes must have BS EN 13348:2008 and Kite mark or Lloyd or equivalent stamped on it.

15. Electrical wiring, Conduits with fixtures inside the OT:

Wiring with Low leakage current wires of FRLS wires as per requirements including providing and fixing of conduits and boxes, etc. to complete the work in all respect.

16. Air Exhaust shaft / box:

Exhaust Air Cabinets (4 nos. in each OT):

Especially designed Exhaust Air Cabinets (4 nos. in each OT) made of SS material, SS 304, same as used in wall system. Complete Cabinet should be a SS hollow box with a rectangular opening and Each of opening shall have fluff strainers (exhaust grills) for exhaust shall have openable access from the front for routine / periodic cleaning of accumulated bacteria (Fixed, non-openable exhaust grills shall not be used).

17. Peripheral Lights:

Peripheral lights should be integrated with the SS Ceiling/ Air Management System. The lights shall be have laminated safety glass cover with highly efficient reflectors to achieve glare free, flicker free, even lamination of 500 - 800 lux within the Operation Theatre. Body should be designed such as to achieve minimum IP 54 protection against dust and humidity. The Peripheral light should be LED Type, single colour with an addition facility for Endoscopy procedure.

18. Scrub Station:

The scrub unit shall be made of one piece ANSI 304 Stainless Steel material and shall be of antisplash design with minimum 1.0mm thickness. Each scrub station shall have four manual soap dispensers (two for each bay) and two taps Foot operated + (battery operated with individual/independent optical sensor. The taps shall have individual automatic mixer for hot & cold water through a temperature regulator/knob as a part of the tap.

19. Modular Operating Theatre Lights: Ceiling suspended Double Dome LED Surgical Light

The Operating Theatre lights should be hung rigidly from the ceiling of the modular operation theatre. Each dome should have a multi-lens matrix for a shadow free, homogenous, pure white, natural light field with sterilisable handle. The light should be shaped such as not to obstruct the laminar air flow.

The ceiling mounted Double Dome LED OT lights shall have following features:

- Illumination/ light head at 1m – 160,000 lux
- Bulb Type – LED
- Illumination adjustment - 30 – 100%
- Light Rotation – 360
- Color temperature – 4500 K fixed +/- 300 K
- Working range - 700 - 1400 mm
- Color rendering index > 90
- Power supply - 90 – 250 V AC
- Service Life > 40,000 hrs
- Power consumption - 60 - 110W
- It should be a flat, aerodynamic, open design suitable for laminar air flow ceilings.
- It should have a IR-free Illumination.
- Should have ENDO light function in OT light or Air Ceiling System.

20. Premium OT's - Ceiling suspended Triple Dome LED Surgical Light with HD Camera

The Operating Theatre lights should be hung rigidly from the ceiling of the modular operation theatre. Each dome should have a multi-lens matrix for a shadow free, homogenous, pure white, natural light field.

The ceiling mounted triple dome LED OT lights with HD Camera shall have following features:

- Illumination/ light head at 1m – 160,000 lux
- Bulb Type – LED

TECHNICAL SPECIFICATIONS M&E

- Illumination adjustment - 5 – 100% stepless
- Light Rotation – 360
- Color temperature – 4500 K +/- 300 K
- Working range - 700 - 1400 mm
- Color rendering index > 93
- Power supply - 90 – 250 V AC
- Service Life > 40,000 hrs
- Power consumption < 80 W-110W
- It should be a flat, aerodynamic, open design suitable for laminar air flow ceilings.
- It should have a IR-free Illumination.
- Should have ENDO light function in OT light or Air Ceiling System.

21. High Definition Camera :

The OT lights and camera system should have CE certification.

The Camera should have full HD video Output and following specification:

- CCD Sensor – 1/3” CMOS
- Zoom – 120 x motorized zoom (10 optical x 12 digital)
- Signal – HD 1080i
- Effective Pixels - Approx. 2 million
- Aperture – F1.8 – F2.1
- White Balance – Auto/ Manual
- Focus System – Yes (lockable)
- Antiflicker – Integrated
- Freeze – Integrated
- Contrast Enhancement – Auto
- Foot Control – Yes
- Location of camera – Integrated within OT light
- Monitor for HD Camera
- Picture Size > 19”
- LCD Panel – Active Matrix
- Resolution – 1920 x 1200

22.Operation Theatre Control Panel Membrane Type (CE-Mark):

The Product should be CE Certified make, manufactured as per standards in accordance with Medical Devices Directives 93/42/EEC. The Product should be factory tested, provision for pre dispatch Inspection necessary. The Operation Theatre Control Panel should be having following controls.

- Digital clock with battery
- Time Day Clock
- Time Elapse Day Clock
- Temperature measurement & display
- Humidity measurement & display
- OT light controls
- General light controls
- Hand free Telephone
- Medical Gases Alarm
- HEPA STATUS
- DIFFERENTIAL AIR PRESSURE GAUGE - DIGITAL OR ANALOG

The Surgeon control panel should meet electrical safety codes for high and low voltage system, wired to the current IEE regulations and The Operating room's surgeon control panel should be designed to cope with changing technology and equipment in operating environments. Control panel should be user friendly and with ease of operating & maintaining purpose.

The panel should be configured to incorporate all the services that operation room staff requires and control.

The fascia should be membrane made with superior quality material, UV Resistance with sterilization feature as per Operating Room requirement.

The Control Panel should have Isolated "NO" "NC" FOR HVAC and OT lights

The interior part of the panel can be accessed two ways front part inside the operation theatre or rear part outside the room. The access from inside the room through tillable doors. When access is done from outside, there will be rear door accessible from "dirty service" corridor if provision is there. Should have been factory assembled and tested should be Inspected at factory before delivery and type tested in accordance with MDD and CE Certified.

23. Ceiling Suspended Pendants:

a. Ceiling Suspended Pendants Anaesthesia :

- Dual Arm of about 800 mm + 800 mm

TECHNICAL SPECIFICATIONS M&E

- The 2 swivel arms, carrying the supply column, should have the maximum degree of rotary motion (3 x330degree)in the horizontal plane and should be able to hold a weight of upto 200kg
- The distribution column should be at least 1000mm in height.
- Minimum clearance from finished floor to bottom of pendant should be about 700 mm.
- Should have 2 platforms of about 500 x 450mm. The platforms should be adjustable along its vertical support and hence should be adaptable to the terminal units for which they are intended
- The following medical gas outlets should be provided on the back of the service head. It shall be CE marked.
 - O2 – 2 Nos
 - Nitrous Oxide – 1 Nos
 - Vacuum – 2 Nos
 - Medical Air – 1 No
 - AGSS -1 No
- All Gas Outlets should come fitted from the factory
- 12 electrical sockets should be provided on the service head (6 on each side), and should be compatible with the Indian plugs.
- Should have
 - Data Port – 2 No's
 - Video –Out/IN, Audio Out/In Socket
- The length of the drop tube from the extension arm should be suitable to the OT height
- The pendant should have a Pneumatic braking system or Electromagnetic type
- Main material used should be of high strength aluminum alloy or stainless steel, with a sealed design. Resistance against common hospital cleaning and disinfection agents must be ensured.
- It shall be CE marked.

b. Ceiling Suspended Pendants Surgeon :

- Dual Arm of about 800 mm + 800 mm
- The 2 swivel arms, carrying the supply column, should have the maximum degree of rotary motion (3 x330degree)in the horizontal plane and should be able to hold a weight of upto 150kg
- The distribution column should be at least 1000mm in height.

TECHNICAL SPECIFICATIONS M&E

- Minimum clearance from finished floor to bottom of pendant should be about 700 mm.
- Should have 2 platforms of about 500 x 450mm. The platforms should be adjustable along its vertical support and hence should be adaptable to the terminal units for which they are intended.
- The following medical gas outlets should be provided on the back of the service head. It shall be CE marked.
- O₂ – 2 Nos
- Vacuum – 2 Nos
- Compressed air supply – 1 No
- Medical Air – 1 No
- CO₂ - 1 No
- All Gas Outlets should come fitted from the factory
- 12 electrical sockets should be provided on the service head (6 on each side), and should be compatible with the Indian plugs.
- Should have
 - Data Port – 2 No's
 - Video –Out/IN, Audio Out/In Socket
- The length of the drop tube from the extension arm should be suitable to the OT height
- The pendant should have a Pneumatic braking system or Electromagnetic type
- Main material used should be of high strength aluminum alloy or stainless steel, with a sealed design, surface having antimicrobial and antifungal coating. Resistance against common hospital cleaning and disinfection agents must be ensured.
- It shall be CE marked.

c. Ceiling Suspended Percussionist Pendants :

- Slim and light weight unit with spring arm.
- The spring arm of length 1000mm and service head of 700mm with the support head should be able to hold a weight of 15kg.
- Platform on the support head of size 500 x 350mm, should be adjustable along its vertical support.
- The following medical gas outlets should be provided on the back of the service head. It shall be CE marked.
 - Oxygen – 2 Nos.
 - Medical Air – 1 No

TECHNICAL SPECIFICATIONS M&E

All Gas Outlets should come fitted from the factory

- 4 electrical sockets should be provided on the service head (6 on each side), and should be compatible with the Indian plugs.
- Data port – 1 No
- It shall be CE marked.

24. Audio System :

Audio system for Operating room to hear soothing music and radio channels. It should be able to play CDs, pen drive, hand held device.

Writing board should be made of ceramic having Magnetic properties and should be flushed to the wall of the operation room.

25. Degreasing:

All pipes, fittings and valves shall be degreased, steam cleaned internally, dried, shot blasted and blown through with medical quality air and individually capped at both ends after passing a visual internal inspection.

26. Fittings:

Fittings shall be wrought copper, brass or bronze conforming to BS: 864 parts 2 and suitable for a steam working pressure of 17 bar and especially made for brazed socket type of connections.

27. Area Valve Unit Module with single service valve box and area alarm fitted in module:

It should fully comply with HTM 2022, HTM02-01 and C11, or DIN standard or EN or NSPA or equivalent and must be duly CE marked with CE no. specified on it. It should be easy to operate and reliable.

28. AGSS hose kit with probe:

It should fully meet and comply with BS 5684, BS 6832 and HTM 2022, HTM02-01, C11 standards and must be duly CE marked or equivalent.